

FIG GARDEN ROTARY CLUB

BOARD OF DIRECTORS

Regular Meeting: 15 January 2003:

-Members Present:

*Directors:

Jamie Franklin
August Hioco
Steve Rontell
Richard Saroyan
David Stepp

*Foundation Treasurer:

Ron Fletcher

*Past President:

John T. Skewes

*Other(s) Present:

Steve Wilson, Director-
Elect

John Heberger, Past
President

*President:

Eric Fogderude

*President Elect:

Rod Coburn

*Treasurer:

Scott Bristol

*Secretary:

Doug Cords

The meeting was called to order by President Eric Fogderude at 7:04 a.m. in the new Boardroom of the newly relocated Stoughton Davidson Accountancy Corporation at 2520 West Shaw Lane, Suite 101, Fresno, California 93711.

*CONSENT ITEMS:

*Minutes Of The 18 December 2002 Regular Board Meeting		
*Attendance For Month Of December, 2002	=	73%
*Membership As Of 1 January 2003	=	104

It was MSC to approve the Consent Items as presented.

*TREASURER'S REPORT: (Scott Bristol)

Scott noted that officially posted were all current cash receipts and disbursements. Members' billings have been completed.

Full financial reports will be forthcoming at the next Board Meeting.

*SECRETARY'S REPORT:

The Secretary circulated for Board Members' review the most recent (November) District Attendance Report; Fig Garden Rotary was highlighted in the current District Newsletter for its "Holiday Gift Basket" program.

Rotary International's Semi-Annual Report And Billing was received and is in process. Secretary completes required information on members' professions and languages spoken/read, plus verifies and corrects the names and addresses as sent. This gives an opportunity to verify that all individual changes sent to Evanston have indeed been processed. Treasurer will remit to Evanston the sum of \$2,444. for our six-month billing.

The Board reviewed the Roster, a single-sheet with all contact information on members. Next month, Bill Griffith and David Bonnar, Blue Book Coordinators, will visit with the Board and at that time decisions shall be made regarding this document.

Longtime member Patty Hixson has returned from her health leave, and is welcomed back to the Club enthusiastically. She has worked diligently on projects.

Member and Board Director Wink Chase has accepted a position with his firm, Ryder Truck Rentals, in Southern California. He submitted his resignation from both the Club and the Board. In order to express the Club's sincere appreciation for his service and to facilitate his joining another Rotary Club, it was MSC to approve an "Excuse From Attendance Requirements" for Wink for the period 1 January to 30 June 2003. He will come to Friday meetings as possible. Wink will resign from the Club after he joins forces with sponsors in a Southern California Club.

Two new members were inducted into Fig Garden Rotary Club by President Eric on 10 January 2003:

*Mike Gerardi (Boy Scouts Of America)

*J. J. Roll (Kawah National Bank)

COG Co-Chair Daniel Bonyhadi was notified and is setting up a COG Social shortly for indoctrination.

Extensive discussion ensued regarding the continuing problem of current members introducing guests at Friday meetings as "prospective new members of Fig Garden Rotary," clearly against the spirit of our new member policy. Eric Fogderude, Rod Coburn and John Skewes will privately speak to those involved and a reminder shall be forthcoming from the podium at a meeting to please respect the membership proposal policy.

A thank you card from Dr. Teresa Patterson was circulated. Her resignation has been accepted and per earlier Board Action, when she wishes to return fees will be waived. She noted this will be something about which to look forward as she recovers her lost health. Board Members were encouraged to periodically call her and touch bases.

No New Member Proposals this month.

The Board charges the Secretary with tabulating and publishing in Avenues each member's Six-Month (and Year-End) attendance figures. Secretary works diligently with members who may be in trouble with the 30% attendance rule for Home Club and/or the 60% attendance rule for each six-months. In spite of these efforts, 12 members were kept in the Club with the generosity of Blood Center donations counting as make-ups. A confidential list of those names was circulated, with Directors asked to encourage those noted to get make-ups when they cannot attend our meetings.

Attendance records disclosed an exciting trend about late September - many more members than usual was delivering 100% attendance. A phone call program to encourage those who were showing 100% for the first time ensued. The result is that 55 Fig Garden Rotarians have earned 100% Attendance during the first half of President Eric's year - this is a new record for the Club, substantially surpassing our precious accomplishments. President Eric will encourage those members to repeat the performance for the final six months.

*PRESIDENT-ELECT'S REPORT: (Dr. Rod Coburn)

Plans are going well for the upcoming Auction. This week, e-mail and phone reminders have come to members from the Committee. Rod gratefully acknowledged past Auction Chairs; he shared that the amount of details that are required is amazing and he respectfully thanked his predecessors. Of particular note at this meeting for the current Auction is the work of Wes Segal for his great personal kickoff at the podium on 10 January and to Stan Skiba for his work on computer systems.

*PAST PRESIDENT'S REPORT: (John T. Skewes)

In the interest of time, John deferred his comments until a future meeting.

*PRESIDENT'S TIME: (Eric Fögderude)

It was MSC to bring onto the Board Director-Elect Matt Merzoian to fill the current vacancy for Vocational Service. David Stepp will copy a Board Booklet for Matt and he and President Eric will shortly meet to bring Matt up to speed on the position.

The President writes thank you letters to those individuals and organizations who have been a part of our Club's progress. Of late, a generous donation for Night On Fifth Avenue was received from Edmonds Jewelers.

Eric reviewed the format of the "Centennial Project" and will notice President-Elect Coburn and John Skewes of future meetings of the Area Club Presidents which calendar this agenda item.

There is a possibility that at California State University, Fresno home football games the local Rotary clubs will host a tailgate area; more discussion and information shall follow next month.

As previously noted, President Eric at year's end will recognize several members as "Most Active Rotarians," awards citing great service in the arenas of our Club's organization. He asked Board members to call with possible names and will do the same at a general Club meeting in the future.

*AVENUES OF SERVICE:

-Club Service: (August Hioco)

On February 2, Night On Fifth Avenue will take place. On February 14, the Club Meeting will be a special Valentine's Day luncheon, with spouses and others cordially invited. That evening will continue the celebration with an event at Roger Rocka's.

The month of March shall be focused entirely on the Club Auction.

Past President John Heberger gave an update on progress on the Night On Fifth Avenue event. To date, 94 persons have paid and/or sponsored participation. There is \$24,000 in merchandise available for bid. Current focus is on selling more tickets. Nancy Hinds Hospice will receive some of the proceeds.

-Community Service: (Richard Saroyan and Steve Rontell)

To date, there remain \$24,750. in uncommitted funds for Committee allocation. Eleven projects to date have been approved and/or funded.

Member Jeff Oliver brought to the Committee a request to participate in the Crime Stoppers Program, something the Club previously has supported. It was MSC to approve the sum of \$1,200. for a Gold Sponsorship. The Club is going to waive the customary plaque and tickets for two to a recognition dinner, totalling \$200. in costs to the program. That makes the entire sum of \$1,200. available for reward payments.

A letter was received from the Discovery Center requesting Club participation financially, probably in a large sum. This venue is a possible recipient of the all-area Centennial Project and thus a decision as to how/if Fig Garden Rotary Club will interact with the Discovery Center will be postponed pending decisions on the larger project. If Discovery Center is not the choice for the Centennial Project, the Club will research carefully the possibility of partnering with them.

-Vocational Service: (David Stepp)

The next venue' if the High School Scholarship Program. All schools have been contacted and initial mettings will take place in February.

-International Service: (Jamie Franklin)

Jamie reported on the follow-up of the recent Wheelchair Program. To date 95 chairs have been committed by members. An extensive discussion ensued as to how to best bill members who have not submitted checks. John Heberger will bill members.

It was MSC to release \$18,500 of Foundation Funds and authorize the International Committee to work with the Wheelchair Foundation on the country which shall receive the gifts, with further promotions to members to donate to the program.

President Eric will note from the podium the continued opportunity and shall place a notice in Avenues. When the final details of the donation are ready, a final promotion shall take place to solicit more gifts. Foundation Treasurer Ron Fletcher shall provide the check to Jamie promptly.

*OLD BUSINESS: No Old Business This Meeting.

*NEW BUSINESS:

Director Steve Rontell noted the tragic loss last week to North Fresno Rotarian Skip Carlstrom whose son was killed. Skip was a Past President of Playland/Storyland and has developed strong friendships with many Fig Garden Rotarians. In lieu of setting a Club precedent, a Board member will contribute to the memorial fund in the Club's name.

*ADJOURNMENT: The Meeting Was Adjourned at 8:24 a.m.

*NEXT MEETING: 19 February 2003.

Respectfully Submitted By Doug Cords, Ph.D., Club Secretary.

FIG GARDEN ROTARY CLUB

FOUNDATION
BOARD OF DIRECTORS

Regular Meeting: 15 January 2003:

-Members Present:

*Directors:

Jamie Franklin
August Hioco
Steve Rontell
Richard Saroyan
David Stepp

*Foundation Treasurer:

Ron Fletcher

*Past President:

John T. Skewes

*Other(s) Present:

Steve Wilson, Director-Elect

John Heberg, Past President

*President:

Eric Fogderude

*President Elect:

Rod Coburn

*Treasurer:

Scott Bristol

*Secretary:

Doug Cords

The meeting was called to concurrent order by President Eric Fogderude with the Regular Meeting of the Fig Garden Rotary Club, in the new Boardroom of the relocated Stoughton Davidson Accountancy Corporation at 2520 West Shaw Lane, Suite 101, Fresno, California 93711 at 7:04 a.m.

*TREASURER'S REPORT: (Ron Fletcher)

Ron reviewed the current accounts, as follows:

*Unrestricted Funds:	\$105,724.00
*Permanent Funds *	129,564.00 (*Board-Designated)
*Totals:	<u>\$235,288.00</u>

All outgoing checks will be processed through the Washington Mutual accounts and receipts are being received for each expenditure. Ron reviewed the December, 2002 expenses. Encumbered, but not paid out costs are:

*Bullard Interact	*Make A Wish Foundation
*Play It Safe Foundation	*Holiday Gift Baskets

Ron reviewed the printouts of various UBS/Paine Webber accounts. He will reimburse Club Treasurer Scott Bristol for an advance on the Holiday Gift Basket account, done because of time constraints.

The Investment Committee will meet next on February 11, 2003 at 4:00 p.m.

It was MSC to approve the Treasurer's Report as presented.

-ADJOURNMENT: Concurrent With Regular Board Meeting, Adjourned At 8:24 a.m.

-NEXT MEETING: 19 February 2003.

Respectfully Submitted By Doug Cords, Ph.D., Foundation Secretary.

Fig Garden Rotary Endowment Account

Asset Allocation

US Large Co. Equity	\$ 21,613	16.72%
US Med/Sm Co. Equity	\$ 21,454	16.59%
Balanced	\$ -	0.00%
Int'l Equity	\$ 13,778	10.66%
Int'l Fixed Income	\$ -	0.00%
US Fixed Income	\$ 51,000	39.44%
Cash/Money Market	\$ 21,450	16.59%
	\$ 129,295	100.00%

Account Allocation

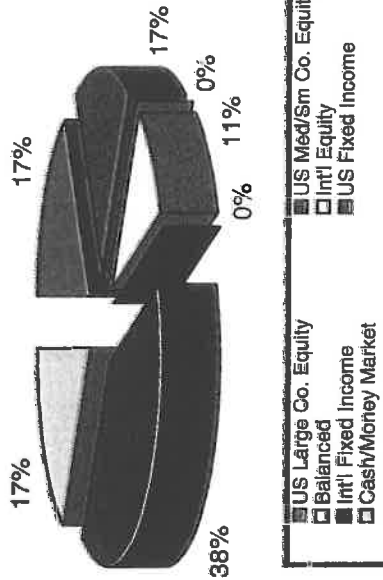

* face Value at maturity.

Investment Holdings

as of 12/31/02

Current
Values

<u>US Large Co. Equity:</u>		
Income Fund of America	\$	10,418
Pimco Value Fund	\$	11,196
<u>US Med/Sm Co. Equity:</u>		
Liberty Acorn Fund	\$	10,416
Pimco Small Cap Value	\$	11,038
<u>Balanced:</u>		
<u>Int'l Equity</u>		
Templeton Foreign	\$	13,778
<u>US & Int'l Fixed Income:</u>		
CD Independent Bank 2% due 10/23/03	\$	13,000 *
CD Discover Bank 2.5% due 11/08/04	\$	12,000 *
CD Key Bank & Trust 3.1% due 11/08/05	\$	13,000 *
CD Pan American Bank 3.65% due 10/30/06	\$	13,000 *
<u>Cash/Money Market:</u>		
Money Market	\$	21,450
TOTAL PORTFOLIO		\$ 129,295



UBS PAINWEBBER INC.
 FIG GARDEN FINANCIAL CENTER
 5200 NO. PALM, SUITE 101
 FRESNO, CA 93704-7669

Your Financial Advisor
 SAHOTA, GURKIRPAL (PAUL)
 559-226-2800/800-423-8797

**UBS PaineWebber InsightOneSM
 Business Services Account BSA[®]**

PZ1A004984-X26

Statement Period: December 2002
 Account Number: FE 31031 20

This month at a glance

Value on November 29	\$	130,841.14
Value on December 31	\$	129,564.08
Sweep balance in 12/31 value	\$	21,449.98

Earnings summary

Earnings are for the current calendar year. All prior year entries are summarized separately. This information should not be used for tax purposes. Refer to the disclosure on the back of the first page.

	Current period	Year-to-date
UBS PaineWebber Money fund dividends	\$ 19.19	\$ 105.80
Other dividends	912.92	912.92
Interest	1.69	8.36
Plus non-municipal accrued interest received	.00	.97
Less non-municipal accrued interest paid	.00	-17.06
Other	15.27	15.27
Net security earnings	\$ 949.07	\$ 1,026.26
Return of capital/principal	\$ 2.41	\$ 182.17

Investment objectives

The following return objective and risk profile describe overall goals for this account. For each account held, you choose one return objective and primary and, if applicable, secondary risk profile. A full description of the alternatives is included on the back of the first page. If you have questions regarding these objectives or wish to change them, please contact your Financial Advisor or Branch Manager at your branch office to update your account objectives.

Return objective: Current income & capital appreciation
Risk profile: Primary: Moderate Secondary: Conservative

FIG GARDEN ROTARY FOUNDATION
 ENDOWMENT FUND
 5180 N PALM AVE SUITE 101
 FRESNO CA 93704-2203

Bulletin Board

ATTENTION BOND INVESTORS: EARLY 2003 WILL SEE VERY HIGH LEVELS OF TAXABLE AND MUNICIPAL BOND REDEMPTIONS. SPEAK WITH YOUR FINANCIAL ADVISOR ABOUT YOUR HOLDINGS.

RESOURCELINE 1-800-BSA-0140: ACCOUNT #: 095031031
 VISIT OUR WEB SITE AT WWW.JBSPAINWEBBER.COM.

Asset summary

Refer to the disclosure on the back of the first page for information on assets excluded from this summary.

	% of portfolio	Value
Certificates of deposit	39.57	51,269.15
Money funds/sweep investments	16.56	21,449.98
Mutual funds	43.87	56,844.95
Net invested assets	100.00	\$ 129,564.08
Value on December 31		\$ 129,564.08

Account Number: FE 31031 20
 Your Financial Advisor
 SAHOTA,GURKIRPAL (PAUL)
 559-226-2800/800-423-8797

**UBS PaineWebber InsightOneSM
 Business Services Account BSA[®]**

PZ1A004995-X26

Statement Period: December 2002

Activity highlights

	Current period	Year-to-date
Deposits	\$.00	\$ 112,796.96
Program fees and related services	.00	-236.30
Securities transferred in (valued at time of transfer)	.00	14,474.71
Net change from activity listed above	\$.00	\$ 127,035.37

Portfolio summary

	Current period	Year-to-date
Opening value	\$ 130,841.14	\$.00
Net change from Activity Highlights	.00	127,035.37
Net security earnings	949.07	1,026.26
Change in value of investments	-2,226.13	1,502.45
Value on December 31	\$ 129,564.08	\$ 129,564.08

Asset portfolio

When available, prices, income and current values may be approximately and thus gains/losses may not be accurately reflected. Refer to the disclosure on the back of the first page. An asterisk (*) indicates a change in the original transaction data from the prior month or the display of new data input at your branch office. Gains/losses are not calculated for zero coupon investments. "Pending adjustment" or "P/A" indicates cost basis has not yet been allocated as a result of a spin-off or taxable exchange.

Certificates of deposit

Coupon CDs

Total face value at maturity	Description	Value	Est. annual income	Trade date	Face value purchased	Purchase price	Cost basis
13,000	CD INDEPENDENT BK EAST RATE 02.000% MATURES 10/23/03 INTEREST EARNED FROM 10/23/02 1ST INTEREST PAYMENT 10/23/03	12,916.93	260	10/31/02	13,000	99,799	12,973
12,000	CD DISCOVER BANK RATE 02.500% MATURES 11/08/04 INTEREST EARNED FROM 11/06/02 1ST INTEREST PAYMENT 05/08/03	12,043.08	300	10/31/02	12,000	100,000	12,000

Account Number: FE 31031 20
 Your Financial Advisor
 SAHOTA, GURKIRPAL (PAUL)
 559-226-2800/800-423-8797

**UBS PaineWebber InsightOneSM
 Business Services Account BSA[®]**

PZ1A004996-X26

Statement Period: December 2002

Coupon CDs - continued

Total face value at maturity	Description	Value	Est. annual income	Trade date	Face value purchased	Purchase price	Cost basis
13,000	CD KEY BANK AND TRUST RATE 03.100% MATURES 11/08/05	13,123.76	403	10/31/02	13,000	100,000	13,000
13,000	1ST INTEREST EARNED FROM 11/08/02						
	1ST INTEREST PAYMENT 05/08/03						
13,000	CD PAN AMERN BK FSB RATE 03.650% MATURES 10/30/06	13,185.38	475	10/31/02	13,000	99,468	12,930
	INTEREST EARNED FROM 10/30/02						
	1ST INTEREST PAYMENT 04/30/03						
51,000	Total	\$ 51,269.15	1,438				50,903

Money funds and other sweep investments

Description	Opening balance	Closing balance	Closing share price	Average yield	Dividend period	Days in period
RMA MONEY MKT. PORTFOLIO	20,498.50	21,449.98	1.00	1.06%	11/22 - 12/23	32
Total	\$ 20,498.50	\$ 21,449.98				

Mutual funds

Unrealized gain/loss indicates the cost basis versus the current value for each security lot from a tax reporting perspective and is the amount that would be realized should you sell the lot. Cost basis may need to be adjusted for return of capital payments. An "earnings" lot represents the aggregate cost basis of all dividends paid that were reinvested in the fund. If you have earnings lots, an additional calculation appears showing the overall change in value of your current position versus the money you invested in the fund. This "investment return" shows overall performance of your total investment including dividends reinvested in the fund and market appreciation or depreciation. The "investment return" figure does not include cash dividends not reinvested in the fund.

Total shares	Description	Price	Current value	Est. annual income	Trade date	Shares purchased	Purchase price	Cost basis	Unrealized Gain/loss
727	AMERICAN FUNDS INCOME FUND OF AMERICA CLASS F	14.330	10,417.91	555	10/31/02	656,000	13,910	9,124	276
1,658	FT TEMPLETON FOREIGN A	8.310	13,777.98	230	11/13/02	71,000	13,970	991	26
					10/31/02	1,537,000	8,290	12,741	31
679	LIBERTY ACORN FUND CLASS A	15.340	10,415.86		11/13/02	121,000	8,220	994	11
562	PIMCO NFJ SMALL CAP VALUE FUND CLASS A	19.640	11,037.68		10/31/02	612,000	14,890	9,112	276
					11/13/02	67,000	14,860	995	32
1,029	PIMCO PEA VALUE FUND CLASS A	10.880	11,195.52		11/04/02	510,000	19,630	10,011	5
					11/13/02	52,000	19,110	993	28
					10/31/02	936,000	10,680	9,996	187
					11/13/02	93,000	10,670	992	19
	Total	\$	56,844.95	785				55,949	891



Account Number: FE 31031 20
 Your Financial Advisor
 SAHOTA, GURKIRPAL (PAUL)
 559-226-2800/800-423-8797

**UBS PaineWebber InsightOneSM
 Business Services Account BSA[®]**

PZ1A004997-X26

Statement Period: December 2002

Monthly activity

Cash flow and security transactions

Refer to the disclosure on the back of the first page regarding the Price/Value presented for restricted securities.

Date	Activity	Description	Quantity/ Face value	Price / Value	Cash amount	Cash & Total Money fund/sweep balance
11/29		Cash, Money fund and other sweep investments balance			\$	20,498.50
12/13	ST CAP GAIN	PIMCO PEA VALUE FUND CLASS A			596.60	
12/13	DIVIDEND	SHORT TERM CAPITAL GAIN AS OF 12/12/02				
12/13	ST CAP GAIN	PIMCO NFJ SMALL CAP VALUE FUND CLASS A AS OF 12/12/02			118.64	
12/16	INTEREST	PIMCO NFJ SMALL CAP VALUE FUND CLASS A SHORT TERM CAPITAL GAIN AS OF 12/12/02			30.31	21,244.05
12/16	RETURN OF PRINCIPAL	FHLMC PL 170020 7.5000 DUE 06/01/08 FACTOR 0.019336600000 PAID ON 13000 AS OF 12/15/02			1.69	
12/17	DIVIDEND	FHLMC PL 170020 7.5000 DUE 06/01/08 FACTOR 0.019336600000 PAID ON 13000 AS OF 12/15/02			2.41	21,248.15
12/17	LT CAP GAIN	AMERICAN FUNDS INCOME FUND OF AMERICA CLASS F AS OF 12/16/02			125.92	
12/17	DIVIDEND	AMERICAN FUNDS INCOME FUND OF AMERICA CLASS F 20% RATE GAIN AS OF 12/16/02			15.27	
12/24	DIVIDEND	FT TEMPLETON FOREIGN A			41.45	21,430.79
12/31		RMA MONEY MKT. PORTFOLIO AS OF 12/23/02			19.19	21,449.98
		Closing cash, Money fund and other sweep investments balance			\$	21,449.98
		Total Money fund and other sweep investments balance			\$	21,449.98

Money funds and other sweep investments

The RMA Money Mkt. Portfolio is your primary sweep fund.

Date	Activity	Amount	Balance
11/29	Opening RMA Money Mkt. Portfolio	\$	20,498.50
12/16	BOUGHT	\$ 745.55	\$ 21,244.05
12/17	BOUGHT	4.10	21,248.15
12/18	BOUGHT	182.64	21,430.79
12/24	BOUGHT		19.19
12/31	Closing RMA Money Mkt. Portfolio	\$	\$ 21,449.98

UBS PAINWEBBER INC.
 FIG GARDEN FINANCIAL CENTER
 5200 NO. PALM, SUITE 101
 FRESNO, CA 93704-7669

Your Financial Advisor
 SAHOTA,GURKIRPAL (PAUL)
 559-226-2800/800-423-8797

**UBS PaineWebberSM
 Business Services Account BSA[®]**

PZ1A004999-X26

Statement Period: December 2002
 Account Number: FE 31093 20

This month at a glance

Value on November 29	\$	90,289.45
Value on December 31	\$	90,373.45
Sweep balance in 12/31 value	\$	90,373.45

Activity highlights

	Current period	Year-to-date
Deposits	\$.00	\$ 90,281.19
Net change from activity listed above	\$.00	\$ 90,281.19

Portfolio summary

	Current period	Year-to-date
Opening value	\$ 90,289.45	\$.00
Net change from Activity Highlights	.00	90,281.19
Net security earnings	84.00	92.26
Value on December 31	\$ 90,373.45	\$ 90,373.45

Earnings summary

Earnings are for the current calendar year. All prior year entries are summarized separately. This information should not be used for tax purposes. Refer to the disclosure on the back of the first page.

	Current period	Year-to-date
UBS PaineWebber Money fund dividends	\$ 84.00	\$ 92.26
Net security earnings	\$ 84.00	\$ 92.26

FIG GARDEN ROTARY FOUNDATION
 5190 N PALM AVE SUITE 101
 FRESNO CA 93704-2203

Bulletin Board

ATTENTION BOND INVESTORS: EARLY 2003 WILL SEE VERY HIGH LEVELS OF TAXABLE AND MUNICIPAL BOND REDEMPTIONS. SPEAK WITH YOUR FINANCIAL ADVISOR ABOUT YOUR HOLDINGS.
 RESOURCELINE 1-800-BSA-0140; ACCOUNT #: 095031093
 VISIT OUR WEB SITE AT WWW.UBSPAINWEBBER.COM.

Asset summary

Refer to the disclosure on the back of the first page for information on assets excluded from this summary.

	% of portfolio	Value
Money funds/sweep investments	100.00	90,373.45
Value on December 31	\$	90,373.45



Account Number: FE 31093 20
 Your Financial Advisor
 SAHOTA, GURKIRPAL (PAUL)
 559-226-2800/800-423-8797

**UBS PaineWebberSM
 Business Services Account BSA[®]**

Statement Period: December 2002

PZ1A006000-X26

Investment objectives

The following return objective and risk profile describe overall goals for this account. For each account held, you choose one return objective and primary and, if applicable, secondary risk profile. A full description of the alternatives is included on the back of the first page. If you have questions regarding these objectives or wish to change them, please contact your Financial Advisor or Branch Manager at your branch office to update your account objectives.

Return objective: Current income
Risk profile: Primary: Conservative Secondary: None Selected

Asset portfolio

When available, prices, income and current values may be approximately and thus gains/losses may not be accurately reflected. Refer to the disclosure on the back of the first page. An asterisk (*) indicates a change in the original transaction data from the prior month or the display of new data input at your branch office. Gains/losses are not calculated for zero coupon investments. "Pending adjustment" or "P/A" indicates cost basis has not yet been allocated as a result of a spin-off or taxable exchange.

Money funds and other sweep investments

Description	Opening balance	Closing balance	Closing share price	Average yield	Dividend period	Days in period
RMA MONEY MKT. PORTFOLIO	90,289.45	90,373.45	1.00	1.06%	11/22 - 12/23	32
Total	\$ 90,289.45	\$ 90,373.45				

Monthly activity

Cash flow and security transactions

Refer to the disclosure on the back of the first page regarding the Price/Value presented for restricted securities.

Date	Activity	Description	Quantity/ Face value	Price / Value	Cash amount	Cash & Total Money fund/sweep balance
11/29		Cash, Money fund and other sweep investments balance			\$	90,289.45
12/24	DIVIDEND	RMA MONEY MKT. PORTFOLIO AS OF 12/23/02		84.00	\$ 84.00	90,373.45
12/31		Closing cash, Money fund and other sweep investments balance			\$	90,373.45
		Total Money fund and other sweep investments balance			\$	90,373.45

Money funds and other sweep investments

The RMA Money Mkt. Portfolio is your primary sweep fund.

Date	Activity	Amount	Balance
11/29	Opening RMA Money Mkt. Portfolio	\$	90,289.45
12/24	BOUGHT AS OF 12/23/02	\$ 84.00	90,373.45
12/31	Closing RMA Money Mkt. Portfolio	\$	90,373.45

**UBS PaineWebber InsightOne™
Business Services Account BSA***

PZNL004723-716

Statement Period: October 2002

Account Number: FE 31021 20
Your Financial Advisor
SAHOTA GURKIRPAL (PAUL)
559-225-2800/800-423-8787

Mortgage-backed securities - continued

Total original face value	Description	Price	Quantity	Est. annual income	Trade date	Price value purchased	Purchase price	Adjusted cost basis	Unrealized Gain/Loss
16,000	PRUD HOME MTG SEC P/THR SER 04-21 CL A8	100.348	1,045.82	81		16,000			
	RATE 07.800% MATURES 05/25/24								
	MAY BE CALLABLE								
	CURRENT PAR VALUE 1.042								
	Total		\$ 1,334.22	101					

Monthly activity

Cash flow and security transactions

Refer to the disclosures on the back of the first page regarding the Price/Value presented for restricted securities.

Date	Activity	Description	Quantity/ Face value	Price/ Value	Cash amount	Cash & Total Money Fund balance
09/30		Cash and total Money fund balance forward				.00
10/30	DEPOSIT	LOCAL CHECK			20,347.98	20,347.98
10/16	RECEIVE	CREDIT CASH BALANCE*		55.8		
10/16	RECEIVE	AMERICAN FUNDS INVESTMENT COMPANY OF AMERICA CL A	573.591	13,098.47	36,469.66	36,469.66
10/16	RECEIVE	PHMS 04-21 A8 07.800% DUE 06 25 24	16,000.000	1,420.68		
10/16	RECEIVE	FACTOR 0.069716310401				
10/16	RECEIVE	FHLMG PL 170020 7.5000 DUE 06/01/08	13,000.000	287.38		
10/16	RECEIVE	FACTOR 0.022810400080				
10/17	DEPOSIT	NON-LOCAL CHECK			53,659.09	59,907.68
10/21	RECEIVE	CREDIT CASH BALANCE			14.37	112,696.76
10/25	DIVIDEND	RMA MONEY MKT. PORTFOLIO AS OF 10/24/02			25.30	112,711.32
10/29	FEE BILLED	INITIAL FEE Initial Deposit \$127,620			-256.30	112,730.42
		Billing Days 09/305 Annual Fee Percentage 0.80				
10/29	RECEIVE	CREDIT CASH BALANCE			80.89	125,991.59
10/29	SOLD	AMERICAN FUNDS INVESTMENT COMPANY OF AMERICA CL A FBOLD 22870713920	-573.594	26.380	13,410.63	125,991.59
10/31		Closing cash and total Money fund balances				\$ 125,991.59
		Total Money fund balance				\$ 125,991.59

FIG GARDEN ROTARY CLUB

BOARD OF DIRECTORS

A Duly Noticed Special Meeting of the Board Of Directors Of the Fig Garden Rotary Club was held at TorNino's Restaurant at 5080 North Blackstone Avenue, Fresno, California 93710 on Friday 24 January 2003.

Members Present:

Daniel Bonyhadi
John Skewes
Ron Fletcher
Scott Bristol
Matthew Merzoian
Rod Coburn
Doug Cords
Richard Saroyan
Eric Fogderude
Jamie Franklin

Guests:

Greg Baxter, Past President
Mike Elkins

President Eric called to order the meeting at 1:41 p.m.

It was MSC to approve the Nomination of Howard Reed as new Director.

Greg Baxter, Past President, and Mike Elkins, Past Foundation Treasurer, representing Playland/Storyland, presented a financial need for insurance premium coverage. Extensive discussion regarding this premium payment, the viability of the park venues and other potential opportunities for Club participation followed.

It was MSC to approve an on-demand, no interest loan to Playland/Storyland in the amount of \$5,000. At the Club's February Board meeting, Playland/Storyland representatives shall present to the Board the financial and business plans for the coming year and possible attractions that might be the focus of Club sponsorship. Decision as to disposition of the loan agreement to be made at February meeting.

Past President Mary Lou Gunn has asked the Board to focus on specific recipients of the funds generated by her employer (Clear Channel Communications) contributions to Fig Garden Rotary, as a result of our staffing the Great Chili Cookoff and the Jazz Festival. We are asked in the future to earmark funds for specific venues and document that to Clear Channel. This item will be discussed at next month's Board meeting.

The meeting was adjourned by President Eric Fogderude at 2:06 p.m.

Respectfully Submitted By Doug Cords, Ph.D., Club Secretary.

FIG GARDEN ROTARY CLUB

BOARD OF DIRECTORS

Regular Meeting: 19 February 2003:

-Members Present:

*Directors:

Jamie Franklin
Matt Merzoian
Howard Reed
Steve Rontell
Richard Saroyan
David Stepp

*Foundation Treasurer:

Ron Fletcher

*Past-President:

John T. Skewes

*President-Elect:

Rod Coburn

*President:

Eric Fogderude

*Treasurer:

Scott Bristol

*Others Present:

Past President John Heberger
Past President Greg Baxter
Mike Elkins

The meeting was called to order by President Eric Fogderude at 7:09 a.m. in the Boardroom of the Stoughton Davidson Accountancy Corporation at 2520 West Shaw Lane, Fresno, California 93711.

*CONSENT ITEMS:

*Minutes Of The 15 January 2003 Regular Board Meeting
*Minutes Of The 24 January 2003 Special Board Meeting
*Attendance For The Month Of January, 2003 = 83%
*Membership As Of 1 February 2003 = 106

It was MSC to approve the Consent Items as presented.

*TREASURER'S REPORT:

(Scott Bristol)

Scott noted the following balances in key accounts:

*\$22,056. in checking - Cal Fed
*\$16,591. in Morgan Stanley Dean Witter
*\$29,961. in Members' Current Accounts

The Treasurer noted cash flow has increased, a result of the January Member Billing. He will work with Jon Chessum shortly to pay the Foundation Paul Harris funds from new members, plus Club match.

Expenses were incurred for President-Elect Dr. Rod Coburn's official trip to the Rotary International Convention. With regard to the 24 January Special Board Meeting, a Note Receivable (on demand) was recorded from Playland/Storyland in the amount of \$5,000. Scott has a 6-year "paper trail" on all Club income and expenditures.

It was MSC to approve the Treasurer's Report as presented.

*SECRETARY'S REPORT:

(Doug Cords)

The Board cordially welcomed new Board Members Matt Merzoian and Howard Reed, each stepping forward early to fill unexpired terms of service.

Wink Chase extends his sincere appreciation to the Board for granting an "Excuse From Attendance Requirements" during his transition to employment in Southern California.

An extensive discussion regarding the format of the "Blue Book" followed. Bill Griffith will be asked to present to the Board next month a status report, costs for Blue Book Binders and format/presentation issues as the Club transitions from its old format to the digitized arena. The Sense Of The Board is to continue with this transition and not to return to the old format.

Avenues recently published the June-December 2002 Attendance Figures, per Board requirement. The Secretary asked each Board member to identify at least one Club member at the 61-65% Attendance Level and make calls before our Friday meetings to encourage attendance and/or make-ups.

At next month's meeting, Foundation Treasurer Ron Fletcher will ask for a motion to change official signators on Club accounts.

President Eric joined the Secretary in the sad announcement of the resignations of two former Past Presidents:

- *Don Asperger
- *Robin Baldwin

Extensive discussions with each, following resignation letters, were not successful in changes of minds and each member will be missed greatly. Don asked that he be included in "hands-on" work projects and the Club Service Directors were asked to invite him. He also wishes to continue as an electronic "Avenues" recipient.

The Secretary presented Don and Robin with their official Fig Garden Rotary Club Blue Badges, as a memento of years of productive service.

New Member Proposals:

JAMES M. ROGERS -

Principal in Edmonds Jewelers
Sponsors Are John Heberger and Dave Holden
Membership Committee Has Approved Proposal
Proposed Classification: Jewelry - Retail
Proposed Mentor: Bruce Rolph

It was MSC to approve the nomination.

DENNIS ARCHER -

Century Twenty-One-Adanalian And Vasques
Sponsors Are Eric Fogderude and Jay Roll
Membership Committee Has Approved Proposal
Proposed Classification: Real Estate - Commercial Sales
Proposed Mentor: Eric Fogderude

It was MSC to approve the nomination.

*SECRETARY'S REPORT, continued:

Secretary to immediately forward candidates' files to Bob Bergin for Rotary Information invitation.

*PRESIDENT-ELECT'S REPORT: (Rod Coburn)

Rod offered personal thanks for Board members' gift items and ticket sales for the upcoming Auction, and encouraged further efforts. His goal is for 100% member participation in the event, in some fashion.

Rod will soon attend the Pre-Pets Conference and the Pets conference.

On 26 April in Porterville, a Leadership Training event will take place; further information shall follow.

Rod circulated a copy of the "Board Contact Information" for revision and corrections.

There is confusion in some official venues regarding the name and location of our Club. "Fig Garden Rotary" should be noted as a Fresno, California club. Rod will look into the situation and report on recommendations.

It was MSC to elect Mike Graves to the Board, serving a two-year term in International Service.

*PAST PRESIDENT'S REPORT: (John T. Skewes)

In the interest of time, John deferred his floor time to other matters.

*PRESIDENT'S TIME: (Eric Fogderude)

President Eric circulated a form noting the "COG Mentors," and noted that Past Presidents have/are being asked to be a Mentor.

The Centennial Project is still in its identification stages, with the focus still being on a community-wide project. Our Club may bow out if a suitable venue cannot be located soon. The Community Service Committee will present a back-up, alternative program for our Club's consideration.

District Awards' deadline is 1 April 2003. Kathy Lindstrom is the District liason and President Eric has delivered information to all concerned, with request for submissions.

Jay Roll will head up a renewed Membership Drive.

Jon Chessum and Tom Ogden are working on Polio Plus and Paul Harris fund-raising programs.

It was MSC to have no Board meeting in the month of June, 2003.

*AVENUES OF SERVICE:

-Club Service: No report this month.

-Community Service:

(Richard Saroyan and Steve Rontell)

The "Night On Fifth Avenue" generated a net amount of \$26,151. Per the commitment to Nancy Hinds Hospice, it was MSC to approve funding in the amount of \$12,500. for the Bereavement Program.

It was MSC to approve funding in the amount of \$500. for our Bullard High School Interact Club, in recognition of their volunteer efforts in the successful fund-raiser at Fresno Lincoln/Mercury/Volvo.

For Sober Graduation Night, it was MSC to approve funding in the amount of \$750. each to Bullard High School and San Joaquin Memorial High School. The Directors shall encourage daughter of member Wink Chase, Lauren, to come to the Committee with a proposal for the recently-developed student organization at Bullard which she leads, focused on drinking/drug problems.

-Vocational Service:

(Dave Stepp and Matt Merzoian)

Upcoming will be Camp Royal interviews, with Jim Gibbs heading up the program this year.

To follow will be participation in the Scholarship Programs at Bullard High School, San Joaquin Memorial High School and Fresno City College.

-International Service:

(Jamie Franklin and Howard Reed)

Chris Lewis from the Wheelchair Foundation is being contacted to set up possible member participation in the actual delivery of the wheelchairs. The Directors requested the previously-approved check for \$18,500.

Howard attended a meeting on 1 February for the Outbound Exchange Program. Our student wishes to raise funds for expenses. Howard will ask Avenues to publish a notice of her availability for work and will also contact Bill Griffith to offer her services for data input on the Blue Book Project.

*OLD BUSINESS:

Past President Greg Baxter and Mike Elkins presented an update to the Board budgets and projections for Playland/Storyland, per the January Special Board Meeting. There have literally been three years of "downtime" at Playland, due to rides being condemned for new safety regulations. The Park remained partly open due to contributions and a State grant. The 2003 projections show the bank line of credit being paid off by year's end. Blair Looney of Charles Looney Advertising will donate advertising consultancy this year. Extensive discussion followed regarding the cost and income projections and the future of Playland and Storyland. Our Club is blessed with several members actively volunteering on the parks' Board Of Directors.

The loan matter is referred to the Community Service Avenue for recommendations on disposition of the \$5,000 on-demand loan and possible projects.

Sincere thanks were offered to the Board by Greg and Mike for coming to the aid of the park in a financial crunch time.

-NEW BUSINESS:

There was no New Business presented at this meeting.

*ADJOURNMENT: President Eric Adjourned The Meeting At 9:09 a.m.

*NEXT MEETING:: 19 March 2003

Respectfully Submitted By Doug Cords, Ph.D., Club Secretary.

Rotary Club of Fig Garden

Club Accounts

Balance sheet for period ending 31 January 03

Printed 2/15/03

ACCUMULATED FUNDS

Club Funds

Balance at beginning of year	\$56,352.89
Excess (Deficit) for period	\$15,097.85
Balance to Date	\$71,450.74

TOTAL FUNDS	\$71,450.74
--------------------	--------------------

Represented by:

ASSETS

Checking Account-Cal Fed	\$22,056.13
Morgan Stanley Dean Witter	\$16,591.61
Member's Current Accounts	\$29,961.00
Note Rec - Playland	\$5,000.00
Total Assets	\$73,608.74

LIABILITIES

PHF Clearing	\$325.00
Woodward Park Bench Project	\$1,500.00
Suspense	\$333.00
Total Liabilities	\$2,158.00

NET ASSETS	\$71,450.74
-------------------	--------------------

Rotary Club of Fig Garden

Club Accounts

Income & Expenditure: Current Month & Year to Date to January 03

Printed 2/15/03

	Current Month	Year to Date
INCOME		
Member Dues	\$0.00	\$26,875.00
Terminated Members	(\$125.00)	(\$125.00)
Admin Charge-New Members	\$160.00	\$320.00
Fines	(\$50.00)	\$11,462.50
Raffle	\$105.00	\$730.00
Interest	\$0.00	\$100.80
Roger Rockas	\$0.00	\$76.00
Retreat	\$0.00	\$3,901.00
Races	\$0.00	\$1,957.00
Tailgate	\$0.00	\$520.00
Offsite Lunches	\$0.00	\$732.00
Christmas Party	\$455.00	\$2,525.00
Gift Exchange/Toys for Tots	\$99.00	\$121.00
Auction	\$0.00	\$100.00
Miscellaneous Income	\$0.00	\$979.04
Total Income	\$644.00	\$50,274.34
EXPENDITURE		
R.I. Dues	\$2,483.00	\$5,616.75
District Dues	\$2,535.52	\$5,242.94
Supplies and Postage	\$298.75	\$1,594.70
Computer Expenses and Web Site	\$0.00	\$522.00
Officer Expense	\$515.00	\$3,997.01
Terminated Members	\$0.00	\$250.00
Miscellaneous Expense	\$0.00	\$1,572.00
Bank Charges	\$0.00	\$7.72
Lunch-Tornino's	\$352.00	\$830.50
Demotion Party	\$0.00	\$512.52
Banners, Badges, Pins	\$179.39	\$563.82
Hospitality and Fellowship	\$100.65	\$1,915.74
Rotary Information	\$62.47	\$62.47
Retreat	\$0.00	\$4,504.78
The Races	\$0.00	\$1,934.34
Mystery Dinner	\$0.00	\$34.62
Tailgate	\$82.11	\$82.11
Offsite Lunches	\$0.00	\$748.04
Christmas Party	\$0.00	\$3,242.81
Camp Royal	\$0.00	(\$58.38)
Christmas Food Basket	\$0.00	\$2,000.00
Total Expenditure	\$6,608.89	\$35,176.49
Excess (Deficit)	(\$5,964.89)	\$15,097.85

Rotary Club of Fig Garden

Club Accounts

Income & Expenditure: Comparison to Budget to January 03

Printed 2/15/03

	Current Month	Year to Date	Budget to Date	Variance
INCOME				
Member Dues	\$0.00	\$26,875.00	\$28,000.00	(\$1,125.00)
Terminated Members	(\$125.00)	(\$125.00)	\$0.00	(\$125.00)
Admin Charge-New Members	\$160.00	\$320.00	\$700.00	(\$380.00)
Fines	(\$50.00)	\$11,462.50	\$10,000.00	\$1,462.50
Raffle	\$105.00	\$730.00	\$700.00	\$30.00
Interest	\$0.00	\$100.80	\$350.00	(\$249.20)
Roger Rockas	\$0.00	\$76.00	\$0.00	\$76.00
Retreat	\$0.00	\$3,901.00	\$3,800.00	\$101.00
Races	\$0.00	\$1,957.00	\$0.00	\$1,957.00
Tailgate	\$0.00	\$520.00	\$720.00	(\$200.00)
Offsite Lunches	\$0.00	\$732.00	\$1,050.00	(\$318.00)
Christmas Party	\$455.00	\$2,525.00	\$3,000.00	(\$475.00)
Gift Exchange/Toys for Tots	\$99.00	\$121.00	\$0.00	\$121.00
Auction	\$0.00	\$100.00	\$0.00	\$100.00
Miscellaneous Income	\$0.00	\$979.04	\$350.00	\$629.04
Total Income	\$644.00	\$50,274.34	\$48,670.00	\$1,604.34
EXPENDITURE				
R.I. Dues	\$2,483.00	\$5,616.75	\$5,800.00	\$183.25
District Dues	\$2,535.52	\$5,242.94	\$5,800.00	\$557.06
Supplies and Postage	\$298.75	\$1,594.70	\$1,050.00	(\$544.70)
Computer Expenses and Web Site	\$0.00	\$522.00	\$210.00	(\$312.00)
Officer Expense	\$515.00	\$3,997.01	\$100.00	(\$3,897.01)
Terminated Members	\$0.00	\$250.00	\$1,200.00	\$950.00
Miscellaneous Expense	\$0.00	\$1,572.00	\$700.00	(\$872.00)
Bank Charges	\$0.00	\$7.72	\$0.00	(\$7.72)
Dist Conf and Assembly	\$0.00	\$0.00	\$250.00	\$250.00
Lunch-Tornino's	\$352.00	\$830.50	\$1,225.00	\$394.50
Programs	\$0.00	\$0.00	\$350.00	\$350.00
Speakers	\$0.00	\$0.00	\$1,050.00	\$1,050.00
Demotion Party	\$0.00	\$512.52	\$0.00	(\$512.52)
Bulletin	\$0.00	\$0.00	\$700.00	\$700.00
Banners, Badges, Pins	\$179.39	\$563.82	\$525.00	(\$38.82)
Hospitality and Fellowship	\$100.65	\$1,915.74	\$2,625.00	\$709.26
Blue Book	\$0.00	\$0.00	\$525.00	\$525.00
Rotary Information	\$62.47	\$62.47	\$175.00	\$112.53
Membership	\$0.00	\$0.00	\$350.00	\$350.00
Retreat	\$0.00	\$4,504.78	\$5,300.00	\$795.22
The Races	\$0.00	\$1,934.34	\$0.00	(\$1,934.34)
Mystery Dinner	\$0.00	\$34.62	\$0.00	(\$34.62)
Tailgate	\$82.11	\$82.11	\$860.00	\$777.89
Offsite Lunches	\$0.00	\$748.04	\$1,200.00	\$451.96
Christmas Party	\$0.00	\$3,242.81	\$4,000.00	\$757.19
Camp Royal	\$0.00	(\$58.38)	\$0.00	\$58.38
Christmas Food Basket	\$0.00	\$2,000.00	\$0.00	(\$2,000.00)
Community Projects	\$0.00	\$0.00	\$875.00	\$875.00
Bullard Interact	\$0.00	\$0.00	\$175.00	\$175.00
SJM Interact	\$0.00	\$0.00	\$175.00	\$175.00
Youth Exchange	\$0.00	\$0.00	\$175.00	\$175.00
Paul Harris	\$0.00	\$0.00	\$350.00	\$350.00
Total Expenditure	\$6,608.89	\$35,176.49	\$35,745.00	\$568.51
Excess (Deficit)	(\$5,964.89)	\$15,097.85	\$12,925.00	\$1,035.83

Rotary Club of Fig Garden

Club Accounts

Income & Expenditure: Current Year vs Previous Year to January 03

Printed 2/15/03

	Month		Year to Date	
	Current Year	Previous Year	Current Year	Previous Year
INCOME				
Member Dues	\$0.00	\$13,750.00	\$26,875.00	\$27,557.50
Terminated Members	(\$125.00)	\$0.00	(\$125.00)	\$0.00
Admin Charge-New Members	\$160.00	\$0.00	\$320.00	\$720.00
Fines	(\$50.00)	\$0.00	\$11,462.50	\$10,487.50
Raffle	\$105.00	\$60.00	\$730.00	\$906.00
Interest	\$0.00	\$0.00	\$100.80	\$236.34
Demotion Party	\$0.00	\$0.00	\$0.00	\$60.00
Roger Rockas	\$0.00	\$0.00	\$76.00	\$0.00
Retreat	\$0.00	\$0.00	\$3,901.00	\$3,575.00
Races	\$0.00	\$0.00	\$1,957.00	\$2,188.00
Tailgate	\$0.00	\$0.00	\$520.00	\$700.00
Offsite Lunches	\$0.00	\$0.00	\$732.00	\$801.00
Christmas Party	\$455.00	\$0.00	\$2,525.00	\$3,600.00
Gift Exchange/Toys for Tots	\$99.00	\$0.00	\$121.00	\$0.00
Auction	\$0.00	\$0.00	\$100.00	\$65.00
Miscellaneous Income	\$0.00	\$175.00	\$979.04	\$1,679.96
Community Projects	\$0.00	\$0.00	\$0.00	\$2,500.00
Wheelchair Project	\$0.00	\$140.00	\$0.00	\$140.00
Paul Harris	\$0.00	\$0.00	\$0.00	\$315.00
Total Income	\$644.00	\$14,125.00	\$50,274.34	\$55,531.30
EXPENDITURE				
R.I. Dues	\$2,483.00	\$0.00	\$5,616.75	\$2,694.04
District Dues	\$2,535.52	\$2,706.18	\$5,242.94	\$5,647.68
Supplies and Postage	\$298.75	\$109.93	\$1,594.70	\$839.12
Computer Expenses and Web Site	\$0.00	\$0.00	\$522.00	\$0.00
Officer Expense	\$515.00	\$0.00	\$3,997.01	\$38.21
Terminated Members	\$0.00	\$0.00	\$250.00	\$2,530.00
Miscellaneous Expense	\$0.00	\$0.00	\$1,572.00	\$303.00
Bank Charges	\$0.00	\$0.00	\$7.72	\$7.48
Lunch-Tornino's	\$352.00	\$0.00	\$830.50	\$1,054.50
FGR Foundation	\$0.00	(\$1,500.00)	\$0.00	\$5,000.00
Demotion Party	\$0.00	\$0.00	\$512.52	\$329.41
Bulletin	\$0.00	\$359.85	\$0.00	\$359.85
Banners, Badges, Pins	\$179.39	\$0.00	\$563.82	\$651.58
Hospitality and Fellowship	\$100.65	\$70.15	\$1,915.74	\$1,832.66
Blue Book	\$0.00	\$463.86	\$0.00	\$953.07
Rotary Information	\$62.47	\$0.00	\$62.47	\$182.25
Retreat	\$0.00	\$0.00	\$4,504.78	\$4,360.47
The Races	\$0.00	\$0.00	\$1,934.34	\$2,080.22
Mystery Dinner	\$0.00	\$0.00	\$34.62	\$0.00
Tailgate	\$82.11	\$0.00	\$82.11	\$823.76
Offsite Lunches	\$0.00	\$0.00	\$748.04	\$839.87
Christmas Party	\$0.00	\$264.31	\$3,242.81	\$4,981.19
Auction	\$0.00	\$218.26	\$0.00	\$218.26
Camp Royal	\$0.00	\$0.00	(\$58.38)	(\$66.83)
Christmas Food Basket	\$0.00	\$0.00	\$2,000.00	\$0.00
Community Projects	\$0.00	\$0.00	\$0.00	\$5,175.00
Youth Exchange	\$0.00	\$0.00	\$0.00	\$53.76
Paul Harris	\$0.00	\$1,500.00	\$0.00	\$1,500.00
Total Expenditure	\$6,608.89	\$4,192.54	\$35,176.49	\$42,388.55

Rotary Club of Fig Garden

Club Accounts

Income & Expenditure: CurrentYear vs Previous Year to January 03

Printed 2/15/03

	Month		Year to Date	
	Current Year	Previous Year	Current Year	Previous Year
Excess (Deficit)	(\$5,964.89)	\$9,932.46	\$15,097.85	\$13,142.75

FIG GARDEN ROTARY CLUB

FOUNDATION

BOARD OF DIRECTORS

Regular Meeting: 19 February 2003:

-Members Present:

*Directors:

Jamie Franklin
Matt Merzoian
Howard Reed
Steve Rontell
Richard Saroyan
David Stepp

*President:

Eric Fogderude

*Treasurer:

Scott Bristol

*Foundation Treasurer:

Ron Fletcher

*Past-President:

John T. Skewes

*President-Elect:

Rod Coburn

*Secretary:

Doug Cords

*Others Present:

Past President John Heberger
Past President Greg Baxter
Mike Elkins

The meeting was called to concurrent order by President Eric Fogderude with the Regular Board Meeting of the Fig Garden Rotary Club, in the Boardroom of the Stoughton Davidson Accountancy Corporation at 2520 West Shaw Lane, Suite 101, Fresno, California 93711 at 7:08 a.m.

*TREASURER'S REPORT:

(Ron Fletcher)

Due to family health issues, the Treasurer's Report is deferred and will be given next month.

*ADJOURNMENT: Concurrent With Regular Meeting, Adjourned At 9:09 a.m.

*NEXT MEETING: 19 March 2003

Respectfully Submitted By Doug Cords, Ph.D., Foundation Secretary.

FIG GARDEN ROTARY CLUB

BOARD OF DIRECTORS

-Regular Meeting: 19 March 2003:

-Members Present:

*Directors:

August Hioco
Matt Merzoian
Howard Reed
Steve Rontell
David Stepp

*Club Treasurer:

Scott Bristol

*President-Elect:

Rod Coburn

*Others Present:

Past President John Heberger
Debra Coe

*President:

Eric Fogderude

*Secretary:

Doug Cords

The meeting was called to order by President Eric Fogderude at 7:07 a.m. in the Boardroom of the Stoughton Davidson Accountancy Corporation at 2530 West Shaw Lane, Suite 101, Fresno, California 93711.

*CONSENT ITEMS:

*Minutes Of The 19 February 2003 Regular Board Meeting
*Attendance For The Month Of February, 2003 = 84%
*Membership As Of 1 March 2002 = 104,

It was MSC to approve the Consent Items as presented.

*TREASURER'S REPORT:

(Scott Bristol)

Scott noted the following balances, in key accounts:

Checking:	\$35,261.
Morgan Stanley Dean Witter	16,591.
Members' Accounts Receivable:	16,171.
Note Receivable/Playland:	5,000.

The Woodward Park Bench project has a liability of \$1,500.

Accounts are either on budget or ahead of budget for the fiscal year.

Scott reviewed the status of the Monthly Aged Trial President, a copy of which is given to the President. Some members have large Accounts Payable Balances - eight between \$600. and \$1,442. The President will contact each, with the goal of generating a monthly workout payment schedule.

It was MSC to approve the Treasurer's Report as presented.

*SECRETARY'S REPORT:

(Doug Cords)

A report was given of the COG Members who must attend a Board Meeting as part of the requirements of the Club:

- *Tony Carr
- *Fernando Morales
- *Joetta Winter
- *Doug Brinkley
- *Jim Rodgers
- *Dennis Archer

The "Clovis Unified School District Today" newspaper was circulated for review, as it carried a piece about Fig Garden Rotary Club's Program at Nelson School, spearheaded by Bill Robinson. The school shall greet a new Principal next year, Rich Smith, presently Principal at Dry Creek School. He is a dynamic, acclaimed leader who can be a key player in our relationship with the school.

The latest District Attendance Figures were circulated, from January; our Club leads the local clubs in average monthly attendance, a regular and strong pattern.

It was MSC to approve April 18, 2003, as a "Dark Day" to observe Good Friday. Secretary to notify Avenues Editor and TorNino's.

COG Member, per Daniel Bonyhadi, has completed all the requirements and his Blue Badge is ready for presentation at a Friday meeting, by President Eric Fogderude. Bob Whalen shall receive his Blue Badge on 28 March 2003.

Member Rob Morello has changed jobs and unfortunately displays severe attendance issues. Director Bonyhadi and the Secretary have worked with him to try to resolve, but travel precludes regular attendance. He has notified the President of his intention to resign. It is the will of the Board that this letter to be written be appropriately dated to reflect his last attendance in January. Secretary to so inform Rob.

The New Member Pipeline has no new candidates this month.

Dennis Archer and Jim Rodgers were inducted as new members on Friday, 14 March 2003.

The Board held an extensive discussion regarding the RI-chartered "E-Club" format and its potential for abuse in terms of make-ups. President-Elect Rod Coburn and the Secretary will bring to the Board a draft of a revised Attendance Credit policy, to include this E-Club scenario and others, in the near future.

*PRESIDENT ELECT'S REPORT:

No report this month.

*PRESIDENT-ELECT'S REPORT:

(Rod Coburn)

The Golf Team is assembled and ready for its annual participation in the Selma Rotary Club's Tournament.

*PRESIDENT-ELECT, Continued:

In his role as Auction Chair, Rod reported on Preliminary Numbers from the annual fund-raiser from 15 March, as follows:

\$55,585. in merchandise income
3,010. in income from raffle
\$58,595. deposited in bank .

This is non-inclusive of ticket sales. The "Ballpark Return" is in the neighborhood of \$50,000. Several hardware/equipment purchases were made this year, which shall be utilized in future fund-raising events.

The PETS Conference was productive and informative.

Member Tom Ogden will take over as "Senior Co-Chair" For the Foundation.

Rod is looking ahead to schedule next year's Auction, around possible local venue scheduling conflicts which might detract from our efforts.

On April 26th, returning Board Members are encouraged to attend a Training Meeting, held at Porterville College.

On April 22-25, 2004, the District Conference shall be held at Tenaya Lodge.

Rod delivered to Avenues Editor an updated Area Club Calendar of meetings, times and places, for our members' make-ups.

*PRESIDENT'S TIME: (Eric Fogderude)

On May 16-18, the next District Conference will be held. Applications are available from Eric, and participation is stressed and important.

The District's Newsletter was circulated for members' reading.

A new edition of the "Club Roster" has been published and will be available shortly. The goal is to revise and publish each six months.

There will be forthcoming a Membership Drive.

A block of tickets for "Wrinkles" has been set aside for members' purchases.

The "Centennial Project" proposal for an Educational Center at Scout Island was discussed. A Blue Ribbon Committee shall be formed immediately to recommend to the Board options and strategy for analyzing the possibility of our participation in this long-term (at least 2 years) project. President-Elect Rod Coburn will spearhead the group.

Matching funds are still available, per prior Board Action, for members to utilize in making Paul Harris Contributions. It was MSC to extend the deadline to April 15, 2003. Past President Heberger noted, with Board support, that the members of the Foundation Leadership propose a "matching funds" arena, which might be different from that which the Board approved.

*AVENUES OF SERVICE:

-Club Service: (August Hioco)

April 25: Golf Tournament and COG Social - the Club's meeting this Friday
(Secretary to notify TorNino's and Avenues)

May 24: Mystery Dinner

June 6: Wrinkles (tentative)

Late June: Demotion Party

Some members have requested earlier notification of Club activities, so scheduling can be effected. The Chairs will happily get out notices as soon as possible, continuing their strong efforts to support members.

It was suggested that the Club might utilize the Rotary Amphitheater for a future event.

-Community Service: (Steve Rontell)

It was MSC to allocate the sum of \$2500. to Break The Barriers for purchase of tumbling/landing mats, hopefully with the FGR logo affixed.

It was MSC to approve the sum of \$500. for the Bullard Talent School, to help fund travel to New York for the "Festival Of Gold" Music Competition.

Debra Coe and John Heberger gave a superb presentation about the "Spirit Of Woman Of California, Incorporated." It was MSC to allocate the sum of \$7,450. for purchase of equipment and supplies for apartment refurnishings to support this program.

-Vocational Service: (Dave Stepp)

On May 4, the high school students and their counselors will join the Club's meeting to receive scholarships and recognition.

Camp Royal interview dates will be set soon.

-International Service: (Howard Reed)

On 24 March, Rotary Club Of Fresno will have a "wheelchair project" program. Jamie Franklin will visit the Club, to learn and be therefore well versed in the "ins and outs" of the program. The guest speaker is from Costa Rica, where a previous donation was made.

*OLD BUSINESS:

The "Centennial Project" was previously covered under "President's Time."

*NEW BUSINESS:

There was no New Business this meeting.

*ADJOURNMENT: President Eric adjourned the meeting at 8:56 a.m.

*NEXT MEETING: 16 April 2003.

Respectfully Submitted By Doug Cords, Ph.D., Club Secretary.

Rotary Club of Fig Garden

Club Accounts

Balance sheet for period ending 28 February 03

Printed 3/17/03

ACCUMULATED FUNDS

Club Funds

Balance at beginning of year	\$56,352.89
Excess (Deficit) for period	\$14,846.57
Balance to Date	\$71,199.46

TOTAL FUNDS	<u>\$71,199.46</u>
--------------------	--------------------

Represented by:

ASSETS

Checking Account-Cal Fed	\$35,261.85
Morgan Stanley Dean Witter	\$16,591.61
Member's Current Accounts	\$16,171.00
Note Rec - Playland	\$5,000.00
Total Assets	<u>\$73,024.46</u>

LIABILITIES

PHF Clearing	\$325.00
Woodward Park Bench Project	\$1,500.00
Total Liabilities	<u>\$1,825.00</u>

NET ASSETS	<u>\$71,199.46</u>
-------------------	--------------------

Rotary Club of Fig Garden

Club Accounts

Income & Expenditure: Current Month & Year to Date to February 03

Printed 3/ 8/03

	Current Month	Year to Date
INCOME		
Member Dues	\$0.00	\$26,875.00
Terminated Members	\$0.00	(\$125.00)
Admin Charge-New Members	\$0.00	\$320.00
Fines	\$0.00	\$11,462.50
Raffle	\$68.00	\$798.00
Interest	\$0.00	\$100.80
Roger Rockas	\$2,587.50	\$2,663.50
Retreat	\$0.00	\$3,901.00
Races	\$0.00	\$1,957.00
Tailgate	\$0.00	\$520.00
Offsite Lunches	\$0.00	\$732.00
Christmas Party	\$0.00	\$2,525.00
Gift Exchange/Toys for Tots	\$0.00	\$121.00
Auction	\$0.00	\$100.00
Miscellaneous Income	\$0.00	\$979.04
Total Income	\$2,655.50	\$52,929.84
EXPENDITURE		
R.I. Dues	\$0.00	\$5,616.75
District Dues	\$0.00	\$5,242.94
Supplies and Postage	\$0.00	\$1,594.70
Computer Expenses and Web Site	\$0.00	\$522.00
Officer Expense	\$0.00	\$3,997.01
Terminated Members	\$0.00	\$250.00
Miscellaneous Expense	\$56.78	\$1,628.78
Bank Charges	\$0.00	\$7.72
Lunch-Tornino's	\$0.00	\$830.50
Programs	\$200.00	\$200.00
Demotion Party	\$0.00	\$512.52
Banners, Badges, Pins	\$0.00	\$563.82
Hospitality and Fellowship	\$0.00	\$1,915.74
Rotary Information	\$0.00	\$62.47
Roger Rockas	\$2,550.00	\$2,550.00
Retreat	\$0.00	\$4,504.78
The Races	\$0.00	\$1,934.34
Mystery Dinner	\$0.00	\$34.62
Tailgate	\$0.00	\$82.11
Offsite Lunches	\$0.00	\$748.04
Christmas Party	\$0.00	\$3,242.81
Camp Royal	\$0.00	(\$58.38)
Christmas Food Basket	\$0.00	\$2,000.00
Total Expenditure	\$2,806.78	\$37,983.27
Excess (Deficit)	(\$151.28)	\$14,946.57

Rotary Club of Fig Garden

Club Accounts

Income & Expenditure: Current Year vs Previous Year to February 03

Printed 3/ 8/03

	Month		Year to Date	
	Current Year	Previous Year	Current Year	Previous Year
INCOME				
Member Dues	\$0.00	\$0.00	\$26,875.00	\$27,557.50
Terminated Members	\$0.00	\$0.00	(\$125.00)	\$0.00
Admin Charge-New Members	\$0.00	\$0.00	\$320.00	\$720.00
Fines	\$0.00	\$0.00	\$11,462.50	\$10,487.50
Raffle	\$68.00	\$242.00	\$798.00	\$1,148.00
Interest	\$0.00	\$0.00	\$100.80	\$236.34
Demotion Party	\$0.00	\$0.00	\$0.00	\$60.00
Roger Rockas	\$2,587.50	\$0.00	\$2,663.50	\$0.00
Retreat	\$0.00	\$0.00	\$3,901.00	\$3,575.00
Races	\$0.00	\$0.00	\$1,957.00	\$2,188.00
Tailgate	\$0.00	\$0.00	\$520.00	\$700.00
Offsite Lunches	\$0.00	\$0.00	\$732.00	\$801.00
Christmas Party	\$0.00	\$0.00	\$2,525.00	\$3,600.00
Gift Exchange/Toys for Tots	\$0.00	\$0.00	\$121.00	\$0.00
Auction	\$0.00	\$450.00	\$100.00	\$515.00
Miscellaneous Income	\$0.00	\$0.00	\$979.04	\$1,679.96
Community Projects	\$0.00	\$0.00	\$0.00	\$2,500.00
Wheelchair Project	\$0.00	\$0.00	\$0.00	\$140.00
Paul Harris	\$0.00	\$0.00	\$0.00	\$315.00
Total Income	\$2,655.50	\$692.00	\$52,929.84	\$56,223.30
EXPENDITURE				
R.I. Dues	\$0.00	\$2,661.00	\$5,616.75	\$5,355.04
District Dues	\$0.00	\$0.00	\$5,242.94	\$5,647.68
Supplies and Postage	\$0.00	\$35.66	\$1,594.70	\$874.78
Computer Expenses and Web Site	\$0.00	\$0.00	\$522.00	\$0.00
Officer Expense	\$0.00	\$240.75	\$3,997.01	\$278.96
Terminated Members	\$0.00	\$0.00	\$250.00	\$2,530.00
Miscellaneous Expense	\$56.78	\$586.00	\$1,628.78	\$889.00
Bank Charges	\$0.00	\$0.00	\$7.72	\$7.48
Lunch-Tornino's	\$0.00	\$0.00	\$830.50	\$1,054.50
FGR Foundation	\$0.00	\$0.00	\$0.00	\$5,000.00
Programs	\$200.00	\$0.00	\$200.00	\$0.00
Demotion Party	\$0.00	\$0.00	\$512.52	\$329.41
Bulletin	\$0.00	\$0.00	\$0.00	\$359.85
Banners, Badges, Pins	\$0.00	\$127.44	\$563.82	\$779.02
Hospitality and Fellowship	\$0.00	\$0.00	\$1,915.74	\$1,832.66
Blue Book	\$0.00	\$0.00	\$0.00	\$953.07
Rotary Information	\$0.00	\$0.00	\$62.47	\$182.25
Roger Rockas	\$2,550.00	\$0.00	\$2,550.00	\$0.00
Retreat	\$0.00	\$0.00	\$4,504.78	\$4,360.47
The Races	\$0.00	\$0.00	\$1,934.34	\$2,080.22
Mystery Dinner	\$0.00	\$0.00	\$34.62	\$0.00
Tailgate	\$0.00	\$0.00	\$82.11	\$823.76
Offsite Lunches	\$0.00	\$0.00	\$748.04	\$839.87
Christmas Party	\$0.00	\$0.00	\$3,242.81	\$4,981.19
Valentines Day	\$0.00	\$151.45	\$0.00	\$151.45
Auction	\$0.00	\$500.00	\$0.00	\$718.26
Camp Royal	\$0.00	\$0.00	(\$58.38)	(\$66.83)
Christmas Food Basket	\$0.00	\$0.00	\$2,000.00	\$0.00
Community Projects	\$0.00	\$0.00	\$0.00	\$5,175.00
Youth Exchange	\$0.00	\$0.00	\$0.00	\$53.76

Rotary Club of Fig Garden

Club Accounts

Income & Expenditure: CurrentYear vs Previous Year to February 03

Printed 3/ 8/03

	Month		Year to Date	
	Current Year	Previous Year	Current Year	Previous Year
Paul Harris	\$0.00	\$0.00	\$0.00	\$1,500.00
Total Expenditure	\$2,806.78	\$4,302.30	\$37,983.27	\$46,690.85
Excess (Deficit)	(\$151.28)	(\$3,610.30)	\$14,946.57	\$9,532.45

Rotary Club of Fig Garden

Club Accounts

Income & Expenditure: Comparison to Budget to February 03

Printed 3/ 8/03

	Current Month	Year to Date	Budget to Date	Variance
INCOME				
Member Dues	\$0.00	\$26,875.00	\$28,000.00	(\$1,125.00)
Terminated Members	\$0.00	(\$125.00)	\$0.00	(\$125.00)
Admin Charge-New Members	\$0.00	\$320.00	\$800.00	(\$480.00)
Fines	\$0.00	\$11,462.50	\$10,000.00	\$1,462.50
Raffle	\$68.00	\$798.00	\$800.00	(\$2.00)
Interest	\$0.00	\$100.80	\$400.00	(\$299.20)
Roger Rockas	\$2,587.50	\$2,663.50	\$0.00	\$2,663.50
Retreat	\$0.00	\$3,901.00	\$3,800.00	\$101.00
Races	\$0.00	\$1,957.00	\$0.00	\$1,957.00
Tailgate	\$0.00	\$520.00	\$720.00	(\$200.00)
Offsite Lunches	\$0.00	\$732.00	\$1,200.00	(\$468.00)
Christmas Party	\$0.00	\$2,525.00	\$3,000.00	(\$475.00)
Gift Exchange/Toys for Tots	\$0.00	\$121.00	\$0.00	\$121.00
Auction	\$0.00	\$100.00	\$0.00	\$100.00
Miscellaneous Income	\$0.00	\$979.04	\$400.00	\$579.04
Total Income	\$2,655.50	\$52,929.84	\$49,120.00	\$3,809.84
EXPENDITURE				
R.I. Dues	\$0.00	\$5,616.75	\$5,800.00	\$183.25
District Dues	\$0.00	\$5,242.94	\$5,800.00	\$557.06
Supplies and Postage	\$0.00	\$1,594.70	\$1,200.00	(\$394.70)
Computer Expenses and Web Site	\$0.00	\$522.00	\$240.00	(\$282.00)
Officer Expense	\$0.00	\$3,997.01	\$450.00	(\$3,547.01)
Terminated Members	\$0.00	\$250.00	\$1,200.00	\$950.00
Miscellaneous Expense	\$56.78	\$1,628.78	\$800.00	(\$828.78)
Bank Charges	\$0.00	\$7.72	\$0.00	(\$7.72)
Dist Conf and Assembly	\$0.00	\$0.00	\$250.00	\$250.00
Lunch-Tornino's	\$0.00	\$830.50	\$1,400.00	\$569.50
Programs	\$200.00	\$200.00	\$400.00	\$200.00
Speakers	\$0.00	\$0.00	\$1,200.00	\$1,200.00
Demotion Party	\$0.00	\$512.52	\$0.00	(\$512.52)
Bulletin	\$0.00	\$0.00	\$800.00	\$800.00
Banners, Badges, Pins	\$0.00	\$563.82	\$600.00	\$36.18
Hospitality and Fellowship	\$0.00	\$1,915.74	\$3,000.00	\$1,084.26
Blue Book	\$0.00	\$0.00	\$600.00	\$600.00
Rotary Information	\$0.00	\$62.47	\$200.00	\$137.53
Membership	\$0.00	\$0.00	\$400.00	\$400.00
Roger Rockas	\$2,550.00	\$2,550.00	\$0.00	(\$2,550.00)
Retreat	\$0.00	\$4,504.78	\$5,300.00	\$795.22
The Races	\$0.00	\$1,934.34	\$0.00	(\$1,934.34)
Mystery Dinner	\$0.00	\$34.62	\$0.00	(\$34.62)
Tailgate	\$0.00	\$82.11	\$860.00	\$777.89
Offsite Lunches	\$0.00	\$748.04	\$1,200.00	\$451.96
Christmas Party	\$0.00	\$3,242.81	\$4,000.00	\$757.19
Camp Royal	\$0.00	(\$58.38)	\$0.00	\$58.38
Christmas Food Basket	\$0.00	\$2,000.00	\$0.00	(\$2,000.00)
Community Projects	\$0.00	\$0.00	\$1,000.00	\$1,000.00
Bullard Interact	\$0.00	\$0.00	\$200.00	\$200.00
SJM Interact	\$0.00	\$0.00	\$200.00	\$200.00
Youth Exchange	\$0.00	\$0.00	\$200.00	\$200.00
Paul Harris	\$0.00	\$0.00	\$400.00	\$400.00
Total Expenditure	\$2,806.78	\$37,983.27	\$37,700.00	(\$283.27)

Rotary Club of Fig Garden

Club Accounts

Income & Expenditure: Comparison to Budget to February 03

Printed 3/ 8/03

	Current Month	Year to Date	Budget to Date	Variance
Excess (Deficit)	(\$151.28)	\$14,946.57	\$11,420.00	\$4,093.11

FIG GARDEN ROTARY CLUB

FOUNDATION
BOARD OF DIRECTORS

-Regular Meeting: 19 March 2003:

-Members Present:

*Directors:

August Hioco
Matt Merzoian
Howard Reed
Steve Rontell
David Stepp

*Club Treasurer:

Scott Bristol

*President-Elect:

Rod Coburn

*President:

Eric Fogderude

*Secretary:

Doug Cords

*Others Present:

Past President John Heberger
Debra Coe

The meeting was called to concurrent order by President Eric Fogderude with the Regular Board Meeting of the Fig Garden Rotary Club in the Boardroom of the Stoughton Davidson Accountancy Corporation at 2530 West Shaw Lane, Suite 101, Fresno, California at 7:07 a.m.

*TREASURER'S REPORT:

Ill health precluded participation by Foundation Treasurer Fletcher. Because this marks two months without Financial Reports, President Eric will e-mail/fax/mail both sets of Financials (January and February) to Board Members as they become available from the Treasurer.

*ADJOURNMENT:: Concurrent With Regular Meeting, Adjourned At 8:56 a.m.

*NEXT MEETING: 16 April 2003

Respectfully Submitted By Doug Cords, Ph.D., Foundation Secretary.

FIG GARDEN ROTARY CLUB

BOARD OF DIRECTORS

*Regular Meeting: 16 April 2003:

-Members Present:

*Directors:

Daniel Bonyhadi
Jamie Franklin
August Hioco
Matt Merzoian
Howard Reed
Steve Rontell
Richard Saroyan

*President:

Eric Fogderude

*Treasurer:

Scott Bristol

*Foundation Treasurer:

Ron Fletcher

*Secretary:

Doug Cords

*Past President:

John Skewes

*President-Elect:

Rod Coburn

The meeting was called to order by President Eric Fogderude at 7:04 a.m. in the Boardroom of the Stoughton Davidson Accountancy Corporation at 2530 West Shaw Lane, Suite 101, Fresno, California 93711.

*INITIAL BUSINESS:

President Eric Fogderude re-nominated Director Daniel Bonyhadi to the Board, a result of business pressures necessitating his missing three Board Meetings. It was MSC to approve the re-nomination.

Note: Director David Stepp is disqualified from the Board due to his missing three meetings during this Rotary year.

*CONSENT ITEMS:

*Minutes Of The 19 March 2003 Regular Board Meeting
*Attendance For Month Of March 2003 = 75%
*Membership As Of 1 April 2003 = 105

It was MSC to approve the Consent Items as presented.

*TREASURER'S REPORT:

(Scott Bristol)

Scott reviewed current accounts, as follows:

*Cash: \$36,634.
*Morgan Stanley: 16,625.
*Members' Current Accounts: 16,735.
*Playland Note Receivable: 5,000.
*Totals: \$74,994.

*TREASURER'S REPORT, Continued:

Fine income will be posted this month. The Club is still comfortably running ahead of Budget.

President Eric sent out polite letters to members with accounts in arrears, to contact him and/or Scott Bristol to try to get all accounts paid in full before the end of this Rotary year.

It was MSC to approve the Treasurer's Report as presented.

*SECRETARY'S REPORT: (Doug Cords)

Due to attendance difficulties, member Rob Morello has been terminated from the Club. He has taken a new position with huge travel obligations. Rob noted to Director Daniel Bonyhadi he looked forward to returning to membership in a year.

Member Craig Gallego, owner of Hodge And Sons, lost both his tailor and only sales professional and is running his store alone. It was MSC to grant Craig an Excuse From Attendance Requirements for a period of 90 days.

The COG Leaders will return the Secretary to the E-mail list to denote Friday working assignments for ticket/raffle and badge box. COG Tony Carr is not meeting even minimum COG requirements. Mentor Norm Fletcher will be contacted to hopefully help rectify the situation, report from President Eric next month to the Board.

It was MSC to nominate Dr. Rod Coburn as the Club's first Official Delegate to the Rotary International 2003-2004 Convention in Brisbane, Australia. Secretary presented Rod with his official documentation. Fig Garden Rotary Club has one more delegate position open. President Eric will offer this slot to members, at a Friday meeting and in Avenues. Pending this outcome, next month the Board will assign our second voting slot.

District Attendance Figures for February were circulated. Our Club leads all local clubs in monthly average attendance.

-New Member Proposal-

DARRYL BOOTH

Decade Software Company

Sponsors Are August Hioco and Sasan Rahmatian
Membership Has Approved
Proposed Classification: Computers-Software Development

It was MSC to approve the Nomination. Secretary to forward immediately to Bob Bergin for Rotary Information.

*PRESIDENT-ELECT'S REPORT: (Rod Coburn)

Rod noted strong attendance interest for the upcoming Conference. Auction thank-you letters, bogged down with software, are going out shortly.

*PRESIDENT-ELECT'S REPORT, Continued:

A lengthy discussion ensued regarding what actual physical equipment the Club owns, specifically hardware and related items and exactly the location of each piece. Security, insurance and physical condition issues prompted the coverage of this topic. President Eric will report to the Board shortly on this important issue.

*PAST PRESIDENT'S REPORT: (John Skewes)

In the interest of time, John omitted his comments.

*PRESIDENT'S TIME: (Eric Fogderude)

The District Conference will be 16-18 May. President Eric offered a carpool for the Saturday events only, going and returning that same day.

25 April is the deadline to submit proposed modifications for the Rotary International Constitution.

Eric circulated the Harvest Report, our District Newsletter.

A thank you letter from Play It Safe International was circulated.

The Membership Roster is completed and will be available at the Club's next meeting, 2 May.

The new Blue Book Binders have arrived, putting into process the overall revision of our membership book.

It was MSC to move the amount of \$10,000. in Club Funds to the Foundation, for the Permanent Funds. Early-on in President Rod's year, this issue will be re-visited, with the hope of transferring more funds into the Permanent Funds account.

President Eric encouraged all Directors for next month's meeting to have a formal report prepared denoting key accomplishments this Rotary year and recommendations for next year.

*AVENUES OF SERVICE:

-Club Service: (Daniel Bonyhadi and August Hioco)

The Golf Day and COG Social will be held on 25 April. Upcoming events are a possible Mystery Dinner, Wrinkles and President Eric's Demotion Party.

Director August Hioco shared his genuine appreciation for the key leadership of his Co-Director Daniel Bonyhadi.

-Community Service: (Richard Saroyan and Steve Rontell)

It was MSC to allocate up to the sum of \$1,500. to help fund the purchase of a coin counting machine for the Leukemia and Lymphoma Society, per request through Dave Kyle of East Fresno Rotary, the Society's Director. Other funds are possibly available from local Rotary Clubs.

Note: Past-President J. T. Skewes took over the meeting in Eric's stead.

-Community Service, continued:

It was MSC to approve funding in the amount of \$2,500. for the Leadership Fresno project at the Marjoree Mason Center. Member Stacy Rianda is the point person. The funds will create a Self-Help Resource Center, with books and videos. President-Elect Rod requested that the Club receive appropriate signage in the Center to recognize our help.

There remain approximately \$8,000. of Community Service Funds. The next focus will be to identify a Fig Garden Rotary Club possible Centennial Project.

-Vocational Service: (Matt Merzoian)

The Camp Royal applications from Bullard High School are in and the Personal Interview process will be upcoming, Treasurer Scott Bristol asked to join the Selection Committee.

School Scholarships at Bullard High School, San Joaquin Memorial High School and Fresno City College are continuing.

-International Service: (Jamie Franklin and Howard Reed)

Howard is the point person for this next week's hosting of the Group Study Exchange Team from the country of Chile. They arrive on Saturday 19 April. Part of our responsibilities is to transport the members to the Conference.

Extensive discussions ensued regarding the country which will be the ultimate recipient of our Wheelchair Foundation gifts. Director Jamie Franklin has been in contact often with the Foundation, as well as other Rotarians who have experience with this venue. The countries of Ecuador and Costa Rica were identified and confirmed by Wheelchair International as being acceptable beneficiaries. After extensive discussion, it was MSC to identify Ecuador as our Club's first choice and to go forward.

*OLD BUSINESS:

The local clubs' Centennial Project, a Proposed Center on the San Joaquin River discussed last month, has been tabled due to regulatory issues.

*NEW BUSINESS:

The possible restoration of the Bullard High School Theater, probably named after our Club, will be investigated and reported on in the future.

*ADJOURNMENT: Adjourned by Past-President John Skewes at 8:41 a.m.

*NEXT MEETING: 21 May 2003

Respectfully Submitted By Doug Cords, Ph.D.

Rotary Club of Fig Garden

Club Accounts

Balance sheet for period ending 31 March 03

Printed 4/15/03

ACCUMULATED FUNDS

Club Funds

Balance at beginning of year	\$56,352.89
Excess (Deficit) for period	\$17,566.43
Balance to Date	\$73,919.32

TOTAL FUNDS	<u>\$73,919.32</u>
--------------------	--------------------

Represented by:

ASSETS

Checking Account-Cal Fed	\$36,634.23
Morgan Stanley Dean Witter	\$16,625.09
Member's Current Accounts	\$16,735.00
Note Rec - Playland	\$5,000.00
Total Assets	<u>\$74,994.32</u>

LIABILITIES

PHF Clearing	(\$425.00)
Woodward Park Bench Project	\$1,500.00
Total Liabilities	<u>\$1,075.00</u>

NET ASSETS	<u>\$73,919.32</u>
-------------------	--------------------

Rotary Club of Fig Garden

Club Accounts

Income & Expenditure: Current Month & Year to Date to March 03

Printed 4/15/03

	Current Month	Year to Date
INCOME		
Member Dues	\$250.00	\$27,125.00
Terminated Members	\$0.00	(\$125.00)
Admin Charge-New Members	\$155.00	\$475.00
Fines	\$0.00	\$11,462.50
Raffle	\$188.00	\$986.00
Interest	\$33.48	\$134.28
Roger Rockas	\$0.00	\$2,663.50
Retreat	\$0.00	\$3,901.00
Races	\$0.00	\$1,957.00
Tailgate	\$0.00	\$520.00
Offsite Lunches	\$480.00	\$1,212.00
Christmas Party	\$0.00	\$2,525.00
Gift Exchange/Toys for Tots	\$0.00	\$121.00
Auction	\$4,475.00	\$4,575.00
Miscellaneous Income	\$793.03	\$1,772.07
Total Income	\$6,374.51	\$59,304.35
EXPENDITURE		
R.I. Dues	\$0.00	\$5,616.75
District Dues	\$0.00	\$5,242.94
Supplies and Postage	\$111.00	\$1,705.70
Computer Expenses and Web Site	\$0.00	\$522.00
Officer Expense	\$0.00	\$3,997.01
Terminated Members	\$0.00	\$250.00
Miscellaneous Expense	\$0.00	\$1,628.78
Bank Charges	\$0.00	\$7.72
Lunch-Tornino's	\$432.50	\$1,263.00
Programs	\$0.00	\$200.00
Demotion Party	\$0.00	\$512.52
Banners, Badges, Pins	\$0.00	\$563.82
Hospitality and Fellowship	\$0.00	\$1,915.74
Rotary Information	\$0.00	\$62.47
Roger Rockas	\$0.00	\$2,550.00
Retreat	\$1,469.90	\$5,974.68
The Races	\$0.00	\$1,934.34
Mystery Dinner	\$0.00	\$34.62
Field Trips	\$793.03	\$793.03
Tailgate	\$0.00	\$82.11
Offsite Lunches	\$0.00	\$748.04
Christmas Party	\$0.00	\$3,242.81
Valentines Day	\$93.43	\$93.43
Auction	\$754.79	\$854.79
Camp Royal	\$0.00	(\$58.38)
Christmas Food Basket	\$0.00	\$2,000.00
Total Expenditure	\$3,654.65	\$41,737.92
Excess (Deficit)	\$2,719.86	\$17,566.43

Rotary Club of Fig Garden

Club Accounts

Income & Expenditure: Current Year vs Previous Year to March 03

Printed 4/15/03

	Month		Year to Date	
	Current Year	Previous Year	Current Year	Previous Year
INCOME				
Member Dues	\$250.00	\$0.00	\$27,125.00	\$27,557.50
Terminated Members	\$0.00	\$0.00	(\$125.00)	\$0.00
Admin Charge-New Members	\$155.00	\$0.00	\$475.00	\$720.00
Fines	\$0.00	\$5,157.25	\$11,462.50	\$15,644.75
Raffle	\$188.00	\$95.00	\$986.00	\$1,243.00
Interest	\$33.48	\$59.26	\$134.28	\$295.60
Demotion Party	\$0.00	\$0.00	\$0.00	\$60.00
Roger Rockas	\$0.00	\$0.00	\$2,663.50	\$0.00
Retreat	\$0.00	\$0.00	\$3,901.00	\$3,575.00
Races	\$0.00	\$0.00	\$1,957.00	\$2,188.00
Tailgate	\$0.00	\$0.00	\$520.00	\$700.00
Offsite Lunches	\$480.00	\$0.00	\$1,212.00	\$801.00
Christmas Party	\$0.00	\$0.00	\$2,525.00	\$3,600.00
Gift Exchange/Toys for Tots	\$0.00	\$0.00	\$121.00	\$0.00
Auction	\$4,475.00	\$5,720.00	\$4,575.00	\$6,235.00
Miscellaneous Income	\$793.03	\$40.00	\$1,772.07	\$1,719.96
Community Projects	\$0.00	\$0.00	\$0.00	\$2,500.00
Wheelchair Project	\$0.00	\$0.00	\$0.00	\$140.00
Paul Harris	\$0.00	\$0.00	\$0.00	\$315.00
Total Income	\$6,374.51	\$11,071.51	\$59,304.35	\$67,294.81
EXPENDITURE				
R.I. Dues	\$0.00	\$0.00	\$5,616.75	\$5,355.04
District Dues	\$0.00	\$0.00	\$5,242.94	\$5,647.68
Supplies and Postage	\$111.00	\$265.78	\$1,705.70	\$1,140.56
Computer Expenses and Web Site	\$0.00	\$0.00	\$522.00	\$0.00
Officer Expense	\$0.00	\$330.00	\$3,997.01	\$608.96
Terminated Members	\$0.00	\$0.00	\$250.00	\$2,530.00
Miscellaneous Expense	\$0.00	\$0.00	\$1,628.78	\$889.00
Bank Charges	\$0.00	\$0.00	\$7.72	\$7.48
Lunch-Tornino's	\$432.50	\$714.00	\$1,263.00	\$1,768.50
FGR Foundation	\$0.00	\$0.00	\$0.00	\$5,000.00
Programs	\$0.00	\$86.53	\$200.00	\$86.53
Demotion Party	\$0.00	\$0.00	\$512.52	\$329.41
Bulletin	\$0.00	\$0.00	\$0.00	\$359.85
Banners, Badges, Pins	\$0.00	\$0.00	\$563.82	\$779.02
Hospitality and Fellowship	\$0.00	\$302.89	\$1,915.74	\$2,135.55
Blue Book	\$0.00	\$34.00	\$0.00	\$987.07
Rotary Information	\$0.00	\$0.00	\$62.47	\$182.25
Roger Rockas	\$0.00	\$0.00	\$2,550.00	\$0.00
Retreat	\$1,469.90	\$300.00	\$5,974.68	\$4,660.47
The Races	\$0.00	\$0.00	\$1,934.34	\$2,080.22
Mystery Dinner	\$0.00	\$0.00	\$34.62	\$0.00
Field Trips	\$793.03	\$0.00	\$793.03	\$0.00
Tailgate	\$0.00	\$0.00	\$82.11	\$823.76
Offsite Lunches	\$0.00	\$0.00	\$748.04	\$839.87
Christmas Party	\$0.00	\$0.00	\$3,242.81	\$4,981.19
Valentines Day	\$93.43	\$0.00	\$93.43	\$151.45
Auction	\$754.79	\$3,760.00	\$854.79	\$4,478.26
Camp Royal	\$0.00	\$0.00	(\$58.38)	(\$66.83)
Christmas Food Basket	\$0.00	\$0.00	\$2,000.00	\$0.00
Community Projects	\$0.00	\$0.00	\$0.00	\$5,175.00
Youth Exchange	\$0.00	\$0.00	\$0.00	\$53.76

Rotary Club of Fig Garden

Club Accounts

Income & Expenditure: CurrentYear vs Previous Year to March 03

Printed 4/15/03

	Month		Year to Date	
	Current Year	Previous Year	Current Year	Previous Year
Paul Harris	\$0.00	\$0.00	\$0.00	\$1,500.00
Total Expenditure	\$3,654.65	\$5,793.20	\$41,737.92	\$52,484.05
Excess (Deficit)	\$2,719.86	\$5,278.31	\$17,566.43	\$14,810.76

Rotary Club of Fig Garden

Club Accounts

Income & Expenditure: Comparison to Budget to March 03

Printed 4/15/03

	Current Month	Year to Date	Budget to Date	Variance
INCOME				
Member Dues	\$250.00	\$27,125.00	\$28,000.00	(\$875.00)
Terminated Members	\$0.00	(\$125.00)	\$0.00	(\$125.00)
Admin Charge-New Members	\$155.00	\$475.00	\$900.00	(\$425.00)
Fines	\$0.00	\$11,462.50	\$15,000.00	(\$3,537.50)
Raffle	\$188.00	\$986.00	\$900.00	\$86.00
Interest	\$33.48	\$134.28	\$450.00	(\$315.72)
Roger Rockas	\$0.00	\$2,663.50	\$0.00	\$2,663.50
Retreat	\$0.00	\$3,901.00	\$3,800.00	\$101.00
Races	\$0.00	\$1,957.00	\$0.00	\$1,957.00
Tailgate	\$0.00	\$520.00	\$720.00	(\$200.00)
Offsite Lunches	\$480.00	\$1,212.00	\$1,350.00	(\$138.00)
Christmas Party	\$0.00	\$2,525.00	\$3,000.00	(\$475.00)
Gift Exchange/Toys for Tots	\$0.00	\$121.00	\$0.00	\$121.00
Auction	\$4,475.00	\$4,575.00	\$0.00	\$4,575.00
Miscellaneous Income	\$793.03	\$1,772.07	\$450.00	\$1,322.07
Total Income	\$6,374.51	\$59,304.35	\$54,570.00	\$4,734.35
EXPENDITURE				
R.I. Dues	\$0.00	\$5,616.75	\$5,800.00	\$183.25
District Dues	\$0.00	\$5,242.94	\$5,800.00	\$557.06
Supplies and Postage	\$111.00	\$1,705.70	\$1,350.00	(\$355.70)
Computer Expenses and Web Site	\$0.00	\$522.00	\$270.00	(\$252.00)
Officer Expense	\$0.00	\$3,997.01	\$950.00	(\$3,047.01)
Terminated Members	\$0.00	\$250.00	\$1,800.00	\$1,550.00
Miscellaneous Expense	\$0.00	\$1,628.78	\$900.00	(\$728.78)
Bank Charges	\$0.00	\$7.72	\$0.00	(\$7.72)
Dist Conf and Assembly	\$0.00	\$0.00	\$250.00	\$250.00
Lunch-Tornino's	\$432.50	\$1,263.00	\$1,575.00	\$312.00
Programs	\$0.00	\$200.00	\$450.00	\$250.00
Speakers	\$0.00	\$0.00	\$1,350.00	\$1,350.00
Demotion Party	\$0.00	\$512.52	\$0.00	(\$512.52)
Bulletin	\$0.00	\$0.00	\$900.00	\$900.00
Banners, Badges, Pins	\$0.00	\$563.82	\$675.00	\$111.18
Hospitality and Fellowship	\$0.00	\$1,915.74	\$3,375.00	\$1,459.26
Blue Book	\$0.00	\$0.00	\$675.00	\$675.00
Rotary Information	\$0.00	\$62.47	\$225.00	\$162.53
Membership	\$0.00	\$0.00	\$450.00	\$450.00
Roger Rockas	\$0.00	\$2,550.00	\$0.00	(\$2,550.00)
Retreat	\$1,469.90	\$5,974.68	\$5,300.00	(\$674.68)
The Races	\$0.00	\$1,934.34	\$0.00	(\$1,934.34)
Mystery Dinner	\$0.00	\$34.62	\$0.00	(\$34.62)
Field Trips	\$793.03	\$793.03	\$0.00	(\$793.03)
Tailgate	\$0.00	\$82.11	\$860.00	\$777.89
Offsite Lunches	\$0.00	\$748.04	\$1,200.00	\$451.96
Christmas Party	\$0.00	\$3,242.81	\$4,000.00	\$757.19
Valentines Day	\$93.43	\$93.43	\$0.00	(\$93.43)
Auction	\$754.79	\$854.79	\$600.00	(\$254.79)
Camp Royal	\$0.00	(\$58.38)	\$0.00	\$58.38
Christmas Food Basket	\$0.00	\$2,000.00	\$0.00	(\$2,000.00)
Community Projects	\$0.00	\$0.00	\$1,125.00	\$1,125.00
Bullard Interact	\$0.00	\$0.00	\$225.00	\$225.00
SJM Interact	\$0.00	\$0.00	\$225.00	\$225.00
Youth Exchange	\$0.00	\$0.00	\$225.00	\$225.00

Rotary Club of Fig Garden

Club Accounts

Income & Expenditure: Comparison to Budget to March 03

Printed 4/15/03

	Current Month	Year to Date	Budget to Date	Variance
Paul Harris	\$0.00	\$0.00	\$450.00	\$450.00
Total Expenditure	\$3,654.65	\$41,737.92	\$41,005.00	(\$732.92)
Excess (Deficit)	\$2,719.86	\$17,566.43	\$13,565.00	\$5,467.27

FIG GARDEN ROTARY CLUB
FOUNDATION
BOARD OF DIRECTORS

*Regular Meeting: 16 April 2003:

-Members Present:

*Directors:

Daniel Bonyhadi
Jamie Franklin
August Hioco
Matt Merzoian
Howard Reed
Steve Rontell
Richard Saroyan

*President:

Eric Fogderude

*Treasurer:

Scott Bristol

*Foundation Treasurer:

Ron Fletcher

*Secretary:

Doug Cords

*Past President:

John Skewes

*President-Elect:

Rod Coburn

The meeting was called to concurrent order by President Eric Fogderude with the Regular Board Meeting of the Fig Garden Rotary Club in the Boardroom of the Stoughton Davidson Accountancy Corporation at 2530 West Shaw Lane, Suite 101, Fresno, California at 7:04 a.m.

*TREASURER'S REPORT:

(Ron Fletcher)

Due to extenuating circumstances, a Treasurer's Report was not presented in the periods covering January and February. Ron presented those reports and covered key income and expenditure items.

Accounts:

*Unrestricted Funds:	\$113,052.
*Permanent Funds:	<u>126,773.</u>
*Totals:	\$239,825.

Ron reviewed items of income and expenses for the month of March. The recap of Auction income and costs reveals an approximate net of \$53,000-54,000.

Next month, an update on Foundation Investments will be presented. It was MSC to approve the Treasurer's Report as presented.

The next Investment Committee Meeting is on May 13, 2003.

*NEXT MEETING: 21 May 2003

*ADJOURNED BY PRESIDENT ERIC FOGDERUDE, CONCURRENT WITH REGULAR MEETING, AT 8:41 a.m.

Respectfully Submitted By Doug Cords, Ph.D., Foundation Secretary.

FIG GARDEN ROTARY FOUNDATION
STATEMENT OF REVENUE, EXPENSES AND CASH BALANCES
JANUARY 31, 2003

	TOTAL FYE	BUDGET	MONTH	MONTH	MONTH	MONTH	MONTH	MONTH	MONTH	MONTH	MONTH	MONTH	MONTH	MONTH	MONTH	MONTH	TOTAL FYE
	02/002	03/003	7/31/02	8/31/02	10/31/02	11/30/02	12/31/02	1/31/03	2/29/03	3/31/03	4/30/03	5/31/03	6/30/03	7/31/03	8/30/03	9/30/03	02/002
REVENUE:																	
AUCTION-2003	\$0	360,000															\$0
AUCTION-2002	67,500			472													67,972
AUCTION-2001	4,150																4,150
5TH AVE FUNDRAISER	0	10,000															0
DONATIONS	12,702																17,505
CLEAR CHNL.COM - JAZZCOO	0	10,000															10,000
EARNINGS - FOUNDATION	1,810	1,500															13,084
EARNINGS - PERM FUND	2,463	10,000															324
CONTRIB - FGR	18,600	0															305
CONTRIB - PERM. FUND	0	5,000															0
UNREAL GAIN-PERM. FUND	(21,484)																(10,664)
	98,519	59,500	5,352	4,003	(1,361)	(379)	3,472	764	19,630	0	0	0	0	0	0	0	32,028
EXPENSES:																	
ADMINISTRATIVE	13	105															13
AUCTION - 2003	1,000	15,000															1,000
AUCTION - 2002	18,089																18,089
AUCTION - 2001	2,086																2,086
5TH AVE FUNDRAISER	0																0
DONATIONS	7,865																7,865
AVENUES OF SERVICE:																	
COMMUNITY SERVICE	53,725	50,000															53,725
VOCATIONAL SERVICE	0	5,000															0
INTERNATIONAL SERVICE	0	5,000															0
VOCATIONAL SCHOLARSHIP	5,000																5,000
R.I. - POLIO PLUS	0	10,000															0
CONTRIB - PERM. FUND	0	5,000															0
	37,811	90,100	0	25	7,700	1,667	0	5,344	3,925	0	0	0	0	0	0	0	16,284
EXCESS OF REVENUES	708	\$6,400	\$5,352	\$3,003	(\$2,046)	\$3,472	(\$2,580)	\$18,165	\$0	\$0	\$0	\$0	\$0	\$0	\$0	\$0	15,762
BEG. CASH BALANCE	234,983																235,691
ENDING CASH BALANCE	\$235,691																\$235,691
RESTRICTED AMOUNTS																	
Paul Harris																	
Paul Harris																	
REMAINING UNDESIGNATED																	
COMM SER FOR 2001-02																	
PLAY IT SAFE																	
HOLIDAY GIFT BASKETS																	
EXPENDITURES ENCUMBERED																	
Paul Harris - 2002 Auction																	
WASHINGTON MUTUAL CHECK	\$7,408																\$32,346
DWR - LIQUID ASSET ACCT	30,928																90,448
PERMANENT FUND	138,655																128,046
	\$235,691																\$235,691
DEFOSITS																	
PAUL HARRIS 260																	
5TH AVE 17505																	
WHEELCHAIR 3350																	
OTHER ENCUMBERED FUNDS																	
INTERNATIONAL SERVICE																	
EXCHANGE STUDENTS-\$2800																	
WHEELCHAIR \$18,000																	
BEG. CASH BALANCE																	
WASHINGTON MUTUAL CHECKING																	
FOUNDATION RESERVE ACCOUNT US\$ PW																	
PERMANENT FUND (ENDOWMENT) US\$ PW																	
TOTAL																	

FIG GARDEN ROTARY FOUNDATION
STATEMENT OF REVENUE, EXPENSES AND CASH BALANCES
FEBRUARY 28, 2003

	TOTAL FYE	BUDGET	MONTH	MONTH	MONTH	MONTH	MONTH	MONTH	MONTH	MONTH	MONTH	MONTH	MONTH	MONTH	TOTAL FYE
	6/30/02	6/30/03	7/3/02	8/3/02	10/3/02	11/3/02	12/3/02	1/3/03	2/28/03	3/31/03	4/30/03	5/31/03	6/30/03	6/30/03	6/30/03
REVENUE:															
AUCTION-2003	\$0	\$60,000													\$0
AUCTION-2002	17,908			472											3,472
AUCTION-2001	4,120														0
5TH AVE FUNDRAISER	0	10,000													0
DONATIONS	12,702			400	3,900	2,126	230	345	16,737						38,242
CLEAR CHNL.COM - JAZZCOO	8,000	10,000	11,054	2,500					4,235						14,725
EARNINGS - FOUNDATION	1,810	1,500	111	88	89	4	3	5							13,584
EARNINGS - PERM. FUND	2,483	11,000	80	75	150										331
CONTRIB - FGR	18,000	0													305
CONTRIB - PERM. FUND	0	5,000													0
UNREAL GAIN-PERM. FUND	(24,454)		(5,433)	935	(5,430)	(2,965)	3,244	416	(1,620)						(1,723)
	38,517	96,500	1,952	4,008	(1,381)	(378)	3,472	781	19,880	21,910	0	0	0	0	59,845
EXPENSES:															
ADMINISTRATIVE	10	100		25											25
AUCTION - 2003	1,000	15,000													0
AUCTION - 2002	14,889			450	317	46									437
AUCTION - 2001	2,636														0
5TH AVE FUNDRAISER	0														0
DONATIONS	7,305						250		10,453						10,478
AVENUES OF SERVICE:															
COMMUNITY SERVICE	53,725	50,000		6,883	1,350		3,014	3,600	14,000						28,557
VOCATIONAL SERVICE	0	5,000													0
INTERNATIONAL SERVICE	0	5,000		690					18,000						18,580
VOCATIONAL SCHOLARSHIP	5,000	0													0
R.J. - POLIO PLUS	10,000	10,000													0
CONTRIB - PERM. FUND	0	5,000													0
	87,811	80,100	0	26	7,703	1,667	0	3,344	9,525	42,453	0	0	0	0	58,717
EXCESS OF REVENUES			\$5,852	\$9,983	(\$9,054)	(\$2,046)	\$3,472	(\$2,680)	\$15,155	(\$30,534)	\$0	\$0	\$0	\$0	(\$4,772)
OVER EXPENSES															
BEG. CASH BALANCE	254,583														254,583
ENDING CASH BALANCE	\$208,991														\$208,991

	REVENUE	EXPENSES	TOTAL
RESTRICTED AMOUNTS			
Paul Harris	0,855		0,855
Paul Harris	88,855		88,855
REMAINING UNDESIGNATED			
COMM SER. FOR 2001-02	4,300		4,300
HOLIDAY GFT BASKETS	2,000		2,000
Belmont Instruct - 2002 Auction	3,480		3,480
WASHINGTON MUTUAL CHECKING	\$13,461		\$13,461
DWR - LIQUID ASSET ACCT	50,506		50,506
PERMANENT FUND	128,853		128,853
FOUNDATOR RESERVE ACCOUNT UBS PW			
PERMANENT FUND (ENDOWMENT) UBS PW			
TOTAL	\$208,991		\$208,991

	REVENUE	EXPENSES	TOTAL
OTHER ENCUMBERED FUNDS			
PAUL HARRIS 680			
INTERNATIONAL SERVICE			
5TH AVE 16237			
WHEELCHAIR 3575			

**FIG GARDEN ROTARY FOUNDATION
CHARITY AUCTION
STATEMENT OF INCOME
April 10, 2003**

REVENUES

Ticket Sales - Paid	\$6,500.00
Ticket Sales A/R (Billed)	\$4,475.00
Ticket Raffle	\$3,010.00
Merchandise Paid	\$49,922.00
Direct Donations	\$5,450.00
<u>TOTAL REVENUE</u>	<u>\$69,357.00</u>

EXPENSES

Facility and Food Cost	\$13,107.70
Decorations	\$349.48
Supplies	\$1,181.80
Printing	
Tickets, Catalogs, Bid Sheets, gift certificates	\$350.87
Merchant Discount/Credit Cards	\$1,176.99
Sound System	\$50.00
Raffle	\$0.00
Lunch & Other Foods	\$363.24
Flowers (Carnations)	\$272.28
Other Misc	
San Joaquin Memorial Interact	\$605.00
Bullard Interact	\$202.00
<u>TOTAL EXPENSES</u>	<u>\$17,659.36</u>

NET INCOME **\$51,697.64**

Prepared by Ron Fletcher, Foundation Treasurer

10-Apr-03

FIG GARDEN ROTARY FOUNDATION
St. Patrick's Day Charity Auction
Comparative Statement of Income
 As of April 10, 2003

	2003	2002	2001	2000	1999	1998	1997	1996	1995	1994	1993	1992	1991
	Auction	Auction	Auction	Auction	Auction	Auction	Auction	Auction	Auction	Auction	Auction	Auction	Auction
Revenue													
Ticket Sales - Paid	\$6,500	\$7,315	\$4,500	\$5,000	\$3,400	\$4,230	\$2,198	\$7,130	\$7,102	\$7,130	\$7,740	\$5,713	\$7,573
- AVR	4,475	5,350	4,460	4,500	2,880	0	1,206	0	560	-	-	-	-
	10,975	12,665	8,960	9,500	6,280	4,230	3,404	7,130	7,662	7,130	7,740	5,713	7,573
Ticket Raffle	3,010	3,025	3,020	2,828									
Merchandise - Paid	49,922	49,807	47,015	44,462	36,600	42,816	42,355	38,169	41,808	43,860	48,248	46,425	39,375
- AVR	0	0	0	780	850	0	0	0	1,237	-	-	-	-
	49,922	49,807	47,015	45,242	37,450	42,816	42,355	38,169	43,045	43,860	48,248	46,425	39,375
Donations	5,450	3,725	2,915	6,011				200	200				
Bedroom Set - \$50/member	0	5,500	0	0	0	0	0	0	0				
Total Revenue	69,357	74,722	61,910	63,581	43,730	47,046	45,759	45,299	50,707	50,990	55,988	52,138	46,948
Expenses													
Facility and Food Cost	13,108	12,658	11,044	10,288	6,724	9,914	8,302	8,490	9,495	8,260	7,203	7,577	10,028
Entertainment	0	0	100	100	200	0	0	750	300	250	275	-	250
Auctioneer	0	0	0	0	0	250	250	350	250	250	250	-	-
Decorations	350	332	0	0	804	1,198	845	847	1,392	1,376	653	450	1,353
Supplies	1,182	932	710	264	223	141	285	502	1,193	151	926	1,163	692
Printing - Tickets	351	0	288	0	261	0	308	312	302	302	338	307	218
- Catalogs	0	0	0	0	1,349	1,389	1,322	1,272	1,454	1,325	1,299	377	1,583
- Bid Sheets & Gift Cards	0	0	0	90	0	0	376	409	356	-	300	-	264
Merchant Disc. (Credit Cards)	1,177	816	734	767	687	672	799	580	646	664	636	569	-
Sound System	50	0	0	0	0	0	183	-	646	105	146	-	-
Raffle	0	0	201	0	0	70	0	0	50	15	50	-	-
Lunch & Other food	353	55	342	209	405	328	205	274	343	456	128	174	334
Flowers (Carnations)	272	0	0	0	0	0	-	-	-	79	215	108	-
In-Put Personnel	0	0	0	0	5	0	0	0	-	-	-	-	-
Batteries - Lights for silent auction	0	0	347	39	0	0	0	73	-	-	-	-	-
Other Misc - inc- Interact Clubs	807	730	175	105	1,681	1,257	0	15	71	186	86	84	400
Total Expenses	17,650	15,513	13,941	11,862	12,339	15,219	12,875	13,874	15,862	13,419	12,505	10,914	15,300
Before Car Raffle	51,697	59,209	47,969	51,719	31,391	31,827	32,884	31,425	34,855	37,571	43,483	41,224	31,648
Car Raffle Net Proceeds	0	0	0	0	880	26,392	12,910	-	-	-	-	8,796	13,525
Net Income	\$51,697	\$59,209	\$47,969	\$51,719	\$32,271	\$58,219	\$45,794	\$31,425	\$34,855	\$37,571	\$43,483	\$50,020	\$45,173

Fig Garden Rotary Endowment Account

Asset Allocation	
US Large Co. Equity	\$ 22,642.50
US Med/Sm Co. Equity	\$ 22,671.63
Balanced	\$ -
Int'l Equity	\$ 13,451.36
Int'l Fixed Income	\$ -
US Fixed Income	\$ 51,635.90
Cash/Money Market	\$ 16,372.06
	\$ 128,773.45
	100.00%

Account Allocation

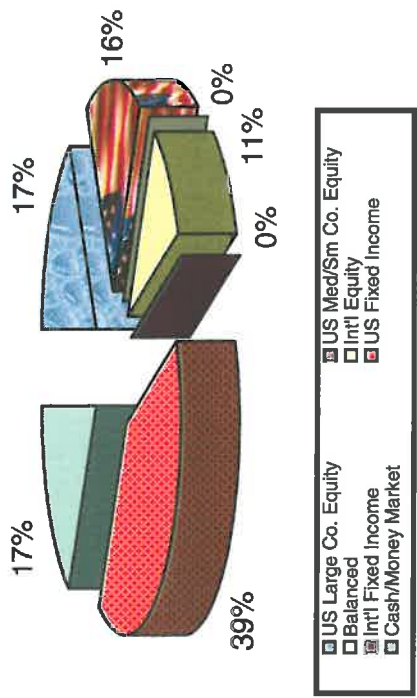

- US Large Co. Equity
- Balanced
- Int'l Equity
- Int'l Fixed Income
- Cash/Money Market
- US Med/Sm Co. Equity
- Int'l Fixed Income

Investment Holdings

as of 3/31/03

	Cost Basis	Value Jan 01, 2003	Value 3/31/2003	% Chg from 1/1/2003
<u>US Large Co. Equity:</u>				
Income Fund of America	\$ 11,107.99	\$ 10,417.91	\$ 11,164.02	7.16%
Pimco Value Fund	\$ 11,979.65	\$ 11,195.52	\$ 11,478.48	2.53%
<u>US Med/Sm Co. Equity:</u>				
Liberty Acorn Fund	\$ 11,094.31	\$ 10,415.86	\$ 11,152.68	7.07%
Pimco Small Cap Value	\$ 11,990.29	\$ 11,037.68	\$ 11,518.95	4.36%
<u>Balanced:</u>				
<u>Int'l Equity</u>				
Templeton Foreign	\$ 14,730.49	\$ 13,777.98	\$ 13,451.36	-2.37%
<u>US & Int'l Fixed Income:</u>				
CD Independent Bank 2% due 10/23/03 *	\$ 12,973.87	\$ 12,916.93	\$ 12,967.24	0.39%
CD Discover Bank 2.5% due 11/08/04 *	\$ 12,000.00	\$ 12,043.08	\$ 12,094.32	0.43%
CD Key Bank & Trust 3.1% due 11/08/05 *	\$ 13,000.00	\$ 13,123.76	\$ 13,245.05	0.92%
CD Pan American Bank 3.65% due 10/30/06 *	\$ 12,930.84	\$ 13,185.38	\$ 13,329.29	1.09%
<u>Cash/Money Market:</u>				
Money Market	\$ 16,372.06	\$ 21,449.98	\$ 16,372.06	
TOTAL PORTFOLIO	\$ 128,179.50	\$ 129,564.08	\$ 126,773.45	-2.15%
Foundation Account Value				\$ 75,556.13



Paul Sahota - Financial Advisor

FIG GARDEN ROTARY CLUB

BOARD OF DIRECTORS

SPECIAL MEETING: 13 June 2003 -

Due notice was sent to Directors via fax and mail. The following were present:

Daniel Bonyhadi	August Hioco
Scott Bristol	Matt Merzoian
Doug Cords	Steve Rontell
Ron Fletcher	Richard Saroyan
Jamie Franklin	Dave Stepp

President Eric Fogderude established a quorum and called the meeting to order at 1:35 p.m. at the TorNino's Restaurant, Fresno, California.

Order Of Business:

It was MSC to declare the Club "Dark" on Friday, 4 July 2003. Secretary to notify TorNino's and provide a Make-Up Sheet for Visitors.

NEW MEMBER PROPOSAL:

Ted Fleener

General Manager,
Fresno Mitsubishi

Proposors: John Heberger and Mary Lou Gunn

Membership has approved.

Proposed Classification: Automotive Industry: Sales Management

It was MSC to approve the Nomination. Secretary to forward immediately to Rotary Information.

Director Dave Stepp polled the Board regarding the feasibility of a Field Trip (courtesy of COG Tony Carr) to the Fresno Heart Hospital on 1 August. It was enthusiastically supported. Dave to notify the Program Chair, AVENUES Bulletin and Judy Perkins at TorNino's.

The meeting was adjourned at 1:40 p.m.

Respectfully Submitted By Doug Cords, Ph.D., Club Secretary

FIG GARDEN ROTARY CLUB

BOARD OF DIRECTORS

*Regular Meeting - 21 May 2003:

*Members Present:

*Directors:

Daniel Bonyhadi
Jamie Franklin
August Hioco
Matt Merzoian
Howard Reed
Steve Rontell
Richard Saroyan
David Stepp

*Foundation Treasurer:

Ron Fletcher

*Past President:

John Skewes

*President-Elect:

Rod Coburn

*Others Present:

Steve Wilson
Jay Roll
Mike Gerardi
Tony Carr

*President:

Eric Fogderude

*Secretary:

Doug Cords

*Treasurer:

Scott Bristol

**Special Guest: **

Paul Sahota, UBS
Paine Webber

The meeting was called to order by President Eric Fogderude at 7:03 a.m. in the Boardroom of the Stoughton Davidson Accountancy Corporation at 2530 West Shaw Lane, Fresno, California 93711 (Suite # 101).

*INITIAL BUSINESS:

President Eric Fogderude re-nominated Director David Stepp to the Board, a result of business/travel pressures necessitating his missing three Board meetings, It was MSC to approve the re-nomination.

*CONSENT ITEMS:

*Minutes Of The 16 April 2003 Regular Board Meeting		
*Attendance For Month Of April, 2003	=	76%
*Membership As Of 1 May 2003	=	104

It was MSC to approve the Consent Items as presented.

*TREASURER'S REPORT:

(Scott Bristol)

Scott reviewed Current Assets, as follows:

*Cal Fed:	\$12,149.
*Morgan Stanley	26,636.
*Members' Accounts:	22,316.
*Playland Note:	5,000.
*Totals:	<u>\$66,101.</u>

*TREASURER'S REPORT, Continued:

The only major Current Liability is the Woodward Park Bench Project, in the amount of \$1,500.; this was a carryover from President John Skewes' year, to be used for a bench to honor deceased Club members. President-Elect Coburn would like to retain this line item for use as "seed money" for next year, as a Platform Plank of the Rotary year.

Scott then reviewed with the Board Income and Expenses, both Year To Date Compared To Budget And Last Year and Month-Ended.

It was MSC to approve the Treasurer's Report as presented.

*SECRETARY'S REPORT: (Doug Cords)

Per last month's Board Meeting, the Club is entitled to voting delegates totaling two at the Rotary International Convention. President Eric invited members to apply from the Podium at a recent meeting, and Avenues carried a like notice. No one came forward to make the request. It was MSC to nominate Dr. Rod Coburn as the Proxy for the second vote. Secretary to complete the paperwork and deliver to President-Elect Rod.

Attendance Issues: as is usual during the end of any six-month attendance period, several members are "on the bubble" with regard to either the 60% attendance requirement overall or the 30% home club rule. Secretary contacts personally each member, encouraging make-ups to avoid problems later on. It is interesting to note that several members who have problems with attendance also have financial issues with the Club.

The resignation of Wink Chase, who has relocated to Southern California, has been received and will be forwarded to Rotary International.

The Secretary circulated a recent Fortune magazine article lauding Rotary's "Polio Plus" program.

COG Fernando Morales has been terminated, due to unresolved attendance issues and an apparent disinterest in remaining in Fig Garden Rotary Club.

New Member Pipeline: Darryl Booth, sponsored by August Hioco and Sasan Rahmatian, was published on 15 May. the 7-Day Notice is now in effect. Darryl works at Decade Software. Pending no communications regarding the notice period, he will be inducted into the club on 30 May.

There are no new member proposals this month.

*PRESIDENT-ELECT'S REPORT: (Rod Coburn)

Rod verified that final figures for the Auction disclose that the approximate net is in the low \$50,000's.

Rod and President Eric attended the District Conference, wherein the Club was recognized for a Polio Plus Award.

Bullard High School has noted it will accept a total of only two Rotary Exchange Students for the coming year, a possible problem with our sponsorship. Rod will stay on top of this. The CV's of the Inbound and Outbound Exchange Student nominees were circulated for review.

*PAST PRESIDENT'S REPORT: (John Skewes)

John commended President Eric for a job well done. The Board expressed its sincere thanks to John for this year's leadership and wise counsel as a former President.

*PRESIDENT'S TIME: (Eric Fogderude)

In the July Board meeting, Eric will present an update of the computer hardware/equipment status and recommendations for utilization and storage.

It was MSC to utilize \$10,000. from "The Night On Fifth Avenue" fundraiser, per previous agreement, as a partial disposition of funds generated. This funding will go to Paul Harris Funding and will put the Club ahead of its commitments for this Rotary year.

The theme for this year's Demotion Party will be "25th Anniversary Of Fig Garden Rotary" Club. The Sanger Club is celebrating this year its 50th anniversary; Director August Hioco, who will attend the Club's fete, will pass along our club's congratulations for five decades of service.

Eric concluded his report by offering his sincere appreciation to each Board Member for contributions made during this year. At the 20 June meeting, he asked each to attend, to receive Club laudits and special recognition for jobs well accomplished.

*AVENUES OF SERVICE:

-Club Service: (Daniel Bonyhadi and August Hioco)

The successful Mystery Dinner, chaired by Steve Wilson, was held on 16 May. Harvey Armas is handling details and planning for the upcoming Demotion Party.

The Club enjoyed 15 events total so far this year.

-Community Service: (Richard Saroyan and Steve Rontell)

It was MSC to allocate the sum of \$3,800. for the "Unfolding Hearts" program for terminally ill children, for the purchase/assembling of educational kits.

It was MSC to allocate the sum of \$1,000. for the Duncan Polytechnic High School's construction management program, to purchase a unit of framing lumber.

It was MSC to target as the Club's "Centennial Project" the refurbishing of selected elements of the Theater on the campus of Bullard High School. President-Elect Rod noted this will provide naming rights, an opportunity to involve Interact members, a hands-on opportunity and provide a huge community service. The program in its entirety perhaps may take two years.

Richard and Steve expressed appreciation to the diligent and dedicated members who volunteered for the Community Service Committee this year. Steve also thanked the Saroyans for their special hospitality in their home, at each month's meeting.

-Vocational Service:

(Dave Stepp and Matt Merzoian)

The Directors noted that the Scholarship Program at San Joaquin Memorial High School is completed, with students recently visiting the Club to be awarded their funding.

The students from Bullard High School will come to the Club on 30 May.

(Editorial Note: in contrast to previous Board discussions regarding the (-) with the practice, checks for students are still made payable to the individual rather than to the school to be attended)

Camp Royal will again be staffed for a dinner and volunteers were solicited. Jim Gibbs in handling the selection of attendees through Bullard High School.

-International Service:

(Jamie Franklin and Howard Reed)

The contact for the Wheelchair Project in Quito, Ecuador is doing a superb job thus far, working to handle logistics between the Wheelchair Foundation, the Club and the manufacturing entity in China. October is the hoped-for delivery timeframe.

*OLD BUSINESS:

Treasurer Scott Bristol reviewed the "Aged Trial Balance" of member receivables, especially those more than 120 days in arrears. President Eric's letters have accomplished some payments. Several members have accrued very large past-due balances and this situation must be addressed.

*NEW BUSINESS:

Jamie Franklin noted that the next Auction will be again held at Casablanca, on 27 March 2004. He will be accepting Auction Chair Nominations.

Dr. Rod Coburn intends to host a Board Retreat in June, after his return from the RI Convention.

*ADJOURNMENT: President Eric adjourned the meeting at 8:31 a.m.

*NEXT MEETING: 16 July 2003 At Stoughton Davidson Accountancy Corporation

(Note: No June Board Meeting/Per Prior Board Motion)

RESPECTFULLY SUBMITTED BY DOUG CORDS, Ph.D., CLUB SECRETARY.

Rotary Club of Fig Garden

Club Accounts

Balance sheet for period ending 30 April 03

Printed 5/16/03

ACCUMULATED FUNDS

Club Funds

Balance at beginning of year	\$56,352.89
Excess (Deficit) for period	\$8,674.56
Balance to Date	\$65,027.45

TOTAL FUNDS	<u>\$65,027.45</u>
--------------------	--------------------

Represented by:

ASSETS

Checking Account-Cal Fed	\$12,149.01
Morgan Stanley Dean Witter	\$26,636.50
Member's Current Accounts	\$22,316.94
Note Rec - Playland	<u>\$5,000.00</u>
Total Assets	<u>\$66,102.45</u>

LIABILITIES

PHF Clearing	(\$425.00)
Woodward Park Bench Project	<u>\$1,500.00</u>
Total Liabilities	<u>\$1,075.00</u>

NET ASSETS	<u>\$65,027.45</u>
-------------------	--------------------

Rotary Club of Fig Garden

Club Accounts

Income & Expenditure: Current Month & Year to Date to April 03

Printed 5/16/03

	Current Month	Year to Date
INCOME		
Member Dues	\$0.00	\$27,125.00
Terminated Members	\$0.00	(\$125.00)
Admin Charge-New Members	\$0.00	\$475.00
Fines	\$0.00	\$17,093.75
Raffle	\$0.00	\$986.00
Interest	\$11.41	\$145.69
Roger Rockas	\$0.00	\$2,663.50
Retreat	\$0.00	\$3,901.00
Races	\$0.00	\$1,957.00
Tailgate	\$0.00	\$520.00
Offsite Lunches	\$0.00	\$1,212.00
Christmas Party	\$0.00	\$2,525.00
Gift Exchange/Toys for Tots	\$0.00	\$121.00
Auction	(\$50.00)	\$4,525.00
Miscellaneous Income	\$0.00	\$1,934.57
Total Income	(\$38.59)	\$65,059.51
EXPENDITURE		
R.I. Dues	\$0.00	\$5,616.75
District Dues	\$0.00	\$5,242.94
Supplies and Postage	\$0.00	\$1,705.70
Computer Expenses and Web Site	\$0.00	\$522.00
Officer Expense	\$0.00	\$3,997.01
Terminated Members	\$0.00	\$250.00
Miscellaneous Expense	\$0.00	\$1,628.78
Bank Charges	\$5.40	\$13.12
Lunch-Tornino's	\$0.00	\$1,263.00
FGR Foundation	\$10,000.00	\$10,000.00
Programs	\$0.00	\$200.00
Demotion Party	\$0.00	\$512.52
Banners, Badges, Pins	\$0.00	\$563.82
Hospitality and Fellowship	\$1,790.13	\$3,705.87
Blue Book	\$1,821.52	\$1,821.52
Rotary Information	\$0.00	\$62.47
Roger Rockas	\$0.00	\$2,550.00
Retreat	\$0.00	\$5,974.68
The Races	\$0.00	\$1,934.34
Mystery Dinner	\$0.00	\$34.62
Field Trips	\$579.98	\$1,373.01
Tailgate	\$0.00	\$82.11
Offsite Lunches	\$0.00	\$748.04
Christmas Party	\$0.00	\$3,242.81
Valentines Day	\$0.00	\$93.43
Auction	\$0.00	\$854.79
Camp Royal	\$0.00	(\$58.38)
Christmas Food Basket	\$0.00	\$2,000.00
Paul Harris	\$450.00	\$450.00
Total Expenditure	\$14,647.03	\$56,384.95
Excess (Deficit)	(\$14,685.62)	\$8,674.56

Rotary Club of Fig Garden

Club Accounts

Income & Expenditure: Current Year vs Previous Year to April 03

Printed 5/16/03

	Month		Year to Date	
	Current Year	Previous Year	Current Year	Previous Year
INCOME				
Member Dues	\$0.00	\$0.00	\$27,125.00	\$27,557.50
Terminated Members	\$0.00	\$0.00	(\$125.00)	\$0.00
Admin Charge-New Members	\$0.00	\$0.00	\$475.00	\$720.00
Fines	\$0.00	\$0.00	\$17,093.75	\$15,644.75
Raffle	\$0.00	\$0.00	\$986.00	\$1,243.00
Interest	\$11.41	\$0.00	\$145.69	\$295.60
Demotion Party	\$0.00	\$0.00	\$0.00	\$60.00
Roger Rockas	\$0.00	\$0.00	\$2,663.50	\$0.00
Retreat	\$0.00	\$0.00	\$3,901.00	\$3,575.00
Races	\$0.00	\$0.00	\$1,957.00	\$2,188.00
Tailgate	\$0.00	\$0.00	\$520.00	\$700.00
Offsite Lunches	\$0.00	\$375.00	\$1,212.00	\$1,176.00
Christmas Party	\$0.00	\$0.00	\$2,525.00	\$3,600.00
Gift Exchange/Toys for Tots	\$0.00	\$0.00	\$121.00	\$0.00
Auction	(\$50.00)	\$0.00	\$4,525.00	\$6,235.00
Miscellaneous Income	\$0.00	\$2,100.00	\$1,934.57	\$3,819.96
Community Projects	\$0.00	\$0.00	\$0.00	\$2,500.00
Wheelchair Project	\$0.00	\$0.00	\$0.00	\$140.00
Paul Harris	\$0.00	\$0.00	\$0.00	\$315.00
Total Income	(\$38.59)	\$2,475.00	\$65,059.51	\$69,769.81
EXPENDITURE				
R.I. Dues	\$0.00	\$0.00	\$5,616.75	\$5,355.04
District Dues	\$0.00	\$0.00	\$5,242.94	\$5,647.68
Supplies and Postage	\$0.00	\$0.00	\$1,705.70	\$1,140.56
Computer Expenses and Web Site	\$0.00	\$0.00	\$522.00	\$0.00
Officer Expense	\$0.00	\$1,200.00	\$3,997.01	\$1,808.96
Terminated Members	\$0.00	\$0.00	\$250.00	\$2,530.00
Miscellaneous Expense	\$0.00	\$112.19	\$1,628.78	\$1,001.19
Bank Charges	\$5.40	\$0.00	\$13.12	\$7.48
Dist Conf and Assembly	\$0.00	\$100.00	\$0.00	\$100.00
Lunch-Tornino's	\$0.00	\$0.00	\$1,263.00	\$1,768.50
FGR Foundation	\$10,000.00	\$0.00	\$10,000.00	\$5,000.00
Programs	\$0.00	\$0.00	\$200.00	\$86.53
Demotion Party	\$0.00	\$0.00	\$512.52	\$329.41
Bulletin	\$0.00	\$0.00	\$0.00	\$359.85
Banners, Badges, Pins	\$0.00	\$0.00	\$563.82	\$779.02
Hospitality and Fellowship	\$1,790.13	\$130.00	\$3,705.87	\$2,265.55
Blue Book	\$1,821.52	\$0.00	\$1,821.52	\$987.07
Rotary Information	\$0.00	\$0.00	\$62.47	\$182.25
Roger Rockas	\$0.00	\$0.00	\$2,550.00	\$0.00
Retreat	\$0.00	\$0.00	\$5,974.68	\$4,660.47
The Races	\$0.00	\$0.00	\$1,934.34	\$2,080.22
Mystery Dinner	\$0.00	\$0.00	\$34.62	\$0.00
Field Trips	\$579.98	\$0.00	\$1,373.01	\$0.00
Tailgate	\$0.00	\$0.00	\$82.11	\$823.76
Offsite Lunches	\$0.00	\$356.00	\$748.04	\$1,195.87
Christmas Party	\$0.00	\$0.00	\$3,242.81	\$4,981.19
Valentines Day	\$0.00	\$0.00	\$93.43	\$151.45
Auction	\$0.00	\$0.00	\$854.79	\$4,478.26
Camp Royal	\$0.00	\$0.00	(\$58.38)	(\$66.83)
Christmas Food Basket	\$0.00	\$0.00	\$2,000.00	\$0.00
Community Projects	\$0.00	\$0.00	\$0.00	\$5,175.00

Rotary Club of Fig Garden

Club Accounts

Income & Expenditure: CurrentYear vs Previous Year to April 03

Printed 5/16/03

	Month		Year to Date	
	Current Year	Previous Year	Current Year	Previous Year
Bullard Interact	\$0.00	\$500.00	\$0.00	\$500.00
SJM Interact	\$0.00	\$500.00	\$0.00	\$500.00
Youth Exchange	\$0.00	\$0.00	\$0.00	\$53.76
Paul Harris	\$450.00	\$0.00	\$450.00	\$1,500.00
Total Expenditure	\$14,647.03	\$2,898.19	\$56,384.95	\$55,382.24
Excess (Deficit)	(\$14,685.62)	(\$423.19)	\$8,674.56	\$14,387.57

Rotary Club of Fig Garden

Club Accounts

Income & Expenditure: Comparison to Budget to April 03

Printed 5/16/03

	Current Month	Year to Date	Budget to Date	Variance
INCOME				
Member Dues	\$0.00	\$27,125.00	\$28,000.00	(\$875.00)
Terminated Members	\$0.00	(\$125.00)	\$0.00	(\$125.00)
Admin Charge-New Members	\$0.00	\$475.00	\$1,000.00	(\$525.00)
Fines	\$0.00	\$17,093.75	\$15,000.00	\$2,093.75
Raffle	\$0.00	\$986.00	\$1,000.00	(\$14.00)
Interest	\$11.41	\$145.69	\$500.00	(\$354.31)
Roger Rockas	\$0.00	\$2,663.50	\$0.00	\$2,663.50
Retreat	\$0.00	\$3,901.00	\$3,800.00	\$101.00
Races	\$0.00	\$1,957.00	\$0.00	\$1,957.00
Tailgate	\$0.00	\$520.00	\$720.00	(\$200.00)
Offsite Lunches	\$0.00	\$1,212.00	\$1,500.00	(\$288.00)
Christmas Party	\$0.00	\$2,525.00	\$3,000.00	(\$475.00)
Gift Exchange/Toys for Tots	\$0.00	\$121.00	\$0.00	\$121.00
Auction	(\$50.00)	\$4,525.00	\$0.00	\$4,525.00
Miscellaneous Income	\$0.00	\$1,934.57	\$500.00	\$1,434.57
Total Income	(\$38.59)	\$65,059.51	\$55,020.00	\$10,039.51
EXPENDITURE				
R.I. Dues	\$0.00	\$5,616.75	\$5,800.00	\$183.25
District Dues	\$0.00	\$5,242.94	\$5,800.00	\$557.06
Supplies and Postage	\$0.00	\$1,705.70	\$1,500.00	(\$205.70)
Computer Expenses and Web Site	\$0.00	\$522.00	\$300.00	(\$222.00)
Officer Expense	\$0.00	\$3,997.01	\$2,650.00	(\$1,347.01)
Terminated Members	\$0.00	\$250.00	\$1,800.00	\$1,550.00
Miscellaneous Expense	\$0.00	\$1,628.78	\$1,000.00	(\$628.78)
Bank Charges	\$5.40	\$13.12	\$0.00	(\$13.12)
Dist Conf and Assembly	\$0.00	\$0.00	\$250.00	\$250.00
Lunch-Tornino's	\$0.00	\$1,263.00	\$1,750.00	\$487.00
FGR Foundation	\$10,000.00	\$10,000.00	\$0.00	(\$10,000.00)
Programs	\$0.00	\$200.00	\$500.00	\$300.00
Speakers	\$0.00	\$0.00	\$1,500.00	\$1,500.00
Demotion Party	\$0.00	\$512.52	\$0.00	(\$512.52)
Bulletin	\$0.00	\$0.00	\$1,000.00	\$1,000.00
Banners, Badges, Pins	\$0.00	\$563.82	\$750.00	\$186.18
Hospitality and Fellowship	\$1,790.13	\$3,705.87	\$3,750.00	\$44.13
Blue Book	\$1,821.52	\$1,821.52	\$750.00	(\$1,071.52)
Rotary Information	\$0.00	\$62.47	\$250.00	\$187.53
Membership	\$0.00	\$0.00	\$500.00	\$500.00
Roger Rockas	\$0.00	\$2,550.00	\$0.00	(\$2,550.00)
Retreat	\$0.00	\$5,974.68	\$5,300.00	(\$674.68)
The Races	\$0.00	\$1,934.34	\$0.00	(\$1,934.34)
Mystery Dinner	\$0.00	\$34.62	\$0.00	(\$34.62)
Field Trips	\$579.98	\$1,373.01	\$0.00	(\$1,373.01)
Tailgate	\$0.00	\$82.11	\$860.00	\$777.89
Offsite Lunches	\$0.00	\$748.04	\$1,800.00	\$1,051.96
Christmas Party	\$0.00	\$3,242.81	\$4,000.00	\$757.19
Valentines Day	\$0.00	\$93.43	\$0.00	(\$93.43)
Auction	\$0.00	\$854.79	\$600.00	(\$254.79)
Camp Royal	\$0.00	(\$58.38)	\$0.00	\$58.38
Christmas Food Basket	\$0.00	\$2,000.00	\$0.00	(\$2,000.00)
Community Projects	\$0.00	\$0.00	\$1,250.00	\$1,250.00
Bullard Interact	\$0.00	\$0.00	\$250.00	\$250.00
SJM Interact	\$0.00	\$0.00	\$250.00	\$250.00

Rotary Club of Fig Garden

Club Accounts

Income & Expenditure: Comparison to Budget to April 03

Printed 5/16/03

	Current Month	Year to Date	Budget to Date	Variance
Youth Exchange	\$0.00	\$0.00	\$250.00	\$250.00
Paul Harris	\$450.00	\$450.00	\$500.00	\$50.00
Group Study Exchange	\$0.00	\$0.00	\$500.00	\$500.00
Total Expenditure	\$14,647.03	\$56,384.95	\$45,410.00	(\$10,974.95)
Excess (Deficit)	(\$14,685.62)	\$8,674.56	\$9,610.00	\$21,014.46

FIG GARDEN ROTARY CLUB

FOUNDATION
BOARD OF DIRECTORS

*Regular Meeting - 21 May 2003:

*Members Present:

*Directors:

Daniel Bonyhadi
Jamie Franklin
August Hioco
Matt Merzoian
Howard Reed
Steve Rontell
Richard Saroyan
David Stepp

*President:

Eric Fogderude

*Treasurer:

Scott Bristol

*Foundation Treasurer:

Ron Fletcher

*Past President:

John Skewes

*President-Elect:

Rod Coburn

*Secretary:

Doug Cords

**Special Guest: **

Paul Sahota, UBS
Paine Webber

*Others Present:

Steve Wilson
Jay Roll
Mike Gerardi
Tony Carr

The meeting was called to concurrent order by President Eric Fogderude with the Regular Board Meeting of the Fig Garden Rotary Club in the Boardroom of the Stoughton Davidson Accountancy Corporation at 2530 West Shaw Lane, Suite 101, Fresno, California at 7:03 a.m.

*TREASURER'S REPORT: (Ron Fletcher)

Ron furnished the Board with Income and Expense items for April, with Income totaling \$24,928 and Expenses totaling \$15,077. Income items emanated from Auction, Wheelchair Project, Paul Harris Foundation and a generous contribution from Daniel and Lorna Bonyhadi through the Foundation For Seniors. Major expenses were for Polio Plus and Community Service.

Accounts:

*Unrestricted Funds: \$122,961.
*Permanent Funds: 141,251.
*Totals: \$264,212.

Paul Sahota from UBS Paine Webber reviewed funding sources, as three individual brokerage accounts were combined for the current program. He works regularly with the 7-member Investment Committee, per our pre-set guidelines. Paul reviewed the Investment Holdings and changes in recent months. Returns average 2.81% since the program commenced.

President Eric lauded Past Foundation Treasurer Tripp Pound for his extraordinary past service on Investments. Paul shared with the Board his appreciation for the quality work performed by the Investment Committee.

It was MSC to approve the Treasurer's Report as presented.

*ADJOURNMENT: Concurrent With The Regular Board Meeting, Adjourned At 8:30 a.m. by President Eric Fogderude.

*NEXT MEETING: 16 July 2003 at Stoughton Davidson Accountancy Corporation

RESPECTFULLY SUBMITTED BY DOUG CORDS, Ph.D., FOUNDATION SECRETARY.

FIG GARDEN ROTARY FOUNDATION
STATEMENT OF REVENUE, EXPENSES AND CASH BALANCES
APRIL 30, 2003

	TOTAL FYE	BUDGET	7/31/02	8/31/02	9/30/02	10/31/02	11/30/02	12/31/02	1/31/03	2/28/03	3/31/03	4/30/03	5/31/03	MONTH	TOTAL FYE
	6/30/02	6/30/03												6/30/03	6/30/03
REVENUE:															
AUCTION- 2003	\$0	\$60,000									43330	22643		\$65,973	
AUCTION- 2002	67,908			472										\$472	
AUCTION- 2001	4,120													0	
5TH AVE FUNDRAISER	0	10,000												36,242	
DONATIONS	12,702			400	3,800	2,125	220	345	17,505	18,737	1,105	2,286		18,116	
CLEAR CHNL COM - JAZZ/COO	6,000		11,094	2,500					3,600	4,235				13,594	
EARNINGS - FOUNDATION	1,810	1,500	111	98	98	4	4	3	5	7	8	10		349	
EARNINGS - PERM. FUND	2,463	10,000	80	75	150									305	
CONTRIB - FGR	18,000	0												0	
CONTRIB - PERM. FUND	0	5,000	(5,433)	935	(5,430)	(2,980)	3,248	416	(1,420)	(1,060)	(128)	4,525		10,000	
UNREAL GAIN-PERM. FUND	(24,484)													(7,327)	
	88,519	96,500	5,852	4,008	(1,381)	(379)	3,472	764	19,690	21,919	985	16,821	0	137,724	
EXPENSES:															
ADMINISTRATIVE	16	100		25										\$25	
AUCTION - 2003	1,000	15,000			450	317	80				16,725	927		17,652	
AUCTION - 2002	18,669										480			1,327	
AUCTION - 2001	2,096													0	
5TH AVE FUNDRAISER	0													10,989	
DONATIONS	7,305						250			25	511			250	
AVENUES OF SERVICE:														0	
COMMUNITY SERVICE	53,725	50,000		6,693	1,350	3,014	3,500	14,000	17,693	5,200				51,450	
VOCATIONAL SERVICE	0	5,000		560						18,000	0			18,560	
INTERNATIONAL SERVICE	0	5,000												0	
VOCATIONAL SCHOLARSHIP	5,000	10,000												8,950	
R.J. - POLIO PLUS	0	5,000												0	
CONTRIB - PERM. FUND	0													0	
	87,811	90,100	0	25	7,703	1,667	0	3,344	3,525	42,453	35,409	15,077	0	109,203	
EXCESS OF REVENUES	708	\$6,400	\$5,852	\$3,983	(\$9,084)	(\$2,046)	\$3,472	(\$2,560)	\$16,165	(\$20,534)	(\$34,424)	\$1,744	\$0	\$0	
OVER EXPENSES															
BEG. CASH BALANCE	234,983													235,691	
ENDING CASH BALANCE	\$235,691													\$264,212	
RESTRICTED AMOUNTS															
Paul Harris				1,100											
				\$1,100											
EXPENDITURES ENCUMBERED															
WASHINGTON MUTUAL CHECKING	\$7,108													\$47,358	
DWR - LIQUID ASSET ACCT	89,928													75,603	
PERMANENT FUND	138,655													141,251	
	\$235,691													\$264,212	
** REMAINING UNDESIGNATED															
COMM SER FOR 2001-02									2000						
HOLIDAY GIFT BASKETS															
WASHINGTON MUTUAL CHECKING															
FOUNDATION RESERVE ACCOUNT															
PERMANENT FUND															
OTHER ENCUMBERED FUNDS															
INTERNATIONAL SERVICE															
EXCHANGE STUDENTS-\$2600															

DEPOSITS
SEE PG.2

Fig Garden Rotary Foundation

April 2003

* Summary of Deposits:

Checking Interest — \$10⁰⁰
Wheel chair Project — 450⁰⁰
Paul Harris Donations — 915⁰⁰
Auction 2003 — 22,643⁰⁰
Foundation for Seniors (Alzheimers) — 920⁵²

Total — \$24,928⁵²

* Summary of Expenses:

The Rotary Foundation (Paul Harris) — \$ 8,950⁰⁰
Crime Stoppers — 12,000⁰⁰
Marjorie Mason Center — 2,500⁰⁰
Leukemia & Lymphoma Society — 1,500⁰⁰
Auction 2003 — 927⁰⁰

Total — \$15,077

UBS PAINWEBBER INC.
 FIG GARDEN FINANCIAL CENTER
 5200 NO. PALM, SUITE 101
 FRESNO, CA 93704-7669
 PZ1A004542-X6 - 0403 - FE - 0

Your Financial Advisor
 SAHOTA, GURKIRPAL (PAUL)
 559-226-2800/800-423-8797

**UBS PaineWebberSM
 Business Services Account BSA[®]**

PZ1A004542-X6

Account Number: FE 31093 20

April 2003

This month at a glance

Value on March 31	\$	75,558.13
Value on April 30	\$	75,603.19
Money fund and other sweep option balance in 04/30 value	\$	75,603.19

00000780

FIG GARDEN ROTARY FOUNDATION
 5180 N PALM AVE SUITE 101
 FRESNO CA 93704-2230

Activity highlights

	Current period	Year-to-date
Money fund checks paid	\$.00	\$ -15,000.00
Net change from activity listed above	\$.00	\$ -15,000.00

Portfolio summary

	Current period	Year-to-date
Opening value	\$ 75,558.13	\$ 90,373.45
Net change from Activity Highlights	.00	-15,000.00
Net security earnings	47.06	229.74
Value on April 30	\$ 75,603.19	\$ 75,603.19

Earnings summary

Earnings are for the current calendar year. All prior year entries are summarized separately. This information should not be used for tax purposes. Refer to the disclosure on the back of the first page.

	Current period	Year-to-date
BS PaineWebber Money fund dividends for year(s) entries and adjustments	\$ 47.06	\$ 210.94
Net security earnings	.00	-18.80
	\$ 47.06	\$ 229.74



Bulletin Board

UBS PAINWEBBER WILL SOON HAVE A NEW BRAND NAME - UBS - AND A NEW BROKER DEALER NAME - UBS FINANCIAL SERVICES INC. RESOURCELINE 1-800-BSA-0140; ACCOUNT #: 095031093 VISIT OUR WEB SITE AT WWW.UBSPAINWEBBER.COM.

Asset summary

Refer to the disclosure on the back of the first page for information on assets excluded from this summary.

	% of portfolio	Value
Money funds/sweep options	100.00	75,603.19
Value on April 30	\$	75,603.19

Handwritten notes and calculations:
 Total 75,603.19
 47.06 + 210.94 = 257.98
 257.98 - 18.80 = 239.18
 75,558.13 + 239.18 = 75,797.31
 Total 75,603.19
 Page 1 of 2

UBS PAINWEBBER INC.
 FIG GARDEN FINANCIAL CENTER
 5200 NO. PALM, SUITE 101
 FRESNO, CA 93704-7669
 PZ1A004538-X6 - 0403 - FE - 0

Your Financial Advisor
 SAHOTA, GURKIRPAL (PAUL)
 559-226-2800/800-423-8797

**UBS PaineWebber InsightOneSM
 Business Services Account BSA[®]**

PZ1A004538-X6

Account Number: FE 31031 20

April 2003

his month at a glance

Value on March 31	\$	126,773.45
Value on April 30	\$	141,251.50
Money fund and other sweep option balance in 04/30 value	\$	26,307.64

arnings summary

arnings are for the current calendar year. All prior year entries are summarized separately. This information should not be used for tax purposes. Refer to the disclosure on the back of the first page.

	Current period	Year-to-date
S PaineWebber Money fund dividends	\$ 10.62	\$ 46.63
Interest	.00	137.26
Total current year security earnings	\$ 236.60	\$ 236.60
or year(s) entries and adjustments	\$ 247.22	\$ 420.49
Total security earnings	\$ 247.22	\$ 424.95

Asset summary

Asset summary is to the disclosure on the back of the first page for information on assets excluded from this summary.

	% of portfolio	Value
Money funds/sweep options	36.53	51,592.77
Actual funds	18.62	26,307.64
Invested assets	44.85	63,351.09
Value on April 30	100.00	\$ 141,251.50
		\$ 141,251.50

Paul Sahota
 + 247.22
 + 137.26
 = 384.48
 + 420.49
 = 804.97
 Net Page 1 of 4

FIG GARDEN ROTARY FOUNDATION
 ENDOWMENT FUND
 5180 N PALM AVE SUITE 101
 FRESNO CA 93704-2230

00000758



Bulletin Board

UBS PAINWEBBER WILL SOON HAVE A NEW BRAND NAME - UBS - AND A NEW BROKER DEALER NAME - UBS FINANCIAL SERVICES INC. RESOURCELINE 1-800-BSA-0140; ACCOUNT #: 095031031 VISIT OUR WEB SITE AT WWW.UBSPAINWEBBER.COM.

Investment objectives

The following return objective and risk profile describe overall goals for this account. For each account held, you choose one return objective and primary and, if applicable, secondary risk profile. A full description of the alternatives is included on the back of the first page. If you have questions regarding these objectives or wish to change them, please contact your Financial Advisor or Branch Manager at your branch office to update your account objectives.

Return objective: Current income & capital appreciation
Risk profile: Primary: Moderate
 Secondary: Conservative

Account Number: FE 31031 20
 Your Financial Advisor
 SAHOTA, GURKIRPAL (PAUL)
 559-226-2800/800-423-8797

**UBS PaineWebber InsightOneSM
 Business Services Account BSA[®]**

Statement Period: April 2003

PZ1A004539-X6

Activity highlights

	Current period	Year-to-date
Deposits	\$ 10,000.00	\$ 10,000.00
Program fees and related services	\$ -311.64	\$ -619.85
Change from activity listed above	\$ 9,688.36	\$ 9,380.15

Portfolio summary

	Current period	Year-to-date
Opening value	\$ 126,773.45	\$ 129,584.08
Change from Activity Highlights	\$ 9,688.36	\$ 9,380.15
Net security earnings	\$ 247.22	\$ 424.95
Change in value of investments	\$ 4,542.47	\$ 1,882.32
Value on April 30	\$ 141,251.50	\$ 141,251.50

Asset portfolio

In available, prices, income and current values may be approximate and thus gains/losses may not be accurately reflected. Refer to the disclosure on the back of the first page. \$ indicates recommendation and price target under new, * indicates recommendation and price target information temporarily suspended pending review. UBS Warburg is currently unable to display recommendation data on this company. For further information, please contact your Financial Advisor. An asterisk (*) indicates a change in the original transaction data from the prior month or the display of new data input at your branch office. Gains/losses are not calculated for zero coupon investments.

Certificates of deposit

Upon CDs

Quantity	Face value	Description	Value	Est. annual income	Trade date	Face value purchased	Purchase price	Cost basis
13,000	13,000	CD INDEPENDENT BK EAST RATE 02.00% MATURES 10/23/03 INTEREST EARNED FROM 10/23/02 1ST INTEREST PAYMENT 10/23/03	12,972.05	260	10/31/02	13,000	99,799	12,973
12,000	12,000	CD DISCOVER BANK RATE 02.50% MATURES 11/08/04 INTEREST EARNED FROM 11/08/02 1ST INTEREST PAYMENT 05/08/03	12,098.64	300	10/31/02	12,000	100,000	12,000

Fig Garden Rotary Endowment Account

Asset Allocation

US Large Co. Equity	\$ 24,388.96	17.27%
US Med/Sm Co. Equity	\$ 24,386.85	17.26%
Balanced	\$ -	%
Int'l Equity	\$ 14,575.28	10.32%
Int'l Fixed Income	\$ -	0.00%
US Fixed Income	\$ 51,592.77	36.53%
Cash / M.M	\$ 26,307.64	18.62%
	\$ 141,251.50	100.00%

Account Allocation

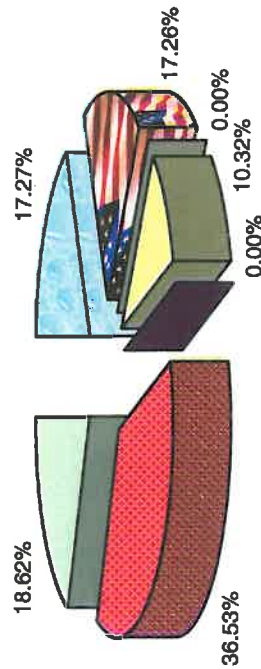

<input type="checkbox"/> US Large Co. Equity	<input checked="" type="checkbox"/> US Med/Sm Co. Equity
<input type="checkbox"/> Balanced	<input type="checkbox"/> Int'l Equity
<input type="checkbox"/> Int'l Fixed Income	<input checked="" type="checkbox"/> US Fixed Income
<input type="checkbox"/> Cash / M.M	

Investment Holdings

as of 4/30/03	Cost Basis	Value Jan 01, 2003	Value 4/30/2003	% Chg from 1/1/2003
<u>US Large Co. Equity:</u>				
Income Fund of America	\$ 11,107.99	\$ 10,417.91	\$ 11,778.48	13.06%
Pimco Value Fund	\$ 11,979.65	\$ 11,195.52	\$ 12,610.48	12.64%
<u>US Med/Sm Co. Equity:</u>				
Liberty Acorn Fund	\$ 11,094.31	\$ 10,415.86	\$ 12,117.60	16.34%
Pimco Small Cap Value	\$ 11,990.29	\$ 11,087.68	\$ 12,269.25	11.16%
<u>Balanced:</u>				
<u>Int'l Equity</u>				
Templeton Foreign	\$ 14,730.49	\$ 13,777.98	\$ 14,575.28	5.79%
<u>US & Int'l Fixed Income:</u>				
CD Independent Bank 2% due 10/23/03	\$ 12,973.87	\$ 12,916.93	\$ 12,972.05	0.43%
CD Discover Bank 2.5% due 11/08/04	\$ 12,000.00	\$ 12,043.08	\$ 12,098.64	0.46%
CD Key Bank & Trust 3.1% due 11/08/05	\$ 13,000.00	\$ 13,123.76	\$ 13,221.65	0.75%
CD Pan American Bank 3.65% due 10/30/06	\$ 12,930.84	\$ 13,185.38	\$ 13,300.43	0.87%
<u>Cash / Money Market:</u>				
Money Market	\$ 16,372.06	\$ 21,449.98	\$ 26,307.64	
TOTAL PORTFOLIO	\$ 128,179.50	\$ 129,564.08	\$ 141,251.50	9.02%
Foundation Account Value				\$ 75,603.19



Paul Sahota - Financial Advisor

FIG GARDEN ROTARY CLUB

BOARD OF DIRECTORS

Regular Meeting: 15 January 2003:

-Members Present:

*Directors:

Jamie Franklin
August Hioco
Steve Rontell
Richard Saroyan
David Stepp

*Foundation Treasurer:

Ron Fletcher

*Past President:

John T. Skewes

*Other(s) Present:

Steve Wilson, Director-
Elect

John Heberger, Past
President

*President:

Eric Fogderude

*President Elect:

Rod Coburn

*Treasurer:

Scott Bristol

*Secretary:

Doug Cords

The meeting was called to order by President Eric Fogderude at 7:04 a.m. in the new Boardroom of the newly relocated Stoughton Davidson Accountancy Corporation at 2520 West Shaw Lane, Suite 101, Fresno, California 93711.

*CONSENT ITEMS:

*Minutes Of The 18 December 2002 Regular Board Meeting		
*Attendance For Month Of December, 2002	=	73%
*Membership As Of 1 January 2003	=	104

It was MSC to approve the Consent Items as presented.

*TREASURER'S REPORT: (Scott Bristol)

Scott noted that officially posted were all current cash receipts and disbursements. Members' billings have been completed.

Full financial reports will be forthcoming at the next Board Meeting.

*SECRETARY'S REPORT:

The Secretary circulated for Board Members' review the most recent (November) District Attendance Report; Fig Garden Rotary was highlighted in the current District Newsletter for its "Holiday Gift Basket" program.

Rotary International's Semi-Annual Report And Billing was received and is in process. Secretary completes required information on members' professions and languages spoken/read, plus verifies and corrects the names and addresses as sent. This gives an opportunity to verify that all individual changes sent to Evanston have indeed been processed. Treasurer will remit to Evanston the sum of \$2,444. for our six-month billing.

The Board reviewed the Roster, a single-sheet with all contact information on members. Next month, Bill Griffith and David Bonnar, Blue Book Coordinators, will visit with the Board and at that time decisions shall be made regarding this document.

Longtime member Patty Hixson has returned from her health leave, and is welcomed back to the Club enthusiastically. She has worked diligently on projects.

Member and Board Director Wink Chase has accepted a position with his firm, Ryder Truck Rentals, in Southern California. He submitted his resignation from both the Club and the Board. In order to express the Club's sincere appreciation for his service and to facilitate his joining another Rotary Club, it was MSC to approve an "Excuse From Attendance Requirements" for Wink for the period 1 January to 30 June 2003. He will come to Friday meetings as possible. Wink will resign from the Club after he joins forces with sponsors in a Southern California Club.

Two new members were inducted into Fig Garden Rotary Club by President Eric on 10 January 2003:

*Mike Gerardi (Boy Scouts Of America)

*J. J. Roll (Kawah National Bank)

COG Co-Chair Daniel Bonyhadi was notified and is setting up a COG Social shortly for indoctrination.

Extensive discussion ensued regarding the continuing problem of current members introducing guests at Friday meetings as "prospective new members of Fig Garden Rotary," clearly against the spirit of our new member policy. Eric Fogderude, Rod Coburn and John Skewes will privately speak to those involved and a reminder shall be forthcoming from the podium at a meeting to please respect the membership proposal policy.

A thank you card from Dr. Teresa Patterson was circulated. Her resignation has been accepted and per earlier Board Action, when she wishes to return fees will be waived. She noted this will be something about which to look forward as she recovers her lost health. Board Members were encouraged to periodically call her and touch bases.

No New Member Proposals this month.

The Board charges the Secretary with tabulating and publishing in Avenues each member's Six-Month (and Year-End) attendance figures. Secretary works diligently with members who may be in trouble with the 30% attendance rule for Home Club and/or the 60% attendance rule for each six-months. In spite of these efforts, 12 members were kept in the Club with the generosity of Blood Center donations counting as make-ups. A confidential list of those names was circulated, with Directors asked to encourage those noted to get make-ups when they cannot attend our meetings.

Attendance records disclosed an exciting trend about late September - many more members than usual was delivering 100% attendance. A phone call program to encourage those who were showing 100% for the first time ensued. The result is that 55 Fig Garden Rotarians have earned 100% Attendance during the first half of President Eric's year - this is a new record for the Club, substantially surpassing our precious accomplishments. President Eric will encourage those members to repeat the performance for the final six months.

*PRESIDENT-ELECT'S REPORT: (Dr. Rod Coburn)

Plans are going well for the upcoming Auction. This week, e-mail and phone reminders have come to members from the Committee. Rod gratefully acknowledged past Auction Chairs; he shared that the amount of details that are required is amazing and he respectfully thanked his predecessors. Of particular note at this meeting for the current Auction is the work of Wes Segal for his great personal kickoff at the podium on 10 January and to Stan Skiba for his work on computer systems.

*PAST PRESIDENT'S REPORT: (John T. Skewes)

In the interest of time, John deferred his comments until a future meeting.

*PRESIDENT'S TIME: (Eric Fögderude)

It was MSC to bring onto the Board Director-Elect Matt Merzoian to fill the current vacancy for Vocational Service. David Stepp will copy a Board Booklet for Matt and he and President Eric will shortly meet to bring Matt up to speed on the position.

The President writes thank you letters to those individuals and organizations who have been a part of our Club's progress. Of late, a generous donation for Night On Fifth Avenue was received from Edmonds Jewelers.

Eric reviewed the format of the "Centennial Project" and will notice President-Elect Coburn and John Skewes of future meetings of the Area Club Presidents which calendar this agenda item.

There is a possibility that at California State University, Fresno home football games the local Rotary clubs will host a tailgate area; more discussion and information shall follow next month.

As previously noted, President Eric at year's end will recognize several members as "Most Active Rotarians," awards citing great service in the arenas of our Club's organization. He asked Board members to call with possible names and will do the same at a general Club meeting in the future.

*AVENUES OF SERVICE:

-Club Service: (August Hioco)

On February 2, Night On Fifth Avenue will take place. On February 14, the Club Meeting will be a special Valentine's Day luncheon, with spouses and others cordially invited. That evening will continue the celebration with an event at Roger Rocka's.

The month of March shall be focused entirely on the Club Auction.

Past President John Heberger gave an update on progress on the Night On Fifth Avenue event. To date, 94 persons have paid and/or sponsored participation. There is \$24,000 in merchandise available for bid. Current focus is on selling more tickets. Nancy Hinds Hospice will receive some of the proceeds.

-Community Service: (Richard Saroyan and Steve Rontell)

To date, there remain \$24,750. in uncommitted funds for Committee allocation. Eleven projects to date have been approved and/or funded.

Member Jeff Oliver brought to the Committee a request to participate in the Crime Stoppers Program, something the Club previously has supported. It was MSC to approve the sum of \$1,200. for a Gold Sponsorship. The Club is going to waive the customary plaque and tickets for two to a recognition dinner, totalling \$200. in costs to the program. That makes the entire sum of \$1,200. available for reward payments.

A letter was received from the Discovery Center requesting Club participation financially, probably in a large sum. This venue is a possible recipient of the all-area Centennial Project and thus a decision as to how/if Fig Garden Rotary Club will interact with the Discovery Center will be postponed pending decisions on the larger project. If Discovery Center is not the choice for the Centennial Project, the Club will research carefully the possibility of partnering with them.

-Vocational Service: (David Stepp)

The next venue' if the High School Scholarship Program. All schools have been contacted and initial mettings will take place in February.

-International Service: (Jamie Franklin)

Jamie reported on the follow-up of the recent Wheelchair Program. To date 95 chairs have been committed by members. An extensive discussion ensued as to how to best bill members who have not submitted checks. John Heberger will bill members.

It was MSC to release \$18,500 of Foundation Funds and authorize the International Committee to work with the Wheelchair Foundation on the country which shall receive the gifts, with further promotions to members to donate to the program.

President Eric will note from the podium the continued opportunity and shall place a notice in Avenues. When the final details of the donation are ready, a final promotion shall take place to solicit more gifts. Foundation Treasurer Ron Fletcher shall provide the check to Jamie promptly.

*OLD BUSINESS: No Old Business This Meeting.

*NEW BUSINESS:

Director Steve Rontell noted the tragic loss last week to North Fresno Rotarian Skip Carlstrom whose son was killed. Skip was a Past President of Playland/Storyland and has developed strong friendships with many Fig Garden Rotarians. In lieu of setting a Club precedent, a Board member will contribute to the memorial fund in the Club's name.

*ADJOURNMENT: The Meeting Was Adjourned at 8:24 a.m.

*NEXT MEETING: 19 February 2003.

Respectfully Submitted By Doug Cords, Ph.D., Club Secretary.

FIG GARDEN ROTARY CLUB

FOUNDATION
BOARD OF DIRECTORS

Regular Meeting: 15 January 2003:

-Members Present:

*Directors:

Jamie Franklin
August Hioco
Steve Rontell
Richard Saroyan
David Stepp

*Foundation Treasurer:

Ron Fletcher

*Past President:

John T. Skewes

*Other(s) Present:

Steve Wilson, Director-Elect

John Heberg, Past President

*President:

Eric Fogderude

*President Elect:

Rod Coburn

*Treasurer:

Scott Bristol

*Secretary:

Doug Cords

The meeting was called to concurrent order by President Eric Fogderude with the Regular Meeting of the Fig Garden Rotary Club, in the new Boardroom of the relocated Stoughton Davidson Accountancy Corporation at 2520 West Shaw Lane, Suite 101, Fresno, California 93711 at 7:04 a.m.

*TREASURER'S REPORT:

(Ron Fletcher)

Ron reviewed the current accounts, as follows:

*Unrestricted Funds:	\$105,724.00
*Permanent Funds *	129,564.00 (*Board-Designated)
*Totals:	<u>\$235,288.00</u>

All outgoing checks will be processed through the Washington Mutual accounts and receipts are being received for each expenditure. Ron reviewed the December, 2002 expenses. Encumbered, but not paid out costs are:

*Bullard Interact	*Make A Wish Foundation
*Play It Safe Foundation	*Holiday Gift Baskets

Ron reviewed the printouts of various UBS/Paine Webber accounts. He will reimburse Club Treasurer Scott Bristol for an advance on the Holiday Gift Basket account, done because of time constraints.

The Investment Committee will meet next on February 11, 2003 at 4:00 p.m.

It was MSC to approve the Treasurer's Report as presented.

-ADJOURNMENT: Concurrent With Regular Board Meeting, Adjourned At 8:24 a.m.

-NEXT MEETING: 19 February 2003.

Respectfully Submitted By Doug Cords, Ph.D., Foundation Secretary.

FIG GARDEN ROTARY FOUNDATION
STATEMENT OF REVENUE, EXPENSES AND CASH BALANCES
DECEMBER 31, 2002

	TOTAL FYE	MONTH	MONTH	MONTH	MONTH	MONTH	MONTH	MONTH	MONTH	MONTH	MONTH	MONTH	MONTH	MONTH	MONTH	MONTH	TOTAL FYE
	6/30/02	7/31/02	8/31/02	9/30/02	10/31/02	11/30/02	12/31/02	1/31/03	2/28/03	3/31/03	4/30/03	5/31/03	6/30/03	6/30/03	6/30/03	6/30/03	6/30/03
RE/ENUE:																	
AUCTION- 2003	\$0																\$0
AUCTION- 2002	67,908				472												\$472
AUCTION- 2001	4,120																0
5TH AVE FUNDRAISER	0																0
DONATIONS	12,702		400	3,800	2,125	220	345										6,890
CLEAR CHNL COM - JAZZ/COO	6,000	11,094	2,500														13,594
EARNINGS - FOUNDATION	1,810	111	98	4	4	3											319
EARNINGS - PERM. FUND	2,463	80	75	150													305
CONTRIB - FGR	18,000	0															0
CONTRIB - PERM. FUND	0	(5,433)	935	(5,430)	(2,980)	3,248	416										0
UNREAL GAIN-PERM. FUND	(24,484)																(9,244)
	88,519	5,852	4,008	(1,381)	(379)	3,472	764	0	0	0	0	0	0	0	0	0	12,336
EXPENSES:																	
ADMINISTRATIVE	16			25													\$25
AUCTION - 2003	1,000																0
AUCTION - 2002	18,669		450	317	80												847
AUCTION - 2001	2,096																0
5TH AVE FUNDRAISER	0																0
DONATIONS	7,305					250											250
AVENUES OF SERVICE:																	
COMMUNITY SERVICE	58,725		6,693	1,350	3,014												11,057
VOCATIONAL SERVICE	0																0
INTERNATIONAL SERVICE	0		560														560
VOCATIONAL SCHOLARSHIP	5,000																0
R.I. - POLIO PLUS	0																0
CONTRIB - PERM. FUND	0																0
	87,811	0	25	7,703	1,667	0	3,344	0	0	0	0	0	0	0	0	0	12,739
EXCESS OF REVENUES	708	\$5,852	\$3,983	(\$9,084)	(\$2,046)	\$3,472	(\$2,560)	\$0	\$0	\$0	\$0	\$0	\$0	\$0	\$0	\$0	(403)
OVER EXPENSES																	

BEG. CASH BALANCE	ENDING CASH BALANCE	BEG. CASH BALANCE
234,983	\$235,691	235,691
\$235,691	\$235,288	\$235,288
RESTRICTED AMOUNTS		
Paul Harris	7,945	
	\$7,945	
** REMAINING UNDESIGNATED		
COMM SER FOR 2001-02		
12/31/02	\$29,243	
EXPENDITURES ENCUMBERED	11/30/02	
Bullard Interact - 2002 Auction	\$480	
MAKE A W/IF FOUNDATION	3500	
Play it safe	4200	
HOLIDAY GIFT BASKETS	2000	
	\$10,180	
WASHINGTON MUTUAL CHECK	\$15,351	
DWR - LIQUID ASSET ACCT	90,373	
PERMANENT FUND	129,584	
	\$235,288	
DEPOSITS		
PAUL HARRIS \$345		
OTHER ENCUMBERED FUNDS		
INTERNATIONAL SERVICE		
EXCHANGE STUDENTS-\$2600		
WHEELCHAIR PROJECT-18750		
Checks written in December 2002		
2500-citizens for safer co.(10.20.life)		
514-bill roblinson-reimb.		
80-jon chessum-reimb.		
250-rotary frdnth-chexch.		
TOTAL		

Fig Garden Rotary Endowment Account

Asset Allocation

US Large Co. Equity	\$ 21,613	16.72%
US Med/Sm Co. Equity	\$ 21,454	16.59%
Balanced	\$ -	0.00%
Int'l Equity	\$ 13,778	10.66%
Int'l Fixed Income	\$ -	0.00%
US Fixed Income	\$ 51,000	39.44%
Cash/Money Market	\$ 21,450	16.59%
	\$ 129,295	100.00%

Account Allocation

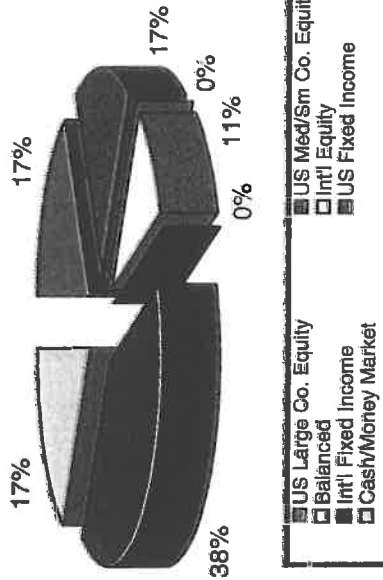

* face Value at maturity.

Investment Holdings

as of 12/31/02

Current
Values

<u>US Large Co. Equity:</u>		
Income Fund of America	\$	10,418
Pimco Value Fund	\$	11,196
<u>US Med/Sm Co. Equity:</u>		
Liberty Acorn Fund	\$	10,416
Pimco Small Cap Value	\$	11,038
<u>Balanced:</u>		
<u>Int'l Equity</u>		
Templeton Foreign	\$	13,778
<u>US & Int'l Fixed Income:</u>		
CD Independent Bank 2% due 10/23/03	\$	13,000
CD Discover Bank 2.5% due 11/08/04	\$	12,000
CD Key Bank & Trust 3.1% due 11/08/05	\$	13,000
CD Pan American Bank 3.65% due 10/30/06	\$	13,000
<u>Cash/Money Market:</u>		
Money Market	\$	21,450
TOTAL PORTFOLIO		\$ 129,295



UBS PAINWEBBER INC.
 FIG GARDEN FINANCIAL CENTER
 5200 NO. PALM, SUITE 101
 FRESNO, CA 93704-7669

Your Financial Advisor
 SAHOTA, GURKIRPAL (PAUL)
 559-226-2800/800-423-8797

**UBS PaineWebber InsightOneSM
 Business Services Account BSA[®]**

PZ1A004984-X26

Statement Period: December 2002
 Account Number: FE 31031 20

This month at a glance

Value on November 29	\$	130,841.14
Value on December 31	\$	129,564.08
Sweep balance in 12/31 value	\$	21,449.98

Earnings summary

Earnings are for the current calendar year. All prior year entries are summarized separately. This information should not be used for tax purposes. Refer to the disclosure on the back of the first page.

	Current period	Year-to-date
UBS PaineWebber Money fund dividends	\$ 19.19	\$ 105.80
Other dividends	912.92	912.92
Interest	1.69	8.36
Plus non-municipal accrued interest received	.00	.97
Less non-municipal accrued interest paid	.00	-17.06
Other	15.27	15.27
Net security earnings	\$ 949.07	\$ 1,026.26
Return of capital/principal	\$ 2.41	\$ 182.17

Investment objectives

The following return objective and risk profile describe overall goals for this account. For each account held, you choose one return objective and primary and, if applicable, secondary risk profile. A full description of the alternatives is included on the back of the first page. If you have questions regarding these objectives or wish to change them, please contact your Financial Advisor or Branch Manager at your branch office to update your account objectives.

Return objective: Current income & capital appreciation
Risk profile: Primary: Moderate Secondary: Conservative

FIG GARDEN ROTARY FOUNDATION
 ENDOWMENT FUND
 5180 N PALM AVE SUITE 101
 FRESNO CA 93704-2203

Bulletin Board

ATTENTION BOND INVESTORS: EARLY 2003 WILL SEE VERY HIGH LEVELS OF TAXABLE AND MUNICIPAL BOND REDEMPTIONS. SPEAK WITH YOUR FINANCIAL ADVISOR ABOUT YOUR HOLDINGS.

RESOURCELINE 1-800-BSA-0140: ACCOUNT #: 095031031
 VISIT OUR WEB SITE AT WWW.JBSPAINWEBBER.COM.

Asset summary

Refer to the disclosure on the back of the first page for information on assets excluded from this summary.

	% of portfolio	Value
Certificates of deposit	39.57	51,269.15
Money funds/sweep investments	16.56	21,449.98
Mutual funds	43.87	56,844.95
Net invested assets	100.00	\$ 129,564.08
Value on December 31		\$ 129,564.08

Account Number: FE 31031 20
 Your Financial Advisor
 SAHOTA,GURKIRPAL (PAUL)
 559-226-2800/800-423-8797

**UBS PaineWebber InsightOneSM
 Business Services Account BSA[®]**

PZ1A004995-X26

Statement Period: December 2002

Activity highlights

	Current period	Year-to-date
Deposits	\$.00	\$ 112,796.96
Program fees and related services	.00	-236.30
Securities transferred in (valued at time of transfer)	.00	14,474.71
Net change from activity listed above	\$.00	\$ 127,035.37

Portfolio summary

	Current period	Year-to-date
Opening value	\$ 130,841.14	\$.00
Net change from Activity Highlights	.00	127,035.37
Net security earnings	949.07	1,026.26
Change in value of investments	-2,226.13	1,502.45
Value on December 31	\$ 129,564.08	\$ 129,564.08

Asset portfolio

When available, prices, income and current values may be approximately and thus gains/losses may not be accurately reflected. Refer to the disclosure on the back of the first page. An asterisk (*) indicates a change in the original transaction data from the prior month or the display of new data input at your branch office. Gains/losses are not calculated for zero coupon investments. "Pending adjustment" or "P/A" indicates cost basis has not yet been allocated as a result of a spin-off or taxable exchange.

Certificates of deposit

Coupon CDs

Total face value at maturity	Description	Value	Est. annual income	Trade date	Face value purchased	Purchase price	Cost basis
13,000	CD INDEPENDENT BK EAST RATE 02.000% MATURES 10/23/03 INTEREST EARNED FROM 10/23/02 1ST INTEREST PAYMENT 10/23/03	12,916.93	260	10/31/02	13,000	99,799	12,973
12,000	CD DISCOVER BANK RATE 02.500% MATURES 11/08/04 INTEREST EARNED FROM 11/06/02 1ST INTEREST PAYMENT 05/08/03	12,043.08	300	10/31/02	12,000	100,000	12,000

Account Number: FE 31031 20
 Your Financial Advisor
 SAHOTA, GURKIRPAL (PAUL)
 559-226-2800/800-423-8797

**UBS PaineWebber InsightOneSM
 Business Services Account BSA[®]**

PZ1A004996-X26

Statement Period: December 2002

Coupon CDs - continued

Total face value at maturity	Description	Value	Est. annual income	Trade date	Face value purchased	Purchase price	Cost basis
13,000	CD KEY BANK AND TRUST RATE 03.100% MATURES 11/08/05	13,123.76	403	10/31/02	13,000	100,000	13,000
13,000	1ST INTEREST EARNED FROM 11/08/02						
	1ST INTEREST PAYMENT 05/08/03						
13,000	CD PAN AMERN BK FSB RATE 03.650% MATURES 10/30/06	13,185.38	475	10/31/02	13,000	99,468	12,930
	INTEREST EARNED FROM 10/30/02						
	1ST INTEREST PAYMENT 04/30/03						
51,000	Total	\$ 51,269.15	1,438				50,903

Money funds and other sweep investments

Description	Opening balance	Closing balance	Closing share price	Average yield	Dividend period	Days in period
RMA MONEY MKT. PORTFOLIO	20,498.50	21,449.98	1.00	1.06%	11/22 - 12/23	32
Total	\$ 20,498.50	\$ 21,449.98				

Mutual funds

Unrealized gain/loss indicates the cost basis versus the current value for each security lot from a tax reporting perspective and is the amount that would be realized should you sell the lot. Cost basis may need to be adjusted for return of capital payments. An "earnings" lot represents the aggregate cost basis of all dividends paid that were reinvested in the fund. If you have earnings lots, an additional calculation appears showing the overall change in value of your current position versus the money you invested in the fund. This "investment return" shows overall performance of your total investment including dividends reinvested in the fund and market appreciation or depreciation. The "investment return" figure does not include cash dividends not reinvested in the fund.

Total shares	Description	Price	Current value	Est. annual income	Trade date	Shares purchased	Purchase price	Cost basis	Unrealized Gain/loss
727	AMERICAN FUNDS INCOME FUND OF AMERICA CLASS F	14.330	10,417.91	555	10/31/02	656,000	13,910	9,124	276
1,658	FT TEMPLETON FOREIGN A	8.310	13,777.98	230	11/13/02	71,000	13,970	991	26
					10/31/02	1,537,000	8,290	12,741	31
679	LIBERTY ACORN FUND CLASS A	15.340	10,415.86		11/13/02	121,000	8,220	994	11
562	PIMCO NFJ SMALL CAP VALUE FUND CLASS A	19.640	11,037.68		10/31/02	612,000	14,890	9,112	276
					11/13/02	67,000	14,860	995	32
1,029	PIMCO PEA VALUE FUND CLASS A	10.880	11,195.52		11/04/02	510,000	19,630	10,011	5
					11/13/02	52,000	19,110	993	28
					10/31/02	936,000	10,680	9,996	187
					11/13/02	93,000	10,670	992	19
	Total	\$	56,844.95	785				55,949	891



Account Number: FE 31031 20
 Your Financial Advisor
 SAHOTA, GURKIRPAL (PAUL)
 559-226-2800/800-423-8797

**UBS PaineWebber InsightOneSM
 Business Services Account BSA[®]**

PZ1A004997-X26

Statement Period: December 2002

Monthly activity

Cash flow and security transactions

Refer to the disclosure on the back of the first page regarding the Price/Value presented for restricted securities.

Date	Activity	Description	Quantity/ Face value	Price / Value	Cash amount	Cash & Total Money fund/sweep balance
11/29		Cash, Money fund and other sweep investments balance			\$	20,498.50
12/13	ST CAP GAIN	PIMCO PEA VALUE FUND CLASS A			596.60	
12/13	DIVIDEND	SHORT TERM CAPITAL GAIN AS OF 12/12/02				
12/13	ST CAP GAIN	PIMCO NFJ SMALL CAP VALUE FUND CLASS A AS OF 12/12/02			118.64	
12/16	INTEREST	PIMCO NFJ SMALL CAP VALUE FUND CLASS A SHORT TERM CAPITAL GAIN AS OF 12/12/02			30.31	21,244.05
12/16	RETURN OF PRINCIPAL	FHLMC PL 170020 7.5000 DUE 06/01/08 FACTOR 0.019336600000 PAID ON 13000 AS OF 12/15/02			1.69	
12/17	DIVIDEND	FHLMC PL 170020 7.5000 DUE 06/01/08 FACTOR 0.019336600000 PAID ON 13000 AS OF 12/15/02			2.41	21,248.15
12/17	LT CAP GAIN	AMERICAN FUNDS INCOME FUND OF AMERICA CLASS F AS OF 12/16/02			125.92	
12/17	DIVIDEND	AMERICAN FUNDS INCOME FUND OF AMERICA CLASS F 20% RATE GAIN AS OF 12/16/02			15.27	
12/24	DIVIDEND	FT TEMPLETON FOREIGN A			41.45	21,430.79
12/31		RMA MONEY MKT. PORTFOLIO AS OF 12/23/02			19.19	21,449.98
		Closing cash, Money fund and other sweep investments balance			\$	21,449.98
		Total Money fund and other sweep investments balance			\$	21,449.98

Money funds and other sweep investments

The RMA Money Mkt. Portfolio is your primary sweep fund.

Date	Activity	Amount	Balance
11/29	Opening RMA Money Mkt. Portfolio	\$	20,498.50
12/16	BOUGHT	\$ 745.55	\$ 21,244.05
12/17	BOUGHT	4.10	21,248.15
12/18	BOUGHT	182.64	21,430.79
12/24	BOUGHT		19.19
12/31	Closing RMA Money Mkt. Portfolio	\$	\$ 21,449.98

UBS PAINWEBBER INC.
 FIG GARDEN FINANCIAL CENTER
 5200 NO. PALM, SUITE 101
 FRESNO, CA 93704-7669

Your Financial Advisor
 SAHOTA,GURKIRPAL (PAUL)
 559-226-2800/800-423-8797

**UBS PaineWebberSM
 Business Services Account BSA[®]**

PZ1A004999-X26

Statement Period: December 2002
 Account Number: FE 31093 20

This month at a glance

Value on November 29	\$	90,289.45
Value on December 31	\$	90,373.45
Sweep balance in 12/31 value	\$	90,373.45

Activity highlights

	Current period	Year-to-date
Deposits	\$.00	\$ 90,281.19
Net change from activity listed above	\$.00	\$ 90,281.19

Portfolio summary

	Current period	Year-to-date
Opening value	\$ 90,289.45	\$.00
Net change from Activity Highlights	.00	90,281.19
Net security earnings	84.00	92.26
Value on December 31	\$ 90,373.45	\$ 90,373.45

Earnings summary

Earnings are for the current calendar year. All prior year entries are summarized separately. This information should not be used for tax purposes. Refer to the disclosure on the back of the first page.

	Current period	Year-to-date
UBS PaineWebber Money fund dividends	\$ 84.00	\$ 92.26
Net security earnings	\$ 84.00	\$ 92.26

FIG GARDEN ROTARY FOUNDATION
 5190 N PALM AVE SUITE 101
 FRESNO CA 93704-2203

Bulletin Board

ATTENTION BOND INVESTORS: EARLY 2003 WILL SEE VERY HIGH LEVELS OF TAXABLE AND MUNICIPAL BOND REDEMPTIONS. SPEAK WITH YOUR FINANCIAL ADVISOR ABOUT YOUR HOLDINGS.
 RESOURCELINE 1-800-BSA-0140; ACCOUNT #: 095031093
 VISIT OUR WEB SITE AT WWW.UBSPAINWEBBER.COM.

Asset summary

Refer to the disclosure on the back of the first page for information on assets excluded from this summary.

	% of portfolio	Value
Money funds/sweep investments	100.00	90,373.45
Value on December 31	\$	90,373.45



Account Number: FE 31093 20
 Your Financial Advisor
 SAHOTA, GURKIRPAL (PAUL)
 559-226-2800/800-423-8797

**UBS PaineWebberSM
 Business Services Account BSA[®]**

Statement Period: December 2002

PZ1A006000-X26

Investment objectives

The following return objective and risk profile describe overall goals for this account. For each account held, you choose one return objective and primary and, if applicable, secondary risk profile. A full description of the alternatives is included on the back of the first page. If you have questions regarding these objectives or wish to change them, please contact your Financial Advisor or Branch Manager at your branch office to update your account objectives.

Return objective: Current income
Risk profile: Primary: Conservative Secondary: None Selected

Asset portfolio

When available, prices, income and current values may be approximately and thus gains/losses may not be accurately reflected. Refer to the disclosure on the back of the first page. An asterisk (*) indicates a change in the original transaction data from the prior month or the display of new data input at your branch office. Gains/losses are not calculated for zero coupon investments. "Pending adjustment" or "P/A" indicates cost basis has not yet been allocated as a result of a spin-off or taxable exchange.

Money funds and other sweep investments

Description	Opening balance	Closing balance	Closing share price	Average yield	Dividend period	Days in period
RMA MONEY MKT. PORTFOLIO	90,289.45	90,373.45	1.00	1.06%	11/22 - 12/23	32
Total	\$ 90,289.45	\$ 90,373.45				

Monthly activity

Cash flow and security transactions

Refer to the disclosure on the back of the first page regarding the Price/Value presented for restricted securities.

Date	Activity	Description	Quantity/ Face value	Price / Value	Cash amount	Cash & Total Money fund/sweep balance
11/29		Cash, Money fund and other sweep investments balance			\$	90,289.45
12/24	DIVIDEND	RMA MONEY MKT. PORTFOLIO AS OF 12/23/02		84.00	\$ 84.00	90,373.45
12/31		Closing cash, Money fund and other sweep investments balance			\$	90,373.45
		Total Money fund and other sweep investments balance			\$	90,373.45

Money funds and other sweep investments

The RMA Money Mkt. Portfolio is your primary sweep fund.

Date	Activity	Amount	Balance
11/29	Opening RMA Money Mkt. Portfolio	\$	90,289.45
12/24	BOUGHT AS OF 12/23/02	\$ 84.00	90,373.45
12/31	Closing RMA Money Mkt. Portfolio	\$	90,373.45

**UBS PaineWebber InsightOne™
Business Services Account BSA***

PZNL004723-716

Statement Period: October 2002

Account Number: FE 31021 20
Your Financial Advisor
SAHOTA,GURKIRPAL (PAUL)
559-225-2800/800-423-8787

Mortgage-backed securities - continued

Total original face value	Description	Price	Quantity	Est. annual income	Trade date	Price value purchased	Purchase price	Adjusted cost basis	Unrealized Gain/Loss
16,000	PRUD HOME MTG SEC P/THR SER 04-21 CL A8	100.348	1,045.82	81		16,000			
	RATE 07.800% MATURES 05/25/24								
	MAY BE CALLABLE								
	CURRENT PAR VALUE 1.042								
	Total		\$ 1,334.22	101					

Monthly activity

Cash flow and security transactions

Refer to the disclosures on the back of the first page regarding the Price/Value presented for restricted securities.

Date	Activity	Description	Quantity/ Face value	Price/ Value	Cash amount	Cash & Total Money Fund balance
09/30		Cash and total Money fund balance forward				.00
10/30	DEPOSIT	LOCAL CHECK			20,347.98	20,347.98
10/16	RECEIVE	CREDIT CASH BALANCE*		55.8		
10/16	RECEIVE	AMERICAN FUNDS INVESTMENT COMPANY OF AMERICA CL A	573.591	13,098.47	36,469.66	36,469.66
10/16	RECEIVE	PHMS 04-21 A8 07.800% DUE 06 25 24	16,000.000	1,420.68		
10/16	RECEIVE	FACTOR 0.069716310401				
10/16	RECEIVE	FHLMG PL 170020 7.5000 DUE 06/01/08	13,000.000	287.38		
10/16	RECEIVE	FACTOR 0.022810400080				
10/17	DEPOSIT	NON-LOCAL CHECK			53,659.09	59,907.68
10/21	RECEIVE	CREDIT CASH BALANCE			14.37	112,696.76
10/25	DIVIDEND	RMA MONEY MKT. PORTFOLIO AS OF 10/24/02			25.30	112,711.32
10/29	FEE BILLED	INITIAL FEE Initial Deposit \$127,620			-256.30	112,730.42
		Billing Days 09/305 Annual Fee Percentage 0.80				
10/29	RECEIVE	CREDIT CASH BALANCE			80.89	125,991.59
10/29	SOLD	AMERICAN FUNDS INVESTMENT COMPANY OF AMERICA CL A FBOLD 22870713920	-573.594	26.380	13,410.63	125,991.59
10/31		Closing cash and total Money fund balances				\$ 125,991.59
		Total Money fund balance				\$ 125,991.59

FIG GARDEN ROTARY CLUB

BOARD OF DIRECTORS

A Duly Noticed Special Meeting of the Board Of Directors Of the Fig Garden Rotary Club was held at TorNino's Restaurant at 5080 North Blackstone Avenue, Fresno, California 93710 on Friday 24 January 2003.

Members Present:

Daniel Bonyhadi
John Skewes
Ron Fletcher
Scott Bristol
Matthew Merzoian
Rod Coburn
Doug Cords
Richard Saroyan
Eric Fogderude
Jamie Franklin

Guests:

Greg Baxter, Past President
Mike Elkins

President Eric called to order the meeting at 1:41 p.m.

It was MSC to approve the Nomination of Howard Reed as new Director.

Greg Baxter, Past President, and Mike Elkins, Past Foundation Treasurer, representing Playland/Storyland, presented a financial need for insurance premium coverage. Extensive discussion regarding this premium payment, the viability of the park venues and other potential opportunities for Club participation followed.

It was MSC to approve an on-demand, no interest loan to Playland/Storyland in the amount of \$5,000. At the Club's February Board meeting, Playland/Storyland representatives shall present to the Board the financial and business plans for the coming year and possible attractions that might be the focus of Club sponsorship. Decision as to disposition of the loan agreement to be made at February meeting.

Past President Mary Lou Gunn has asked the Board to focus on specific recipients of the funds generated by her employer (Clear Channel Communications) contributions to Fig Garden Rotary, as a result of our staffing the Great Chili Cookoff and the Jazz Festival. We are asked in the future to earmark funds for specific venues and document that to Clear Channel. This item will be discussed at next month's Board meeting.

The meeting was adjourned by President Eric Fogderude at 2:06 p.m.

Respectfully Submitted By Doug Cords, Ph.D., Club Secretary.

FIG GARDEN ROTARY CLUB

BOARD OF DIRECTORS

Regular Meeting: 19 February 2003:

-Members Present:

*Directors:

Jamie Franklin
Matt Merzoian
Howard Reed
Steve Rontell
Richard Saroyan
David Stepp

*Foundation Treasurer:

Ron Fletcher

*Past-President:

John T. Skewes

*President-Elect:

Rod Coburn

*President:

Eric Fogderude

*Treasurer:

Scott Bristol

*Others Present:

Past President John Heberger
Past President Greg Baxter
Mike Elkins

The meeting was called to order by President Eric Fogderude at 7:09 a.m. in the Boardroom of the Stoughton Davidson Accountancy Corporation at 2520 West Shaw Lane, Fresno, California 93711.

*CONSENT ITEMS:

*Minutes Of The 15 January 2003 Regular Board Meeting
*Minutes Of The 24 January 2003 Special Board Meeting
*Attendance For The Month Of January, 2003 = 83%
*Membership As Of 1 February 2003 = 106

It was MSC to approve the Consent Items as presented.

*TREASURER'S REPORT:

(Scott Bristol)

Scott noted the following balances in key accounts:

*\$22,056. in checking - Cal Fed
*\$16,591. in Morgan Stanley Dean Witter
*\$29,961. in Members' Current Accounts

The Treasurer noted cash flow has increased, a result of the January Member Billing. He will work with Jon Chessum shortly to pay the Foundation Paul Harris funds from new members, plus Club match.

Expenses were incurred for President-Elect Dr. Rod Coburn's official trip to the Rotary International Convention. With regard to the 24 January Special Board Meeting, a Note Receivable (on demand) was recorded from Playland/Storyland in the amount of \$5,000. Scott has a 6-year "paper trail" on all Club income and expenditures.

It was MSC to approve the Treasurer's Report as presented.

*SECRETARY'S REPORT:

(Doug Cords)

The Board cordially welcomed new Board Members Matt Merzoian and Howard Reed, each stepping forward early to fill unexpired terms of service.

Wink Chase extends his sincere appreciation to the Board for granting an "Excuse From Attendance Requirements" during his transition to employment in Southern California.

An extensive discussion regarding the format of the "Blue Book" followed. Bill Griffith will be asked to present to the Board next month a status report, costs for Blue Book Binders and format/presentation issues as the Club transitions from its old format to the digitized arena. The Sense Of The Board is to continue with this transition and not to return to the old format.

Avenues recently published the June-December 2002 Attendance Figures, per Board requirement. The Secretary asked each Board member to identify at least one Club member at the 61-65% Attendance Level and make calls before our Friday meetings to encourage attendance and/or make-ups.

At next month's meeting, Foundation Treasurer Ron Fletcher will ask for a motion to change official signators on Club accounts.

President Eric joined the Secretary in the sad announcement of the resignations of two former Past Presidents:

- *Don Asperger
- *Robin Baldwin

Extensive discussions with each, following resignation letters, were not successful in changes of minds and each member will be missed greatly. Don asked that he be included in "hands-on" work projects and the Club Service Directors were asked to invite him. He also wishes to continue as an electronic "Avenues" recipient.

The Secretary presented Don and Robin with their official Fig Garden Rotary Club Blue Badges, as a memento of years of productive service.

New Member Proposals:

JAMES M. ROGERS -

Principal in Edmonds Jewelers
Sponsors Are John Heberger and Dave Holden
Membership Committee Has Approved Proposal
Proposed Classification: Jewelry - Retail
Proposed Mentor: Bruce Rolph

It was MSC to approve the nomination.

DENNIS ARCHER -

Century Twenty-One-Adanalian And Vasques
Sponsors Are Eric Fogderude and Jay Roll
Membership Committee Has Approved Proposal
Proposed Classification: Real Estate - Commercial Sales
Proposed Mentor: Eric Fogderude

It was MSC to approve the nomination.

*SECRETARY'S REPORT, continued:

Secretary to immediately forward candidates' files to Bob Bergin for Rotary Information invitation.

*PRESIDENT-ELECT'S REPORT: (Rod Coburn)

Rod offered personal thanks for Board members' gift items and ticket sales for the upcoming Auction, and encouraged further efforts. His goal is for 100% member participation in the event, in some fashion.

Rod will soon attend the Pre-Pets Conference and the Pets conference.

On 26 April in Porterville, a Leadership Training event will take place; further information shall follow.

Rod circulated a copy of the "Board Contact Information" for revision and corrections.

There is confusion in some official venues regarding the name and location of our Club. "Fig Garden Rotary" should be noted as a Fresno, California club. Rod will look into the situation and report on recommendations.

It was MSC to elect Mike Graves to the Board, serving a two-year term in International Service.

*PAST PRESIDENT'S REPORT: (John T. Skewes)

In the interest of time, John deferred his floor time to other matters.

*PRESIDENT'S TIME: (Eric Fogderude)

President Eric circulated a form noting the "COG Mentors," and noted that Past Presidents have/are being asked to be a Mentor.

The Centennial Project is still in its identification stages, with the focus still being on a community-wide project. Our Club may bow out if a suitable venue cannot be located soon. The Community Service Committee will present a back-up, alternative program for our Club's consideration.

District Awards' deadline is 1 April 2003. Kathy Lindstrom is the District liason and President Eric has delivered information to all concerned, with request for submissions.

Jay Roll will head up a renewed Membership Drive.

Jon Chessum and Tom Ogden are working on Polio Plus and Paul Harris fund-raising programs.

It was MSC to have no Board meeting in the month of June, 2003.

*AVENUES OF SERVICE:

-Club Service: No report this month.

-Community Service:

(Richard Saroyan and Steve Rontell)

The "Night On Fifth Avenue" generated a net amount of \$26,151. Per the commitment to Nancy Hinds Hospice, it was MSC to approve funding in the amount of \$12,500. for the Bereavement Program.

It was MSC to approve funding in the amount of \$500. for our Bullard High School Interact Club, in recognition of their volunteer efforts in the successful fund-raiser at Fresno Lincoln/Mercury/Volvo.

For Sober Graduation Night, it was MSC to approve funding in the amount of \$750. each to Bullard High School and San Joaquin Memorial High School. The Directors shall encourage daughter of member Wink Chase, Lauren, to come to the Committee with a proposal for the recently-developed student organization at Bullard which she leads, focused on drinking/drug problems.

-Vocational Service:

(Dave Stepp and Matt Merzoian)

Upcoming will be Camp Royal interviews, with Jim Gibbs heading up the program this year.

To follow will be participation in the Scholarship Programs at Bullard High School, San Joaquin Memorial High School and Fresno City College.

-International Service:

(Jamie Franklin and Howard Reed)

Chris Lewis from the Wheelchair Foundation is being contacted to set up possible member participation in the actual delivery of the wheelchairs. The Directors requested the previously-approved check for \$18,500.

Howard attended a meeting on 1 February for the Outbound Exchange Program. Our student wishes to raise funds for expenses. Howard will ask Avenues to publish a notice of her availability for work and will also contact Bill Griffith to offer her services for data input on the Blue Book Project.

*OLD BUSINESS:

Past President Greg Baxter and Mike Elkins presented an update to the Board budgets and projections for Playland/Storyland, per the January Special Board Meeting. There have literally been three years of "downtime" at Playland, due to rides being condemned for new safety regulations. The Park remained partly open due to contributions and a State grant. The 2003 projections show the bank line of credit being paid off by year's end. Blair Looney of Charles Looney Advertising will donate advertising consultancy this year. Extensive discussion followed regarding the cost and income projections and the future of Playland and Storyland. Our Club is blessed with several members actively volunteering on the parks' Board Of Directors.

The loan matter is referred to the Community Service Avenue for recommendations on disposition of the \$5,000 on-demand loan and possible projects.

Sincere thanks were offered to the Board by Greg and Mike for coming to the aid of the park in a financial crunch time.

-NEW BUSINESS:

There was no New Business presented at this meeting.

*ADJOURNMENT: President Eric Adjourned The Meeting At 9:09 a.m.

*NEXT MEETING:: 19 March 2003

Respectfully Submitted By Doug Cords, Ph.D., Club Secretary.

Rotary Club of Fig Garden

Club Accounts

Balance sheet for period ending 31 January 03

Printed 2/15/03

ACCUMULATED FUNDS

Club Funds

Balance at beginning of year	\$56,352.89
Excess (Deficit) for period	\$15,097.85
Balance to Date	\$71,450.74

TOTAL FUNDS	\$71,450.74
--------------------	--------------------

Represented by:

ASSETS

Checking Account-Cal Fed	\$22,056.13
Morgan Stanley Dean Witter	\$16,591.61
Member's Current Accounts	\$29,961.00
Note Rec - Playland	\$5,000.00
Total Assets	\$73,608.74

LIABILITIES

PHF Clearing	\$325.00
Woodward Park Bench Project	\$1,500.00
Suspense	\$333.00
Total Liabilities	\$2,158.00

NET ASSETS	\$71,450.74
-------------------	--------------------

Rotary Club of Fig Garden

Club Accounts

Income & Expenditure: Current Month & Year to Date to January 03

Printed 2/15/03

	Current Month	Year to Date
INCOME		
Member Dues	\$0.00	\$26,875.00
Terminated Members	(\$125.00)	(\$125.00)
Admin Charge-New Members	\$160.00	\$320.00
Fines	(\$50.00)	\$11,462.50
Raffle	\$105.00	\$730.00
Interest	\$0.00	\$100.80
Roger Rockas	\$0.00	\$76.00
Retreat	\$0.00	\$3,901.00
Races	\$0.00	\$1,957.00
Tailgate	\$0.00	\$520.00
Offsite Lunches	\$0.00	\$732.00
Christmas Party	\$455.00	\$2,525.00
Gift Exchange/Toys for Tots	\$99.00	\$121.00
Auction	\$0.00	\$100.00
Miscellaneous Income	\$0.00	\$979.04
Total Income	\$644.00	\$50,274.34
EXPENDITURE		
R.I. Dues	\$2,483.00	\$5,616.75
District Dues	\$2,535.52	\$5,242.94
Supplies and Postage	\$298.75	\$1,594.70
Computer Expenses and Web Site	\$0.00	\$522.00
Officer Expense	\$515.00	\$3,997.01
Terminated Members	\$0.00	\$250.00
Miscellaneous Expense	\$0.00	\$1,572.00
Bank Charges	\$0.00	\$7.72
Lunch-Tornino's	\$352.00	\$830.50
Demotion Party	\$0.00	\$512.52
Banners, Badges, Pins	\$179.39	\$563.82
Hospitality and Fellowship	\$100.65	\$1,915.74
Rotary Information	\$62.47	\$62.47
Retreat	\$0.00	\$4,504.78
The Races	\$0.00	\$1,934.34
Mystery Dinner	\$0.00	\$34.62
Tailgate	\$82.11	\$82.11
Offsite Lunches	\$0.00	\$748.04
Christmas Party	\$0.00	\$3,242.81
Camp Royal	\$0.00	(\$58.38)
Christmas Food Basket	\$0.00	\$2,000.00
Total Expenditure	\$6,608.89	\$35,176.49
Excess (Deficit)	(\$5,964.89)	\$15,097.85

Rotary Club of Fig Garden

Club Accounts

Income & Expenditure: Comparison to Budget to January 03

Printed 2/15/03

	Current Month	Year to Date	Budget to Date	Variance
INCOME				
Member Dues	\$0.00	\$26,875.00	\$28,000.00	(\$1,125.00)
Terminated Members	(\$125.00)	(\$125.00)	\$0.00	(\$125.00)
Admin Charge-New Members	\$160.00	\$320.00	\$700.00	(\$380.00)
Fines	(\$50.00)	\$11,462.50	\$10,000.00	\$1,462.50
Raffle	\$105.00	\$730.00	\$700.00	\$30.00
Interest	\$0.00	\$100.80	\$350.00	(\$249.20)
Roger Rockas	\$0.00	\$76.00	\$0.00	\$76.00
Retreat	\$0.00	\$3,901.00	\$3,800.00	\$101.00
Races	\$0.00	\$1,957.00	\$0.00	\$1,957.00
Tailgate	\$0.00	\$520.00	\$720.00	(\$200.00)
Offsite Lunches	\$0.00	\$732.00	\$1,050.00	(\$318.00)
Christmas Party	\$455.00	\$2,525.00	\$3,000.00	(\$475.00)
Gift Exchange/Toys for Tots	\$99.00	\$121.00	\$0.00	\$121.00
Auction	\$0.00	\$100.00	\$0.00	\$100.00
Miscellaneous Income	\$0.00	\$979.04	\$350.00	\$629.04
Total Income	\$644.00	\$50,274.34	\$48,670.00	\$1,604.34
EXPENDITURE				
R.I. Dues	\$2,483.00	\$5,616.75	\$5,800.00	\$183.25
District Dues	\$2,535.52	\$5,242.94	\$5,800.00	\$557.06
Supplies and Postage	\$298.75	\$1,594.70	\$1,050.00	(\$544.70)
Computer Expenses and Web Site	\$0.00	\$522.00	\$210.00	(\$312.00)
Officer Expense	\$515.00	\$3,997.01	\$100.00	(\$3,897.01)
Terminated Members	\$0.00	\$250.00	\$1,200.00	\$950.00
Miscellaneous Expense	\$0.00	\$1,572.00	\$700.00	(\$872.00)
Bank Charges	\$0.00	\$7.72	\$0.00	(\$7.72)
Dist Conf and Assembly	\$0.00	\$0.00	\$250.00	\$250.00
Lunch-Tornino's	\$352.00	\$830.50	\$1,225.00	\$394.50
Programs	\$0.00	\$0.00	\$350.00	\$350.00
Speakers	\$0.00	\$0.00	\$1,050.00	\$1,050.00
Demotion Party	\$0.00	\$512.52	\$0.00	(\$512.52)
Bulletin	\$0.00	\$0.00	\$700.00	\$700.00
Banners, Badges, Pins	\$179.39	\$563.82	\$525.00	(\$38.82)
Hospitality and Fellowship	\$100.65	\$1,915.74	\$2,625.00	\$709.26
Blue Book	\$0.00	\$0.00	\$525.00	\$525.00
Rotary Information	\$62.47	\$62.47	\$175.00	\$112.53
Membership	\$0.00	\$0.00	\$350.00	\$350.00
Retreat	\$0.00	\$4,504.78	\$5,300.00	\$795.22
The Races	\$0.00	\$1,934.34	\$0.00	(\$1,934.34)
Mystery Dinner	\$0.00	\$34.62	\$0.00	(\$34.62)
Tailgate	\$82.11	\$82.11	\$860.00	\$777.89
Offsite Lunches	\$0.00	\$748.04	\$1,200.00	\$451.96
Christmas Party	\$0.00	\$3,242.81	\$4,000.00	\$757.19
Camp Royal	\$0.00	(\$58.38)	\$0.00	\$58.38
Christmas Food Basket	\$0.00	\$2,000.00	\$0.00	(\$2,000.00)
Community Projects	\$0.00	\$0.00	\$875.00	\$875.00
Bullard Interact	\$0.00	\$0.00	\$175.00	\$175.00
SJM Interact	\$0.00	\$0.00	\$175.00	\$175.00
Youth Exchange	\$0.00	\$0.00	\$175.00	\$175.00
Paul Harris	\$0.00	\$0.00	\$350.00	\$350.00
Total Expenditure	\$6,608.89	\$35,176.49	\$35,745.00	\$568.51
Excess (Deficit)	(\$5,964.89)	\$15,097.85	\$12,925.00	\$1,035.83

Rotary Club of Fig Garden

Club Accounts

Income & Expenditure: Current Year vs Previous Year to January 03

Printed 2/15/03

	Month		Year to Date	
	Current Year	Previous Year	Current Year	Previous Year
INCOME				
Member Dues	\$0.00	\$13,750.00	\$26,875.00	\$27,557.50
Terminated Members	(\$125.00)	\$0.00	(\$125.00)	\$0.00
Admin Charge-New Members	\$160.00	\$0.00	\$320.00	\$720.00
Fines	(\$50.00)	\$0.00	\$11,462.50	\$10,487.50
Raffle	\$105.00	\$60.00	\$730.00	\$906.00
Interest	\$0.00	\$0.00	\$100.80	\$236.34
Demotion Party	\$0.00	\$0.00	\$0.00	\$60.00
Roger Rockas	\$0.00	\$0.00	\$76.00	\$0.00
Retreat	\$0.00	\$0.00	\$3,901.00	\$3,575.00
Races	\$0.00	\$0.00	\$1,957.00	\$2,188.00
Tailgate	\$0.00	\$0.00	\$520.00	\$700.00
Offsite Lunches	\$0.00	\$0.00	\$732.00	\$801.00
Christmas Party	\$455.00	\$0.00	\$2,525.00	\$3,600.00
Gift Exchange/Toys for Tots	\$99.00	\$0.00	\$121.00	\$0.00
Auction	\$0.00	\$0.00	\$100.00	\$65.00
Miscellaneous Income	\$0.00	\$175.00	\$979.04	\$1,679.96
Community Projects	\$0.00	\$0.00	\$0.00	\$2,500.00
Wheelchair Project	\$0.00	\$140.00	\$0.00	\$140.00
Paul Harris	\$0.00	\$0.00	\$0.00	\$315.00
Total Income	\$644.00	\$14,125.00	\$50,274.34	\$55,531.30
EXPENDITURE				
R.I. Dues	\$2,483.00	\$0.00	\$5,616.75	\$2,694.04
District Dues	\$2,535.52	\$2,706.18	\$5,242.94	\$5,647.68
Supplies and Postage	\$298.75	\$109.93	\$1,594.70	\$839.12
Computer Expenses and Web Site	\$0.00	\$0.00	\$522.00	\$0.00
Officer Expense	\$515.00	\$0.00	\$3,997.01	\$38.21
Terminated Members	\$0.00	\$0.00	\$250.00	\$2,530.00
Miscellaneous Expense	\$0.00	\$0.00	\$1,572.00	\$303.00
Bank Charges	\$0.00	\$0.00	\$7.72	\$7.48
Lunch-Tornino's	\$352.00	\$0.00	\$830.50	\$1,054.50
FGR Foundation	\$0.00	(\$1,500.00)	\$0.00	\$5,000.00
Demotion Party	\$0.00	\$0.00	\$512.52	\$329.41
Bulletin	\$0.00	\$359.85	\$0.00	\$359.85
Banners, Badges, Pins	\$179.39	\$0.00	\$563.82	\$651.58
Hospitality and Fellowship	\$100.65	\$70.15	\$1,915.74	\$1,832.66
Blue Book	\$0.00	\$463.86	\$0.00	\$953.07
Rotary Information	\$62.47	\$0.00	\$62.47	\$182.25
Retreat	\$0.00	\$0.00	\$4,504.78	\$4,360.47
The Races	\$0.00	\$0.00	\$1,934.34	\$2,080.22
Mystery Dinner	\$0.00	\$0.00	\$34.62	\$0.00
Tailgate	\$82.11	\$0.00	\$82.11	\$823.76
Offsite Lunches	\$0.00	\$0.00	\$748.04	\$839.87
Christmas Party	\$0.00	\$264.31	\$3,242.81	\$4,981.19
Auction	\$0.00	\$218.26	\$0.00	\$218.26
Camp Royal	\$0.00	\$0.00	(\$58.38)	(\$66.83)
Christmas Food Basket	\$0.00	\$0.00	\$2,000.00	\$0.00
Community Projects	\$0.00	\$0.00	\$0.00	\$5,175.00
Youth Exchange	\$0.00	\$0.00	\$0.00	\$53.76
Paul Harris	\$0.00	\$1,500.00	\$0.00	\$1,500.00
Total Expenditure	\$6,608.89	\$4,192.54	\$35,176.49	\$42,388.55

Rotary Club of Fig Garden

Club Accounts

Income & Expenditure: CurrentYear vs Previous Year to January 03

Printed 2/15/03

	Month		Year to Date	
	Current Year	Previous Year	Current Year	Previous Year
Excess (Deficit)	(\$5,964.89)	\$9,932.46	\$15,097.85	\$13,142.75

FIG GARDEN ROTARY CLUB

FOUNDATION

BOARD OF DIRECTORS

Regular Meeting: 19 February 2003:

-Members Present:

*Directors:

Jamie Franklin
Matt Merzoian
Howard Reed
Steve Rontell
Richard Saroyan
David Stepp

*President:

Eric Fogderude

*Treasurer:

Scott Bristol

*Foundation Treasurer:

Ron Fletcher

*Past-President:

John T. Skewes

*President-Elect:

Rod Coburn

*Secretary:

Doug Cords

*Others Present:

Past President John Heberger
Past President Greg Baxter
Mike Elkins

The meeting was called to concurrent order by President Eric Fogderude with the Regular Board Meeting of the Fig Garden Rotary Club, in the Boardroom of the Stoughton Davidson Accountancy Corporation at 2520 West Shaw Lane, Suite 101, Fresno, California 93711 at 7:08 a.m.

*TREASURER'S REPORT:

(Ron Fletcher)

Due to family health issues, the Treasurer's Report is deferred and will be given next month.

*ADJOURNMENT: Concurrent With Regular Meeting, Adjourned At 9:09 a.m.

*NEXT MEETING: 19 March 2003

Respectfully Submitted By Doug Cords, Ph.D., Foundation Secretary.

FIG GARDEN ROTARY CLUB

BOARD OF DIRECTORS

-Regular Meeting: 19 March 2003:

-Members Present:

*Directors:

August Hioco
Matt Merzoian
Howard Reed
Steve Rontell
David Stepp

*Club Treasurer:

Scott Bristol

*President-Elect:

Rod Coburn

*Others Present:

Past President John Heberger
Debra Coe

*President:

Eric Fogderude

*Secretary:

Doug Cords

The meeting was called to order by President Eric Fogderude at 7:07 a.m. in the Boardroom of the Stoughton Davidson Accountancy Corporation at 2530 West Shaw Lane, Suite 101, Fresno, California 93711.

*CONSENT ITEMS:

*Minutes Of The 19 February 2003 Regular Board Meeting
*Attendance For The Month Of February, 2003 = 84%
*Membership As Of 1 March 2002 = 104,

It was MSC to approve the Consent Items as presented.

*TREASURER'S REPORT:

(Scott Bristol)

Scott noted the following balances, in key accounts:

Checking:	\$35,261.
Morgan Stanley Dean Witter	16,591.
Members' Accounts Receivable:	16,171.
Note Receivable/Playland:	5,000.

The Woodward Park Bench project has a liability of \$1,500.

Accounts are either on budget or ahead of budget for the fiscal year.

Scott reviewed the status of the Monthly Aged Trial President, a copy of which is given to the President. Some members have large Accounts Payable Balances - eight between \$600. and \$1,442. The President will contact each, with the goal of generating a monthly workout payment schedule.

It was MSC to approve the Treasurer's Report as presented.

*SECRETARY'S REPORT:

(Doug Cords)

A report was given of the COG Members who must attend a Board Meeting as part of the requirements of the Club:

- *Tony Carr
- *Fernando Morales
- *Joetta Winter
- *Doug Brinkley
- *Jim Rodgers
- *Dennis Archer

The "Clovis Unified School District Today" newspaper was circulated for review, as it carried a piece about Fig Garden Rotary Club's Program at Nelson School, spearheaded by Bill Robinson. The school shall greet a new Principal next year, Rich Smith, presently Principal at Dry Creek School. He is a dynamic, acclaimed leader who can be a key player in our relationship with the school.

The latest District Attendance Figures were circulated, from January; our Club leads the local clubs in average monthly attendance, a regular and strong pattern.

It was MSC to approve April 18, 2003, as a "Dark Day" to observe Good Friday. Secretary to notify Avenues Editor and TorNino's.

COG Member, per Daniel Bonyhadi, has completed all the requirements and his Blue Badge is ready for presentation at a Friday meeting, by President Eric Fogderude. Bob Whalen shall receive his Blue Badge on 28 March 2003.

Member Rob Morello has changed jobs and unfortunately displays severe attendance issues. Director Bonyhadi and the Secretary have worked with him to try to resolve, but travel precludes regular attendance. He has notified the President of his intention to resign. It is the will of the Board that this letter to be written be appropriately dated to reflect his last attendance in January. Secretary to so inform Rob.

The New Member Pipeline has no new candidates this month.

Dennis Archer and Jim Rodgers were inducted as new members on Friday, 14 March 2003.

The Board held an extensive discussion regarding the RI-chartered "E-Club" format and its potential for abuse in terms of make-ups. President-Elect Rod Coburn and the Secretary will bring to the Board a draft of a revised Attendance Credit policy, to include this E-Club scenario and others, in the near future.

*PRESIDENT ELECT'S REPORT:

No report this month.

*PRESIDENT-ELECT'S REPORT:

(Rod Coburn)

The Golf Team is assembled and ready for its annual participation in the Selma Rotary Club's Tournament.

*PRESIDENT-ELECT, Continued:

In his role as Auction Chair, Rod reported on Preliminary Numbers from the annual fund-raiser from 15 March, as follows:

\$55,585. in merchandise income
3,010. in income from raffle
\$58,595. deposited in bank .

This is non-inclusive of ticket sales. The "Ballpark Return" is in the neighborhood of \$50,000. Several hardware/equipment purchases were made this year, which shall be utilized in future fund-raising events.

The PETS Conference was productive and informative.

Member Tom Ogden will take over as "Senior Co-Chair" For the Foundation.

Rod is looking ahead to schedule next year's Auction, around possible local venue scheduling conflicts which might detract from our efforts.

On April 26th, returning Board Members are encouraged to attend a Training Meeting, held at Porterville College.

On April 22-25, 2004, the District Conference shall be held at Tenaya Lodge.

Rod delivered to Avenues Editor an updated Area Club Calendar of meetings, times and places, for our members' make-ups.

*PRESIDENT'S TIME: (Eric Fogderude)

On May 16-18, the next District Conference will be held. Applications are available from Eric, and participation is stressed and important.

The District's Newsletter was circulated for members' reading.

A new edition of the "Club Roster" has been published and will be available shortly. The goal is to revise and publish each six months.

There will be forthcoming a Membership Drive.

A block of tickets for "Wrinkles" has been set aside for members' purchases.

The "Centennial Project" proposal for an Educational Center at Scout Island was discussed. A Blue Ribbon Committee shall be formed immediately to recommend to the Board options and strategy for analyzing the possibility of our participation in this long-term (at least 2 years) project. President-Elect Rod Coburn will spearhead the group.

Matching funds are still available, per prior Board Action, for members to utilize in making Paul Harris Contributions. It was MSC to extend the deadline to April 15, 2003. Past President Heberger noted, with Board support, that the members of the Foundation Leadership propose a "matching funds" arena, which might be different from that which the Board approved.

*AVENUES OF SERVICE:

-Club Service: (August Hioco)

April 25: Golf Tournament and COG Social - the Club's meeting this Friday
(Secretary to notify TorNino's and Avenues)

May 24: Mystery Dinner

June 6: Wrinkles (tentative)

Late June: Demotion Party

Some members have requested earlier notification of Club activities, so scheduling can be effected. The Chairs will happily get out notices as soon as possible, continuing their strong efforts to support members.

It was suggested that the Club might utilize the Rotary Amphitheater for a future event.

-Community Service: (Steve Rontell)

It was MSC to allocate the sum of \$2500. to Break The Barriers for purchase of tumbling/landing mats, hopefully with the FGR logo affixed.

It was MSC to approve the sum of \$500. for the Bullard Talent School, to help fund travel to New York for the "Festival Of Gold" Music Competition.

Debra Coe and John Heberger gave a superb presentation about the "Spirit Of Woman Of California, Incorporated." It was MSC to allocate the sum of \$7,450. for purchase of equipment and supplies for apartment refurnishings to support this program.

-Vocational Service: (Dave Stepp)

On May 4, the high school students and their counselors will join the Club's meeting to receive scholarships and recognition.

Camp Royal interview dates will be set soon.

-International Service: (Howard Reed)

On 24 March, Rotary Club Of Fresno will have a "wheelchair project" program. Jamie Franklin will visit the Club, to learn and be therefore well versed in the "ins and outs" of the program. The guest speaker is from Costa Rica, where a previous donation was made.

*OLD BUSINESS:

The "Centennial Project" was previously covered under "President's Time."

*NEW BUSINESS:

There was no New Business this meeting.

*ADJOURNMENT: President Eric adjourned the meeting at 8:56 a.m.

*NEXT MEETING: 16 April 2003.

Respectfully Submitted By Doug Cords, Ph.D., Club Secretary.

Rotary Club of Fig Garden

Club Accounts

Balance sheet for period ending 28 February 03

Printed 3/17/03

ACCUMULATED FUNDS

Club Funds

Balance at beginning of year	\$56,352.89
Excess (Deficit) for period	\$14,846.57
Balance to Date	\$71,199.46

TOTAL FUNDS	<u>\$71,199.46</u>
--------------------	--------------------

Represented by:

ASSETS

Checking Account-Cal Fed	\$35,261.85
Morgan Stanley Dean Witter	\$16,591.61
Member's Current Accounts	\$16,171.00
Note Rec - Playland	\$5,000.00
Total Assets	<u>\$73,024.46</u>

LIABILITIES

PHF Clearing	\$325.00
Woodward Park Bench Project	\$1,500.00
Total Liabilities	<u>\$1,825.00</u>

NET ASSETS	<u>\$71,199.46</u>
-------------------	--------------------

Rotary Club of Fig Garden

Club Accounts

Income & Expenditure: Current Month & Year to Date to February 03

Printed 3/ 8/03

	Current Month	Year to Date
INCOME		
Member Dues	\$0.00	\$26,875.00
Terminated Members	\$0.00	(\$125.00)
Admin Charge-New Members	\$0.00	\$320.00
Fines	\$0.00	\$11,462.50
Raffle	\$68.00	\$798.00
Interest	\$0.00	\$100.80
Roger Rockas	\$2,587.50	\$2,663.50
Retreat	\$0.00	\$3,901.00
Races	\$0.00	\$1,957.00
Tailgate	\$0.00	\$520.00
Offsite Lunches	\$0.00	\$732.00
Christmas Party	\$0.00	\$2,525.00
Gift Exchange/Toys for Tots	\$0.00	\$121.00
Auction	\$0.00	\$100.00
Miscellaneous Income	\$0.00	\$979.04
Total Income	\$2,655.50	\$52,929.84
EXPENDITURE		
R.I. Dues	\$0.00	\$5,616.75
District Dues	\$0.00	\$5,242.94
Supplies and Postage	\$0.00	\$1,594.70
Computer Expenses and Web Site	\$0.00	\$522.00
Officer Expense	\$0.00	\$3,997.01
Terminated Members	\$0.00	\$250.00
Miscellaneous Expense	\$56.78	\$1,628.78
Bank Charges	\$0.00	\$7.72
Lunch-Tornino's	\$0.00	\$830.50
Programs	\$200.00	\$200.00
Demotion Party	\$0.00	\$512.52
Banners, Badges, Pins	\$0.00	\$563.82
Hospitality and Fellowship	\$0.00	\$1,915.74
Rotary Information	\$0.00	\$62.47
Roger Rockas	\$2,550.00	\$2,550.00
Retreat	\$0.00	\$4,504.78
The Races	\$0.00	\$1,934.34
Mystery Dinner	\$0.00	\$34.62
Tailgate	\$0.00	\$82.11
Offsite Lunches	\$0.00	\$748.04
Christmas Party	\$0.00	\$3,242.81
Camp Royal	\$0.00	(\$58.38)
Christmas Food Basket	\$0.00	\$2,000.00
Total Expenditure	\$2,806.78	\$37,983.27
Excess (Deficit)	(\$151.28)	\$14,946.57

Rotary Club of Fig Garden

Club Accounts

Income & Expenditure: Current Year vs Previous Year to February 03

Printed 3/ 8/03

	Month		Year to Date	
	Current Year	Previous Year	Current Year	Previous Year
INCOME				
Member Dues	\$0.00	\$0.00	\$26,875.00	\$27,557.50
Terminated Members	\$0.00	\$0.00	(\$125.00)	\$0.00
Admin Charge-New Members	\$0.00	\$0.00	\$320.00	\$720.00
Fines	\$0.00	\$0.00	\$11,462.50	\$10,487.50
Raffle	\$68.00	\$242.00	\$798.00	\$1,148.00
Interest	\$0.00	\$0.00	\$100.80	\$236.34
Demotion Party	\$0.00	\$0.00	\$0.00	\$60.00
Roger Rockas	\$2,587.50	\$0.00	\$2,663.50	\$0.00
Retreat	\$0.00	\$0.00	\$3,901.00	\$3,575.00
Races	\$0.00	\$0.00	\$1,957.00	\$2,188.00
Tailgate	\$0.00	\$0.00	\$520.00	\$700.00
Offsite Lunches	\$0.00	\$0.00	\$732.00	\$801.00
Christmas Party	\$0.00	\$0.00	\$2,525.00	\$3,600.00
Gift Exchange/Toys for Tots	\$0.00	\$0.00	\$121.00	\$0.00
Auction	\$0.00	\$450.00	\$100.00	\$515.00
Miscellaneous Income	\$0.00	\$0.00	\$979.04	\$1,679.96
Community Projects	\$0.00	\$0.00	\$0.00	\$2,500.00
Wheelchair Project	\$0.00	\$0.00	\$0.00	\$140.00
Paul Harris	\$0.00	\$0.00	\$0.00	\$315.00
Total Income	\$2,655.50	\$692.00	\$52,929.84	\$56,223.30
EXPENDITURE				
R.I. Dues	\$0.00	\$2,661.00	\$5,616.75	\$5,355.04
District Dues	\$0.00	\$0.00	\$5,242.94	\$5,647.68
Supplies and Postage	\$0.00	\$35.66	\$1,594.70	\$874.78
Computer Expenses and Web Site	\$0.00	\$0.00	\$522.00	\$0.00
Officer Expense	\$0.00	\$240.75	\$3,997.01	\$278.96
Terminated Members	\$0.00	\$0.00	\$250.00	\$2,530.00
Miscellaneous Expense	\$56.78	\$586.00	\$1,628.78	\$889.00
Bank Charges	\$0.00	\$0.00	\$7.72	\$7.48
Lunch-Tornino's	\$0.00	\$0.00	\$830.50	\$1,054.50
FGR Foundation	\$0.00	\$0.00	\$0.00	\$5,000.00
Programs	\$200.00	\$0.00	\$200.00	\$0.00
Demotion Party	\$0.00	\$0.00	\$512.52	\$329.41
Bulletin	\$0.00	\$0.00	\$0.00	\$359.85
Banners, Badges, Pins	\$0.00	\$127.44	\$563.82	\$779.02
Hospitality and Fellowship	\$0.00	\$0.00	\$1,915.74	\$1,832.66
Blue Book	\$0.00	\$0.00	\$0.00	\$953.07
Rotary Information	\$0.00	\$0.00	\$62.47	\$182.25
Roger Rockas	\$2,550.00	\$0.00	\$2,550.00	\$0.00
Retreat	\$0.00	\$0.00	\$4,504.78	\$4,360.47
The Races	\$0.00	\$0.00	\$1,934.34	\$2,080.22
Mystery Dinner	\$0.00	\$0.00	\$34.62	\$0.00
Tailgate	\$0.00	\$0.00	\$82.11	\$823.76
Offsite Lunches	\$0.00	\$0.00	\$748.04	\$839.87
Christmas Party	\$0.00	\$0.00	\$3,242.81	\$4,981.19
Valentines Day	\$0.00	\$151.45	\$0.00	\$151.45
Auction	\$0.00	\$500.00	\$0.00	\$718.26
Camp Royal	\$0.00	\$0.00	(\$58.38)	(\$66.83)
Christmas Food Basket	\$0.00	\$0.00	\$2,000.00	\$0.00
Community Projects	\$0.00	\$0.00	\$0.00	\$5,175.00
Youth Exchange	\$0.00	\$0.00	\$0.00	\$53.76

Rotary Club of Fig Garden

Club Accounts

Income & Expenditure: CurrentYear vs Previous Year to February 03

Printed 3/ 8/03

	Month		Year to Date	
	Current Year	Previous Year	Current Year	Previous Year
Paul Harris	\$0.00	\$0.00	\$0.00	\$1,500.00
Total Expenditure	\$2,806.78	\$4,302.30	\$37,983.27	\$46,690.85
Excess (Deficit)	(\$151.28)	(\$3,610.30)	\$14,946.57	\$9,532.45

Rotary Club of Fig Garden

Club Accounts

Income & Expenditure: Comparison to Budget to February 03

Printed 3/ 8/03

	Current Month	Year to Date	Budget to Date	Variance
INCOME				
Member Dues	\$0.00	\$26,875.00	\$28,000.00	(\$1,125.00)
Terminated Members	\$0.00	(\$125.00)	\$0.00	(\$125.00)
Admin Charge-New Members	\$0.00	\$320.00	\$800.00	(\$480.00)
Fines	\$0.00	\$11,462.50	\$10,000.00	\$1,462.50
Raffle	\$68.00	\$798.00	\$800.00	(\$2.00)
Interest	\$0.00	\$100.80	\$400.00	(\$299.20)
Roger Rockas	\$2,587.50	\$2,663.50	\$0.00	\$2,663.50
Retreat	\$0.00	\$3,901.00	\$3,800.00	\$101.00
Races	\$0.00	\$1,957.00	\$0.00	\$1,957.00
Tailgate	\$0.00	\$520.00	\$720.00	(\$200.00)
Offsite Lunches	\$0.00	\$732.00	\$1,200.00	(\$468.00)
Christmas Party	\$0.00	\$2,525.00	\$3,000.00	(\$475.00)
Gift Exchange/Toys for Tots	\$0.00	\$121.00	\$0.00	\$121.00
Auction	\$0.00	\$100.00	\$0.00	\$100.00
Miscellaneous Income	\$0.00	\$979.04	\$400.00	\$579.04
Total Income	\$2,655.50	\$52,929.84	\$49,120.00	\$3,809.84
EXPENDITURE				
R.I. Dues	\$0.00	\$5,616.75	\$5,800.00	\$183.25
District Dues	\$0.00	\$5,242.94	\$5,800.00	\$557.06
Supplies and Postage	\$0.00	\$1,594.70	\$1,200.00	(\$394.70)
Computer Expenses and Web Site	\$0.00	\$522.00	\$240.00	(\$282.00)
Officer Expense	\$0.00	\$3,997.01	\$450.00	(\$3,547.01)
Terminated Members	\$0.00	\$250.00	\$1,200.00	\$950.00
Miscellaneous Expense	\$56.78	\$1,628.78	\$800.00	(\$828.78)
Bank Charges	\$0.00	\$7.72	\$0.00	(\$7.72)
Dist Conf and Assembly	\$0.00	\$0.00	\$250.00	\$250.00
Lunch-Tornino's	\$0.00	\$830.50	\$1,400.00	\$569.50
Programs	\$200.00	\$200.00	\$400.00	\$200.00
Speakers	\$0.00	\$0.00	\$1,200.00	\$1,200.00
Demotion Party	\$0.00	\$512.52	\$0.00	(\$512.52)
Bulletin	\$0.00	\$0.00	\$800.00	\$800.00
Banners, Badges, Pins	\$0.00	\$563.82	\$600.00	\$36.18
Hospitality and Fellowship	\$0.00	\$1,915.74	\$3,000.00	\$1,084.26
Blue Book	\$0.00	\$0.00	\$600.00	\$600.00
Rotary Information	\$0.00	\$62.47	\$200.00	\$137.53
Membership	\$0.00	\$0.00	\$400.00	\$400.00
Roger Rockas	\$2,550.00	\$2,550.00	\$0.00	(\$2,550.00)
Retreat	\$0.00	\$4,504.78	\$5,300.00	\$795.22
The Races	\$0.00	\$1,934.34	\$0.00	(\$1,934.34)
Mystery Dinner	\$0.00	\$34.62	\$0.00	(\$34.62)
Tailgate	\$0.00	\$82.11	\$860.00	\$777.89
Offsite Lunches	\$0.00	\$748.04	\$1,200.00	\$451.96
Christmas Party	\$0.00	\$3,242.81	\$4,000.00	\$757.19
Camp Royal	\$0.00	(\$58.38)	\$0.00	\$58.38
Christmas Food Basket	\$0.00	\$2,000.00	\$0.00	(\$2,000.00)
Community Projects	\$0.00	\$0.00	\$1,000.00	\$1,000.00
Bullard Interact	\$0.00	\$0.00	\$200.00	\$200.00
SJM Interact	\$0.00	\$0.00	\$200.00	\$200.00
Youth Exchange	\$0.00	\$0.00	\$200.00	\$200.00
Paul Harris	\$0.00	\$0.00	\$400.00	\$400.00
Total Expenditure	\$2,806.78	\$37,983.27	\$37,700.00	(\$283.27)

Rotary Club of Fig Garden

Club Accounts

Income & Expenditure: Comparison to Budget to February 03

Printed 3/ 8/03

	Current Month	Year to Date	Budget to Date	Variance
Excess (Deficit)	(\$151.28)	\$14,946.57	\$11,420.00	\$4,093.11

FIG GARDEN ROTARY CLUB

FOUNDATION
BOARD OF DIRECTORS

-Regular Meeting: 19 March 2003:

-Members Present:

*Directors:

August Hioco
Matt Merzoian
Howard Reed
Steve Rontell
David Stepp

*Club Treasurer:

Scott Bristol

*President-Elect:

Rod Coburn

*President:

Eric Fogderude

*Secretary:

Doug Cords

*Others Present:

Past President John Heberger
Debra Coe

The meeting was called to concurrent order by President Eric Fogderude with the Regular Board Meeting of the Fig Garden Rotary Club in the Boardroom of the Stoughton Davidson Accountancy Corporation at 2530 West Shaw Lane, Suite 101, Fresno, California at 7:07 a.m.

*TREASURER'S REPORT:

Ill health precluded participation by Foundation Treasurer Fletcher. Because this marks two months without Financial Reports, President Eric will e-mail/fax/mail both sets of Financials (January and February) to Board Members as they become available from the Treasurer.

*ADJOURNMENT:: Concurrent With Regular Meeting, Adjourned At 8:56 a.m.

*NEXT MEETING: 16 April 2003

Respectfully Submitted By Doug Cords, Ph.D., Foundation Secretary.

FIG GARDEN ROTARY CLUB

BOARD OF DIRECTORS

*Regular Meeting: 16 April 2003:

-Members Present:

*Directors:

Daniel Bonyhadi
Jamie Franklin
August Hioco
Matt Merzoian
Howard Reed
Steve Rontell
Richard Saroyan

*President:

Eric Fogderude

*Treasurer:

Scott Bristol

*Foundation Treasurer:

Ron Fletcher

*Secretary:

Doug Cords

*Past President:

John Skewes

*President-Elect:

Rod Coburn

The meeting was called to order by President Eric Fogderude at 7:04 a.m. in the Boardroom of the Stoughton Davidson Accountancy Corporation at 2530 West Shaw Lane, Suite 101, Fresno, California 93711.

*INITIAL BUSINESS:

President Eric Fogderude re-nominated Director Daniel Bonyhadi to the Board, a result of business pressures necessitating his missing three Board Meetings. It was MSC to approve the re-nomination.

Note: Director David Stepp is disqualified from the Board due to his missing three meetings during this Rotary year.

*CONSENT ITEMS:

*Minutes Of The 19 March 2003 Regular Board Meeting
*Attendance For Month Of March 2003 = 75%
*Membership As Of 1 April 2003 = 105

It was MSC to approve the Consent Items as presented.

*TREASURER'S REPORT:

(Scott Bristol)

Scott reviewed current accounts, as follows:

*Cash: \$36,634.
*Morgan Stanley: 16,625.
*Members' Current Accounts: 16,735.
*Playland Note Receivable: 5,000.
*Totals: \$74,994.

*TREASURER'S REPORT, Continued:

Fine income will be posted this month. The Club is still comfortably running ahead of Budget.

President Eric sent out polite letters to members with accounts in arrears, to contact him and/or Scott Bristol to try to get all accounts paid in full before the end of this Rotary year.

It was MSC to approve the Treasurer's Report as presented.

*SECRETARY'S REPORT: (Doug Cords)

Due to attendance difficulties, member Rob Morello has been terminated from the Club. He has taken a new position with huge travel obligations. Rob noted to Director Daniel Bonyhadi he looked forward to returning to membership in a year.

Member Craig Gallego, owner of Hodge And Sons, lost both his tailor and only sales professional and is running his store alone. It was MSC to grant Craig an Excuse From Attendance Requirements for a period of 90 days.

The COG Leaders will return the Secretary to the E-mail list to denote Friday working assignments for ticket/raffle and badge box. COG Tony Carr is not meeting even minimum COG requirements. Mentor Norm Fletcher will be contacted to hopefully help rectify the situation, report from President Eric next month to the Board.

It was MSC to nominate Dr. Rod Coburn as the Club's first Official Delegate to the Rotary International 2003-2004 Convention in Brisbane, Australia. Secretary presented Rod with his official documentation. Fig Garden Rotary Club has one more delegate position open. President Eric will offer this slot to members, at a Friday meeting and in Avenues. Pending this outcome, next month the Board will assign our second voting slot.

District Attendance Figures for February were circulated. Our Club leads all local clubs in monthly average attendance.

-New Member Proposal-

DARRYL BOOTH

Decade Software Company

Sponsors Are August Hioco and Sasan Rahmatian
Membership Has Approved
Proposed Classification: Computers-Software Development

It was MSC to approve the Nomination. Secretary to forward immediately to Bob Bergin for Rotary Information.

*PRESIDENT-ELECT'S REPORT: (Rod Coburn)

Rod noted strong attendance interest for the upcoming Conference. Auction thank-you letters, bogged down with software, are going out shortly.

*PRESIDENT-ELECT'S REPORT, Continued:

A lengthy discussion ensued regarding what actual physical equipment the Club owns, specifically hardware and related items and exactly the location of each piece. Security, insurance and physical condition issues prompted the coverage of this topic. President Eric will report to the Board shortly on this important issue.

*PAST PRESIDENT'S REPORT: (John Skewes)

In the interest of time, John omitted his comments.

*PRESIDENT'S TIME: (Eric Fogderude)

The District Conference will be 16-18 May. President Eric offered a carpool for the Saturday events only, going and returning that same day.

25 April is the deadline to submit proposed modifications for the Rotary International Constitution.

Eric circulated the Harvest Report, our District Newsletter.

A thank you letter from Play It Safe International was circulated.

The Membership Roster is completed and will be available at the Club's next meeting, 2 May.

The new Blue Book Binders have arrived, putting into process the overall revision of our membership book.

It was MSC to move the amount of \$10,000. in Club Funds to the Foundation, for the Permanent Funds. Early-on in President Rod's year, this issue will be re-visited, with the hope of transferring more funds into the Permanent Funds account.

President Eric encouraged all Directors for next month's meeting to have a formal report prepared denoting key accomplishments this Rotary year and recommendations for next year.

*AVENUES OF SERVICE:

-Club Service: (Daniel Bonyhadi and August Hioco)

The Golf Day and COG Social will be held on 25 April. Upcoming events are a possible Mystery Dinner, Wrinkles and President Eric's Demotion Party.

Director August Hioco shared his genuine appreciation for the key leadership of his Co-Director Daniel Bonyhadi.

-Community Service: (Richard Saroyan and Steve Rontell)

It was MSC to allocate up to the sum of \$1,500. to help fund the purchase of a coin counting machine for the Leukemia and Lymphoma Society, per request through Dave Kyle of East Fresno Rotary, the Society's Director. Other funds are possibly available from local Rotary Clubs.

Note: Past-President J. T. Skewes took over the meeting in Eric's stead.

-Community Service, continued:

It was MSC to approve funding in the amount of \$2,500. for the Leadership Fresno project at the Marjoree Mason Center. Member Stacy Rianda is the point person. The funds will create a Self-Help Resource Center, with books and videos. President-Elect Rod requested that the Club receive appropriate signage in the Center to recognize our help.

There remain approximately \$8,000. of Community Service Funds. The next focus will be to identify a Fig Garden Rotary Club possible Centennial Project.

-Vocational Service: (Matt Merzoian)

The Camp Royal applications from Bullard High School are in and the Personal Interview process will be upcoming, Treasurer Scott Bristol asked to join the Selection Committee.

School Scholarships at Bullard High School, San Joaquin Memorial High School and Fresno City College are continuing.

-International Service: (Jamie Franklin and Howard Reed)

Howard is the point person for this next week's hosting of the Group Study Exchange Team from the country of Chile. They arrive on Saturday 19 April. Part of our responsibilities is to transport the members to the Conference.

Extensive discussions ensued regarding the country which will be the ultimate recipient of our Wheelchair Foundation gifts. Director Jamie Franklin has been in contact often with the Foundation, as well as other Rotarians who have experience with this venue. The countries of Ecuador and Costa Rica were identified and confirmed by Wheelchair International as being acceptable beneficiaries. After extensive discussion, it was MSC to identify Ecuador as our Club's first choice and to go forward.

*OLD BUSINESS:

The local clubs' Centennial Project, a Proposed Center on the San Joaquin River discussed last month, has been tabled due to regulatory issues.

*NEW BUSINESS:

The possible restoration of the Bullard High School Theater, probably named after our Club, will be investigated and reported on in the future.

*ADJOURNMENT: Adjourned by Past-President John Skewes at 8:41 a.m.

*NEXT MEETING: 21 May 2003

Respectfully Submitted By Doug Cords, Ph.D.

Rotary Club of Fig Garden

Club Accounts

Balance sheet for period ending 31 March 03

Printed 4/15/03

ACCUMULATED FUNDS

Club Funds

Balance at beginning of year	\$56,352.89
Excess (Deficit) for period	\$17,566.43
Balance to Date	\$73,919.32

TOTAL FUNDS	<u>\$73,919.32</u>
--------------------	--------------------

Represented by:

ASSETS

Checking Account-Cal Fed	\$36,634.23
Morgan Stanley Dean Witter	\$16,625.09
Member's Current Accounts	\$16,735.00
Note Rec - Playland	\$5,000.00
Total Assets	<u>\$74,994.32</u>

LIABILITIES

PHF Clearing	(\$425.00)
Woodward Park Bench Project	\$1,500.00
Total Liabilities	<u>\$1,075.00</u>

NET ASSETS	<u>\$73,919.32</u>
-------------------	--------------------

Rotary Club of Fig Garden

Club Accounts

Income & Expenditure: Current Month & Year to Date to March 03

Printed 4/15/03

	Current Month	Year to Date
INCOME		
Member Dues	\$250.00	\$27,125.00
Terminated Members	\$0.00	(\$125.00)
Admin Charge-New Members	\$155.00	\$475.00
Fines	\$0.00	\$11,462.50
Raffle	\$188.00	\$986.00
Interest	\$33.48	\$134.28
Roger Rockas	\$0.00	\$2,663.50
Retreat	\$0.00	\$3,901.00
Races	\$0.00	\$1,957.00
Tailgate	\$0.00	\$520.00
Offsite Lunches	\$480.00	\$1,212.00
Christmas Party	\$0.00	\$2,525.00
Gift Exchange/Toys for Tots	\$0.00	\$121.00
Auction	\$4,475.00	\$4,575.00
Miscellaneous Income	\$793.03	\$1,772.07
Total Income	\$6,374.51	\$59,304.35
EXPENDITURE		
R.I. Dues	\$0.00	\$5,616.75
District Dues	\$0.00	\$5,242.94
Supplies and Postage	\$111.00	\$1,705.70
Computer Expenses and Web Site	\$0.00	\$522.00
Officer Expense	\$0.00	\$3,997.01
Terminated Members	\$0.00	\$250.00
Miscellaneous Expense	\$0.00	\$1,628.78
Bank Charges	\$0.00	\$7.72
Lunch-Tornino's	\$432.50	\$1,263.00
Programs	\$0.00	\$200.00
Demotion Party	\$0.00	\$512.52
Banners, Badges, Pins	\$0.00	\$563.82
Hospitality and Fellowship	\$0.00	\$1,915.74
Rotary Information	\$0.00	\$62.47
Roger Rockas	\$0.00	\$2,550.00
Retreat	\$1,469.90	\$5,974.68
The Races	\$0.00	\$1,934.34
Mystery Dinner	\$0.00	\$34.62
Field Trips	\$793.03	\$793.03
Tailgate	\$0.00	\$82.11
Offsite Lunches	\$0.00	\$748.04
Christmas Party	\$0.00	\$3,242.81
Valentines Day	\$93.43	\$93.43
Auction	\$754.79	\$854.79
Camp Royal	\$0.00	(\$58.38)
Christmas Food Basket	\$0.00	\$2,000.00
Total Expenditure	\$3,654.65	\$41,737.92
Excess (Deficit)	\$2,719.86	\$17,566.43

Rotary Club of Fig Garden

Club Accounts

Income & Expenditure: Current Year vs Previous Year to March 03

Printed 4/15/03

	Month		Year to Date	
	Current Year	Previous Year	Current Year	Previous Year
INCOME				
Member Dues	\$250.00	\$0.00	\$27,125.00	\$27,557.50
Terminated Members	\$0.00	\$0.00	(\$125.00)	\$0.00
Admin Charge-New Members	\$155.00	\$0.00	\$475.00	\$720.00
Fines	\$0.00	\$5,157.25	\$11,462.50	\$15,644.75
Raffle	\$188.00	\$95.00	\$986.00	\$1,243.00
Interest	\$33.48	\$59.26	\$134.28	\$295.60
Demotion Party	\$0.00	\$0.00	\$0.00	\$60.00
Roger Rockas	\$0.00	\$0.00	\$2,663.50	\$0.00
Retreat	\$0.00	\$0.00	\$3,901.00	\$3,575.00
Races	\$0.00	\$0.00	\$1,957.00	\$2,188.00
Tailgate	\$0.00	\$0.00	\$520.00	\$700.00
Offsite Lunches	\$480.00	\$0.00	\$1,212.00	\$801.00
Christmas Party	\$0.00	\$0.00	\$2,525.00	\$3,600.00
Gift Exchange/Toys for Tots	\$0.00	\$0.00	\$121.00	\$0.00
Auction	\$4,475.00	\$5,720.00	\$4,575.00	\$6,235.00
Miscellaneous Income	\$793.03	\$40.00	\$1,772.07	\$1,719.96
Community Projects	\$0.00	\$0.00	\$0.00	\$2,500.00
Wheelchair Project	\$0.00	\$0.00	\$0.00	\$140.00
Paul Harris	\$0.00	\$0.00	\$0.00	\$315.00
Total Income	\$6,374.51	\$11,071.51	\$59,304.35	\$67,294.81
EXPENDITURE				
R.I. Dues	\$0.00	\$0.00	\$5,616.75	\$5,355.04
District Dues	\$0.00	\$0.00	\$5,242.94	\$5,647.68
Supplies and Postage	\$111.00	\$265.78	\$1,705.70	\$1,140.56
Computer Expenses and Web Site	\$0.00	\$0.00	\$522.00	\$0.00
Officer Expense	\$0.00	\$330.00	\$3,997.01	\$608.96
Terminated Members	\$0.00	\$0.00	\$250.00	\$2,530.00
Miscellaneous Expense	\$0.00	\$0.00	\$1,628.78	\$889.00
Bank Charges	\$0.00	\$0.00	\$7.72	\$7.48
Lunch-Tornino's	\$432.50	\$714.00	\$1,263.00	\$1,768.50
FGR Foundation	\$0.00	\$0.00	\$0.00	\$5,000.00
Programs	\$0.00	\$86.53	\$200.00	\$86.53
Demotion Party	\$0.00	\$0.00	\$512.52	\$329.41
Bulletin	\$0.00	\$0.00	\$0.00	\$359.85
Banners, Badges, Pins	\$0.00	\$0.00	\$563.82	\$779.02
Hospitality and Fellowship	\$0.00	\$302.89	\$1,915.74	\$2,135.55
Blue Book	\$0.00	\$34.00	\$0.00	\$987.07
Rotary Information	\$0.00	\$0.00	\$62.47	\$182.25
Roger Rockas	\$0.00	\$0.00	\$2,550.00	\$0.00
Retreat	\$1,469.90	\$300.00	\$5,974.68	\$4,660.47
The Races	\$0.00	\$0.00	\$1,934.34	\$2,080.22
Mystery Dinner	\$0.00	\$0.00	\$34.62	\$0.00
Field Trips	\$793.03	\$0.00	\$793.03	\$0.00
Tailgate	\$0.00	\$0.00	\$82.11	\$823.76
Offsite Lunches	\$0.00	\$0.00	\$748.04	\$839.87
Christmas Party	\$0.00	\$0.00	\$3,242.81	\$4,981.19
Valentines Day	\$93.43	\$0.00	\$93.43	\$151.45
Auction	\$754.79	\$3,760.00	\$854.79	\$4,478.26
Camp Royal	\$0.00	\$0.00	(\$58.38)	(\$66.83)
Christmas Food Basket	\$0.00	\$0.00	\$2,000.00	\$0.00
Community Projects	\$0.00	\$0.00	\$0.00	\$5,175.00
Youth Exchange	\$0.00	\$0.00	\$0.00	\$53.76

Rotary Club of Fig Garden

Club Accounts

Income & Expenditure: CurrentYear vs Previous Year to March 03

Printed 4/15/03

	Month		Year to Date	
	Current Year	Previous Year	Current Year	Previous Year
Paul Harris	\$0.00	\$0.00	\$0.00	\$1,500.00
Total Expenditure	\$3,654.65	\$5,793.20	\$41,737.92	\$52,484.05
Excess (Deficit)	\$2,719.86	\$5,278.31	\$17,566.43	\$14,810.76

Rotary Club of Fig Garden

Club Accounts

Income & Expenditure: Comparison to Budget to March 03

Printed 4/15/03

	Current Month	Year to Date	Budget to Date	Variance
INCOME				
Member Dues	\$250.00	\$27,125.00	\$28,000.00	(\$875.00)
Terminated Members	\$0.00	(\$125.00)	\$0.00	(\$125.00)
Admin Charge-New Members	\$155.00	\$475.00	\$900.00	(\$425.00)
Fines	\$0.00	\$11,462.50	\$15,000.00	(\$3,537.50)
Raffle	\$188.00	\$986.00	\$900.00	\$86.00
Interest	\$33.48	\$134.28	\$450.00	(\$315.72)
Roger Rockas	\$0.00	\$2,663.50	\$0.00	\$2,663.50
Retreat	\$0.00	\$3,901.00	\$3,800.00	\$101.00
Races	\$0.00	\$1,957.00	\$0.00	\$1,957.00
Tailgate	\$0.00	\$520.00	\$720.00	(\$200.00)
Offsite Lunches	\$480.00	\$1,212.00	\$1,350.00	(\$138.00)
Christmas Party	\$0.00	\$2,525.00	\$3,000.00	(\$475.00)
Gift Exchange/Toys for Tots	\$0.00	\$121.00	\$0.00	\$121.00
Auction	\$4,475.00	\$4,575.00	\$0.00	\$4,575.00
Miscellaneous Income	\$793.03	\$1,772.07	\$450.00	\$1,322.07
Total Income	\$6,374.51	\$59,304.35	\$54,570.00	\$4,734.35
EXPENDITURE				
R.I. Dues	\$0.00	\$5,616.75	\$5,800.00	\$183.25
District Dues	\$0.00	\$5,242.94	\$5,800.00	\$557.06
Supplies and Postage	\$111.00	\$1,705.70	\$1,350.00	(\$355.70)
Computer Expenses and Web Site	\$0.00	\$522.00	\$270.00	(\$252.00)
Officer Expense	\$0.00	\$3,997.01	\$950.00	(\$3,047.01)
Terminated Members	\$0.00	\$250.00	\$1,800.00	\$1,550.00
Miscellaneous Expense	\$0.00	\$1,628.78	\$900.00	(\$728.78)
Bank Charges	\$0.00	\$7.72	\$0.00	(\$7.72)
Dist Conf and Assembly	\$0.00	\$0.00	\$250.00	\$250.00
Lunch-Tornino's	\$432.50	\$1,263.00	\$1,575.00	\$312.00
Programs	\$0.00	\$200.00	\$450.00	\$250.00
Speakers	\$0.00	\$0.00	\$1,350.00	\$1,350.00
Demotion Party	\$0.00	\$512.52	\$0.00	(\$512.52)
Bulletin	\$0.00	\$0.00	\$900.00	\$900.00
Banners, Badges, Pins	\$0.00	\$563.82	\$675.00	\$111.18
Hospitality and Fellowship	\$0.00	\$1,915.74	\$3,375.00	\$1,459.26
Blue Book	\$0.00	\$0.00	\$675.00	\$675.00
Rotary Information	\$0.00	\$62.47	\$225.00	\$162.53
Membership	\$0.00	\$0.00	\$450.00	\$450.00
Roger Rockas	\$0.00	\$2,550.00	\$0.00	(\$2,550.00)
Retreat	\$1,469.90	\$5,974.68	\$5,300.00	(\$674.68)
The Races	\$0.00	\$1,934.34	\$0.00	(\$1,934.34)
Mystery Dinner	\$0.00	\$34.62	\$0.00	(\$34.62)
Field Trips	\$793.03	\$793.03	\$0.00	(\$793.03)
Tailgate	\$0.00	\$82.11	\$860.00	\$777.89
Offsite Lunches	\$0.00	\$748.04	\$1,200.00	\$451.96
Christmas Party	\$0.00	\$3,242.81	\$4,000.00	\$757.19
Valentines Day	\$93.43	\$93.43	\$0.00	(\$93.43)
Auction	\$754.79	\$854.79	\$600.00	(\$254.79)
Camp Royal	\$0.00	(\$58.38)	\$0.00	\$58.38
Christmas Food Basket	\$0.00	\$2,000.00	\$0.00	(\$2,000.00)
Community Projects	\$0.00	\$0.00	\$1,125.00	\$1,125.00
Bullard Interact	\$0.00	\$0.00	\$225.00	\$225.00
SJM Interact	\$0.00	\$0.00	\$225.00	\$225.00
Youth Exchange	\$0.00	\$0.00	\$225.00	\$225.00

Rotary Club of Fig Garden

Club Accounts

Income & Expenditure: Comparison to Budget to March 03

Printed 4/15/03

	Current Month	Year to Date	Budget to Date	Variance
Paul Harris	\$0.00	\$0.00	\$450.00	\$450.00
Total Expenditure	\$3,654.65	\$41,737.92	\$41,005.00	(\$732.92)
Excess (Deficit)	\$2,719.86	\$17,566.43	\$13,565.00	\$5,467.27

FIG GARDEN ROTARY CLUB
FOUNDATION
BOARD OF DIRECTORS

*Regular Meeting: 16 April 2003:

-Members Present:

*Directors:

Daniel Bonyhadi
Jamie Franklin
August Hioco
Matt Merzoian
Howard Reed
Steve Rontell
Richard Saroyan

*President:

Eric Fogderude

*Treasurer:

Scott Bristol

*Foundation Treasurer:

Ron Fletcher

*Secretary:

Doug Cords

*Past President:

John Skewes

*President-Elect:

Rod Coburn

The meeting was called to concurrent order by President Eric Fogderude with the Regular Board Meeting of the Fig Garden Rotary Club in the Boardroom of the Stoughton Davidson Accountancy Corporation at 2530 West Shaw Lane, Suite 101, Fresno, California at 7:04 a.m.

*TREASURER'S REPORT:

(Ron Fletcher)

Due to extenuating circumstances, a Treasurer's Report was not presented in the periods covering January and February. Ron presented those reports and covered key income and expenditure items.

Accounts:

*Unrestricted Funds:	\$113,052.
*Permanent Funds:	<u>126,773.</u>
*Totals:	\$239,825.

Ron reviewed items of income and expenses for the month of March. The recap of Auction income and costs reveals an approximate net of \$53,000-54,000.

Next month, an update on Foundation Investments will be presented. It was MSC to approve the Treasurer's Report as presented.

The next Investment Committee Meeting is on May 13, 2003.

*NEXT MEETING: 21 May 2003

*ADJOURNED BY PRESIDENT ERIC FOGDERUDE, CONCURRENT WITH REGULAR MEETING, AT 8:41 a.m.

Respectfully Submitted By Doug Cords, Ph.D., Foundation Secretary.

FIG GARDEN ROTARY FOUNDATION
STATEMENT OF REVENUE, EXPENSES AND CASH BALANCES
JANUARY 31, 2003

	TOTAL FYE	BUDGET	MONTH	MONTH	MONTH	MONTH	MONTH	MONTH	MONTH	MONTH	MONTH	MONTH	MONTH	MONTH	MONTH	MONTH	MONTH	TOTAL FYE
	02/002	03/003	7/31/02	8/31/02	9/30/02	10/31/02	11/30/02	12/31/02	1/31/03	2/29/03	3/31/03	4/30/03	5/31/03	6/30/03	7/31/03	8/30/03	9/30/03	02/002
REVENUE:																		
AUCTION-2003	\$0	360,000																\$0
AUCTION-2002	67,500			472														67,972
AUCTION-2001	4,150																	4,150
5TH AVE FUNDRAISER	0	10,000																0
DONATIONS	12,702			400	3,400	2,125	220	345	17,505	3,000								17,505
CLEAR CHNL.COM - JAZZCOO	9,000	10,000	11,094	2,500					10,490									10,490
EARNINGS - FOUNDATION	1,810	1,500	111	95	89	4	4	3	13,084	324								13,084
EARNINGS - PERM FUND	2,463	10,000	40	75	150				305									305
CONTRIB - FGR	18,600	0							0									0
CONTRIB - PERM. FUND	0	5,000							0									0
UNREAL GAIN-PERM. FUND	(24,484)		(5,453)	685	(5,436)	(2,980)	3,246	410	(1,420)									(10,654)
	98,518	59,500	5,352	4,003	(1,361)	(379)	3,472	764	19,630	0	0	0	0	0	0	0	0	32,628
EXPENSES:																		
ADMINISTRATIVE	13	105		25														
AUCTION - 2003	1,000	15,000																1,000
AUCTION - 2002	18,089			450	317		80											18,856
AUCTION - 2001	2,086																	2,086
5TH AVE FUNDRAISER	0																	0
DONATIONS	7,805						250		25									7,830
AVENUES OF SERVICE:																		
COMMUNITY SERVICE	53,725	50,000		6,693	1,350		3,014	3,500										64,179
VOCATIONAL SERVICE	0	5,000																5,000
INTERNATIONAL SERVICE	0	5,000		560														5,560
VOCATIONAL SCHOLARSHIP	5,000	0																5,000
R.I. - POLIO PLUS	0	10,000																10,000
CONTRIB - PERM. FUND	0	5,000																5,000
	37,811	90,100	0	25	7,700	1,667	0	5,344	3,525	0	0	0	0	0	0	0	0	16,284
EXCESS OF REVENUES	708	\$6,400	\$5,352	\$3,063	(\$9,034)	(\$2,046)	\$3,472	(\$2,580)	\$16,165	\$0	\$0	\$0	\$0	\$0	\$0	\$0	\$0	15,762
OVER EXPENSES																		
BEG. CASH BALANCE	234,983																	234,983
ENDING CASH BALANCE	\$235,691																	\$235,691
RESTRICTED AMOUNTS																		
Paul Harris																		
Paul Harris																		
REMAINING UNDESIGNATED																		
COMM SER FOR 2001-02																		
PLAY IT SAFE																		
HOLIDAY GIFT BASKETS																		
EXPENDITURES ENCUMBERED																		
Expire 12/31/02 - 2002 AURBON																		
WASHINGTON MUTUAL CHECK	\$7,406																	\$7,406
DWR - LIQUID ASSET ACCT	30,928																	30,928
PERMANENT FUND	138,655																	138,655
	\$235,691																	\$235,691
DEFOSITS																		
PAUL HARRIS 260																		
5TH AVE 17505																		
WHEELCHAIR 3350																		
OTHER ENCUMBERED FUNDS																		
INTERNATIONAL SERVICE																		
EXCHANGE STUDENTS-\$2800																		
WHEELCHAIR \$18,000																		
WASHINGTON MUTUAL CHECKING																		
FOUNDATION RESERVE ACCOUNT UBS PW																		
PERMANENT FUND (ENDOWMENT) UBS PW																		
TOTAL																		

FIG GARDEN ROTARY FOUNDATION
STATEMENT OF REVENUE, EXPENSES AND CASH BALANCES
FEBRUARY 28, 2003

	TOTAL FYE	BUDGET	MONTH	MONTH	MONTH	MONTH	MONTH	MONTH	MONTH	MONTH	MONTH	MONTH	MONTH	MONTH	TOTAL FYE
	6/30/02	6/30/03	7/3/02	8/3/02	10/3/02	11/3/02	12/3/02	1/3/03	2/28/03	3/31/03	4/30/03	5/31/03	6/30/03	6/30/03	6/30/03
REVENUE:															
AUCTION-2003	\$0	\$60,000													\$0
AUCTION-2002	67,908														67,908
AUCTION-2001	4,120														4,120
5TH AVE FUNDRAISER	0	10,000													0
DONATIONS	12,702														12,702
CLEAR CHNL.COM - JAZZCOO	8,000														8,000
EARNINGS - FOUNDATION	1,810														1,810
EARNINGS - PERM. FUND	2,483														2,483
CONTRIB. - FGR	18,000														18,000
CONTRIB. - PERM. FUND	0														0
UNREAL GAIN-PERM. FUND	(24,424)														(24,424)
	38,517	96,500	1,952	4,008	(1,381)	(378)	3,472	781	19,880	21,910	0	0	0	0	59,845
EXPENSES:															
ADMINISTRATIVE	10	100													10
AUCTION - 2003	1,600	15,000													1,600
AUCTION - 2002	14,889														14,889
AUCTION - 2001	2,636														2,636
5TH AVE FUNDRAISER	0														0
DONATIONS	7,305														7,305
AVENUES OF SERVICE:															
COMMUNITY SERVICE	53,725	50,000													53,725
VOCATIONAL SERVICE	0	5,000													0
INTERNATIONAL SERVICE	0	5,000													0
VOCATIONAL SCHOLARSHIP	5,000	0													5,000
R. J. - POLIO PLUS	10,070	10,070													10,070
CONTRIB. - PERM. FUND	0	5,000													0
	87,811	80,100	0	26	7,703	1,667	0	3,344	9,525	42,463	0	0	0	0	58,717
EXCESS OF REVENUES	708	\$6,400	\$5,852	\$9,983	(\$9,054)	(\$2,046)	\$3,472	(\$2,560)	\$18,155	(\$30,534)	\$0	\$0	\$0	\$0	(\$4,772)
OVER EXPENSES															
BEG. CASH BALANCE	254,583														254,583
ENDING CASH BALANCE	\$208,901														\$208,901
RESTRICTED AMOUNTS															
Paul Harris															
REMAINING UNDESIGNATED															
COMM SER. FOR 2001-02															
HOLIDAY GFT BASKETS															
PLAY & SALS															
WASHINGTON MUTUAL CHECKING															
FOUNDAIOR RESERVE ACCOUNT															
PERMANENT FUND															
PERMANENT FUND (ENDOWMENT)															
WASHINGTON MUTUAL CHECKING															
FOUNDAIOR RESERVE ACCOUNT															
PERMANENT FUND (ENDOWMENT)															
UNREAL GAIN-PERM. FUND															
TOTAL	\$208,901														\$208,901

DEPOSITS															
PAUL HARRIS 680															
5TH AVE 16237															
WHEELCHAIR 36375															
OTHER ENCUMBERED FUNDS															
INTERNATIONAL SERVICE															
EXCHANGE STUDENTS-\$2600															
BEG. CASH BALANCE															
ENDING CASH BALANCE															
WASHINGTON MUTUAL CHECK															
DWR - LIQUID ASSET ACCT															
PERMANENT FUND															
PERMANENT FUND (ENDOWMENT)															
WASHINGTON MUTUAL CHECKING															
FOUNDAIOR RESERVE ACCOUNT															
PERMANENT FUND (ENDOWMENT)															
UNREAL GAIN-PERM. FUND															
TOTAL															

**FIG GARDEN ROTARY FOUNDATION
CHARITY AUCTION
STATEMENT OF INCOME
April 10, 2003**

REVENUES

Ticket Sales - Paid	\$6,500.00
Ticket Sales A/R (Billed)	\$4,475.00
Ticket Raffle	\$3,010.00
Merchandise Paid	\$49,922.00
Direct Donations	\$5,450.00
<u>TOTAL REVENUE</u>	<u>\$69,357.00</u>

EXPENSES

Facility and Food Cost	\$13,107.70
Decorations	\$349.48
Supplies	\$1,181.80
Printing	
Tickets, Catalogs, Bid Sheets, gift certificates	\$350.87
Merchant Discount/Credit Cards	\$1,176.99
Sound System	\$50.00
Raffle	\$0.00
Lunch & Other Foods	\$363.24
Flowers (Carnations)	\$272.28
Other Misc	
San Joaquin Memorial Interact	\$605.00
Bullard Interact	\$202.00
<u>TOTAL EXPENSES</u>	<u>\$17,659.36</u>

NET INCOME **\$51,697.64**

Prepared by Ron Fletcher, Foundation Treasurer

10-Apr-03

FIG GARDEN ROTARY FOUNDATION
St. Patrick's Day Charity Auction
Comparative Statement of Income
 As of April 10, 2003

	2003	2002	2001	2000	1999	1998	1997	1996	1995	1994	1993	1992	1991
	Auction	Auction	Auction	Auction	Auction	Auction	Auction	Auction	Auction	Auction	Auction	Auction	Auction
Revenue													
Ticket Sales - Paid	\$6,500	\$7,315	\$4,500	\$5,000	\$3,400	\$4,230	\$2,198	\$7,130	\$7,102	\$7,130	\$7,740	\$5,713	\$7,573
- AVR	4,475	5,350	4,460	4,500	2,880	0	1,206	0	560	-	-	-	-
	10,975	12,665	8,960	9,500	6,280	4,230	3,404	7,130	7,662	7,130	7,740	5,713	7,573
Ticket Raffle	3,010	3,025	3,020	2,828									
Merchandise - Paid	49,922	49,807	47,015	44,462	36,600	42,816	42,355	38,169	41,808	43,860	48,248	46,425	39,375
- AVR	0	0	0	780	850	0	0	0	1,237	-	-	-	-
	49,922	49,807	47,015	45,242	37,450	42,816	42,355	38,169	43,045	43,860	48,248	46,425	39,375
Donations	5450	3725	2915	6011				200	200				
Bedroom Set - \$50/member	0	5,500	0	0	0	0	0	0	0				
Total Revenue	69,357	74,722	61,910	63,581	43,730	47,046	45,759	45,299	50,707	50,990	55,988	52,138	46,948
Expenses													
Facility and Food Cost	13,108	12,658	11,044	10,288	6,724	9,914	8,302	8,490	9,495	8,260	7,203	7,577	10,028
Entertainment	0	0	100	100	200		0	750	300	250	275	-	250
Auctioneer	0	0	0	0	0	250	250	350	250	250	250	-	-
Decorations	350	332	0	0	804	1,198	845	847	1,392	1,376	653	450	1,353
Supplies	1,182	932	710	264	223	141	285	502	1,193	151	926	1,163	692
Printing - Tickets	351	0	288	0	261		308	312	302	302	338	307	218
- Catalogs	0	0	0	0	1,349	1,389	1,322	1,272	1,454	1,325	1,299	377	1,583
- Bid Sheets & Gift Cards	0	0	0	90			376	409	356	-	300	-	264
Merchant Disc. (Credit Cards)	1,177	816	734	767	687	672	799	580	646	664	636	569	-
Sound System	50						183			105	146		
Raffle	0	0	201	0	0	70	0	0	50	15	50		
Lunch & Other food	353	55	342	209	405	328	205	274	343	456	128	174	334
Flowers (Carnations)	272									79	215	108	
In-Put Personnel	0	0	0	0	5								
Batteries - Lights for silent auction	0	0	347	39									
Other Misc - inc- Interact Clubs	807	730	175	105	1,681	1,257	0	15	71	186	86	125	178
Total Expenses	17,650	15,513	13,941	11,862	12,339	15,219	12,875	13,874	15,862	13,419	12,505	10,914	15,300
Before Car Raffle	51,697	59,209	47,969	51,719	31,391	31,827	32,884	31,425	34,855	37,571	43,483	41,224	31,648
Car Raffle Net Proceeds	0	0	0	0	880	26,392	12,910					8796	13,525
Net Income	\$51,697	\$59,209	\$47,969	\$51,719	\$32,271	\$58,219	\$45,794	\$31,425	\$34,855	\$37,571	\$43,483	\$50,020	\$45,173

Fig Garden Rotary Endowment Account

Asset Allocation		
US Large Co. Equity	\$ 22,642.50	17.86%
US Med/Sm Co. Equity	\$ 22,671.63	17.88%
Balanced	\$ -	%
Int'l Equity	\$ 13,451.36	10.61%
Int'l Fixed Income	\$ -	0.00%
US Fixed Income	\$ 51,635.90	40.73%
Cash/Money Market	\$ 16,372.06	12.91%
	\$ 126,773.45	100.00%

Account Allocation

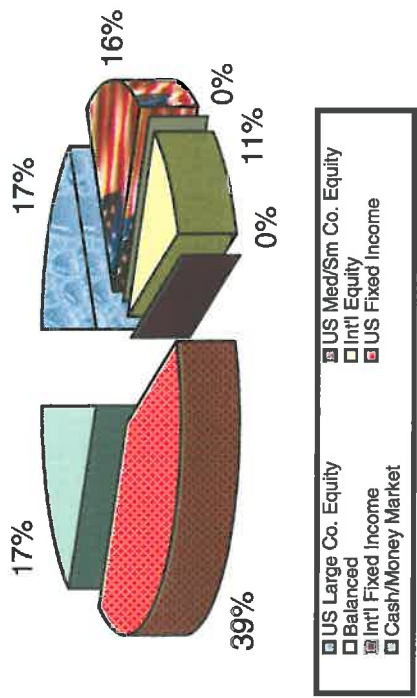

- US Large Co. Equity
- Balanced
- Int'l Equity
- US Fixed Income
- Cash/Money Market
- US Med/Sm Co. Equity
- Int'l Fixed Income

Investment Holdings

as of 3/31/03

	Cost Basis	Value Jan 01, 2003	Value 3/31/2003	% Chg from 1/1/2003
US Large Co. Equity:				
Income Fund of America	\$ 11,107.99	\$ 10,417.91	\$ 11,164.02	7.16%
Pimco Value Fund	\$ 11,979.65	\$ 11,195.52	\$ 11,478.48	2.53%
US Med/Sm Co. Equity:				
Liberty Acorn Fund	\$ 11,094.31	\$ 10,415.86	\$ 11,152.68	7.07%
Pimco Small Cap Value	\$ 11,990.29	\$ 11,037.68	\$ 11,518.95	4.36%
Balanced:				
Int'l Equity				
Templeton Foreign	\$ 14,730.49	\$ 13,777.98	\$ 13,451.36	-2.37%
US & Int'l Fixed Income:				
CD Independent Bank 2% due 10/23/03 *	\$ 12,973.87	\$ 12,916.93	\$ 12,967.24	0.39%
CD Discover Bank 2.5% due 11/08/04 *	\$ 12,000.00	\$ 12,043.08	\$ 12,094.32	0.43%
CD Key Bank & Trust 3.1% due 11/08/05 *	\$ 13,000.00	\$ 13,123.76	\$ 13,245.05	0.92%
CD Pan American Bank 3.65% due 10/30/06 *	\$ 12,930.84	\$ 13,185.38	\$ 13,329.29	1.09%
Cash/Money Market:				
Money Market	\$ 16,372.06	\$ 21,449.98	\$ 16,372.06	
TOTAL PORTFOLIO	\$ 128,179.50	\$ 129,564.08	\$ 126,773.45	-2.15%
Foundation Account Value				\$ 75,556.13



Paul Sahota - Financial Advisor

FIG GARDEN ROTARY CLUB

BOARD OF DIRECTORS

SPECIAL MEETING: 13 June 2003 -

Due notice was sent to Directors via fax and mail. The following were present:

Daniel Bonyhadi	August Hioco
Scott Bristol	Matt Merzoian
Doug Cords	Steve Rontell
Ron Fletcher	Richard Saroyan
Jamie Franklin	Dave Stepp

President Eric Fogderude established a quorum and called the meeting to order at 1:35 p.m. at the TorNino's Restaurant, Fresno, California.

Order Of Business:

It was MSC to declare the Club "Dark" on Friday, 4 July 2003. Secretary to notify TorNino's and provide a Make-Up Sheet for Visitors.

NEW MEMBER PROPOSAL:

Ted Fleener

General Manager,
Fresno Mitsubishi

Proposors: John Heberger and Mary Lou Gunn

Membership has approved.

Proposed Classification: Automotive Industry: Sales Management

It was MSC to approve the Nomination. Secretary to forward immediately to Rotary Information.

Director Dave Stepp polled the Board regarding the feasibility of a Field Trip (courtesy of COG Tony Carr) to the Fresno Heart Hospital on 1 August. It was enthusiastically supported. Dave to notify the Program Chair, AVENUES Bulletin and Judy Perkins at TorNino's.

The meeting was adjourned at 1:40 p.m.

Respectfully Submitted By Doug Cords, Ph.D., Club Secretary

FIG GARDEN ROTARY CLUB

BOARD OF DIRECTORS

*Regular Meeting - 21 May 2003:

*Members Present:

*Directors:

Daniel Bonyhadi
Jamie Franklin
August Hioco
Matt Merzoian
Howard Reed
Steve Rontell
Richard Saroyan
David Stepp

*Foundation Treasurer:

Ron Fletcher

*Past President:

John Skewes

*President-Elect:

Rod Coburn

*Others Present:

Steve Wilson
Jay Roll
Mike Gerardi
Tony Carr

*President:

Eric Fogderude

*Secretary:

Doug Cords

*Treasurer:

Scott Bristol

**Special Guest: **

Paul Sahota, UBS
Paine Webber

The meeting was called to order by President Eric Fogderude at 7:03 a.m. in the Boardroom of the Stoughton Davidson Accountancy Corporation at 2530 West Shaw Lane, Fresno, California 93711 (Suite # 101).

*INITIAL BUSINESS:

President Eric Fogderude re-nominated Director David Stepp to the Board, a result of business/travel pressures necessitating his missing three Board meetings, It was MSC to approve the re-nomination.

*CONSENT ITEMS:

*Minutes Of The 16 April 2003 Regular Board Meeting		
*Attendance For Month Of April, 2003	=	76%
*Membership As Of 1 May 2003	=	104

It was MSC to approve the Consent Items as presented.

*TREASURER'S REPORT:

(Scott Bristol)

Scott reviewed Current Assets, as follows:

*Cal Fed:	\$12,149.
*Morgan Stanley	26,636.
*Members' Accounts:	22,316.
*Playland Note:	5,000.
*Totals:	<u>\$66,101.</u>

*TREASURER'S REPORT, Continued:

The only major Current Liability is the Woodward Park Bench Project, in the amount of \$1,500.; this was a carryover from President John Skewes' year, to be used for a bench to honor deceased Club members. President-Elect Coburn would like to retain this line item for use as "seed money" for next year, as a Platform Plank of the Rotary year.

Scott then reviewed with the Board Income and Expenses, both Year To Date Compared To Budget And Last Year and Month-Ended.

It was MSC to approve the Treasurer's Report as presented.

*SECRETARY'S REPORT: (Doug Cords)

Per last month's Board Meeting, the Club is entitled to voting delegates totaling two at the Rotary International Convention. President Eric invited members to apply from the Podium at a recent meeting, and Avenues carried a like notice. No one came forward to make the request. It was MSC to nominate Dr. Rod Coburn as the Proxy for the second vote. Secretary to complete the paperwork and deliver to President-Elect Rod.

Attendance Issues: as is usual during the end of any six-month attendance period, several members are "on the bubble" with regard to either the 60% attendance requirement overall or the 30% home club rule. Secretary contacts personally each member, encouraging make-ups to avoid problems later on. It is interesting to note that several members who have problems with attendance also have financial issues with the Club.

The resignation of Wink Chase, who has relocated to Southern California, has been received and will be forwarded to Rotary International.

The Secretary circulated a recent Fortune magazine article lauding Rotary's "Polio Plus" program.

COG Fernando Morales has been terminated, due to unresolved attendance issues and an apparent disinterest in remaining in Fig Garden Rotary Club.

New Member Pipeline: Darryl Booth, sponsored by August Hioco and Sasan Rahmatian, was published on 15 May. the 7-Day Notice is now in effect. Darryl works at Decade Software. Pending no communications regarding the notice period, he will be inducted into the club on 30 May.

There are no new member proposals this month.

*PRESIDENT-ELECT'S REPORT: (Rod Coburn)

Rod verified that final figures for the Auction disclose that the approximate net is in the low \$50,000's.

Rod and President Eric attended the District Conference, wherein the Club was recognized for a Polio Plus Award.

Bullard High School has noted it will accept a total of only two Rotary Exchange Students for the coming year, a possible problem with our sponsorship. Rod will stay on top of this. The CV's of the Inbound and Outbound Exchange Student nominees were circulated for review.

*PAST PRESIDENT'S REPORT: (John Skewes)

John commended President Eric for a job well done. The Board expressed its sincere thanks to John for this year's leadership and wise counsel as a former President.

*PRESIDENT'S TIME: (Eric Fogderude)

In the July Board meeting, Eric will present an update of the computer hardware/equipment status and recommendations for utilization and storage.

It was MSC to utilize \$10,000. from "The Night On Fifth Avenue" fundraiser, per previous agreement, as a partial disposition of funds generated. This funding will go to Paul Harris Funding and will put the Club ahead of its commitments for this Rotary year.

The theme for this year's Demotion Party will be "25th Anniversary Of Fig Garden Rotary" Club. The Sanger Club is celebrating this year its 50th anniversary; Director August Hioco, who will attend the Club's fete, will pass along our club's congratulations for five decades of service.

Eric concluded his report by offering his sincere appreciation to each Board Member for contributions made during this year. At the 20 June meeting, he asked each to attend, to receive Club laudits and special recognition for jobs well accomplished.

*AVENUES OF SERVICE:

-Club Service: (Daniel Bonyhadi and August Hioco)

The successful Mystery Dinner, chaired by Steve Wilson, was held on 16 May. Harvey Armas is handling details and planning for the upcoming Demotion Party.

The Club enjoyed 15 events total so far this year.

-Community Service: (Richard Saroyan and Steve Rontell)

It was MSC to allocate the sum of \$3,800. for the "Unfolding Hearts" program for terminally ill children, for the purchase/assembling of educational kits.

It was MSC to allocate the sum of \$1,000. for the Duncan Polytechnic High School's construction management program, to purchase a unit of framing lumber.

It was MSC to target as the Club's "Centennial Project" the refurbishing of selected elements of the Theater on the campus of Bullard High School. President-Elect Rod noted this will provide naming rights, an opportunity to involve Interact members, a hands-on opportunity and provide a huge community service. The program in its entirety perhaps may take two years.

Richard and Steve expressed appreciation to the diligent and dedicated members who volunteered for the Community Service Committee this year. Steve also thanked the Saroyans for their special hospitality in their home, at each month's meeting.

-Vocational Service:

(Dave Stepp and Matt Merzoian)

The Directors noted that the Scholarship Program at San Joaquin Memorial High School is completed, with students recently visiting the Club to be awarded their funding.

The students from Bullard High School will come to the Club on 30 May.

(Editorial Note: in contrast to previous Board discussions regarding the (-) with the practice, checks for students are still made payable to the individual rather than to the school to be attended)

Camp Royal will again be staffed for a dinner and volunteers were solicited. Jim Gibbs in handling the selection of attendees through Bullard High School.

-International Service:

(Jamie Franklin and Howard Reed)

The contact for the Wheelchair Project in Quito, Ecuador is doing a superb job thus far, working to handle logistics between the Wheelchair Foundation, the Club and the manufacturing entity in China. October is the hoped-for delivery timeframe.

*OLD BUSINESS:

Treasurer Scott Bristol reviewed the "Aged Trial Balance" of member receivables, especially those more than 120 days in arrears. President Eric's letters have accomplished some payments. Several members have accrued very large past-due balances and this situation must be addressed.

*NEW BUSINESS:

Jamie Franklin noted that the next Auction will be again held at Casablanca, on 27 March 2004. He will be accepting Auction Chair Nominations.

Dr. Rod Coburn intends to host a Board Retreat in June, after his return from the RI Convention.

*ADJOURNMENT: President Eric adjourned the meeting at 8:31 a.m.

*NEXT MEETING: 16 July 2003 At Stoughton Davidson Accountancy Corporation

(Note: No June Board Meeting/Per Prior Board Motion)

RESPECTFULLY SUBMITTED BY DOUG CORDS, Ph.D., CLUB SECRETARY.

Rotary Club of Fig Garden

Club Accounts

Balance sheet for period ending 30 April 03

Printed 5/16/03

ACCUMULATED FUNDS

Club Funds

Balance at beginning of year	\$56,352.89
Excess (Deficit) for period	\$8,674.56
Balance to Date	\$65,027.45

TOTAL FUNDS	<u>\$65,027.45</u>
--------------------	--------------------

Represented by:

ASSETS

Checking Account-Cal Fed	\$12,149.01
Morgan Stanley Dean Witter	\$26,636.50
Member's Current Accounts	\$22,316.94
Note Rec - Playland	<u>\$5,000.00</u>
Total Assets	<u>\$66,102.45</u>

LIABILITIES

PHF Clearing	(\$425.00)
Woodward Park Bench Project	<u>\$1,500.00</u>
Total Liabilities	<u>\$1,075.00</u>

NET ASSETS	<u>\$65,027.45</u>
-------------------	--------------------

Rotary Club of Fig Garden

Club Accounts

Income & Expenditure: Current Month & Year to Date to April 03

Printed 5/16/03

	Current Month	Year to Date
INCOME		
Member Dues	\$0.00	\$27,125.00
Terminated Members	\$0.00	(\$125.00)
Admin Charge-New Members	\$0.00	\$475.00
Fines	\$0.00	\$17,093.75
Raffle	\$0.00	\$986.00
Interest	\$11.41	\$145.69
Roger Rockas	\$0.00	\$2,663.50
Retreat	\$0.00	\$3,901.00
Races	\$0.00	\$1,957.00
Tailgate	\$0.00	\$520.00
Offsite Lunches	\$0.00	\$1,212.00
Christmas Party	\$0.00	\$2,525.00
Gift Exchange/Toys for Tots	\$0.00	\$121.00
Auction	(\$50.00)	\$4,525.00
Miscellaneous Income	\$0.00	\$1,934.57
Total Income	(\$38.59)	\$65,059.51
EXPENDITURE		
R.I. Dues	\$0.00	\$5,616.75
District Dues	\$0.00	\$5,242.94
Supplies and Postage	\$0.00	\$1,705.70
Computer Expenses and Web Site	\$0.00	\$522.00
Officer Expense	\$0.00	\$3,997.01
Terminated Members	\$0.00	\$250.00
Miscellaneous Expense	\$0.00	\$1,628.78
Bank Charges	\$5.40	\$13.12
Lunch-Tornino's	\$0.00	\$1,263.00
FGR Foundation	\$10,000.00	\$10,000.00
Programs	\$0.00	\$200.00
Demotion Party	\$0.00	\$512.52
Banners, Badges, Pins	\$0.00	\$563.82
Hospitality and Fellowship	\$1,790.13	\$3,705.87
Blue Book	\$1,821.52	\$1,821.52
Rotary Information	\$0.00	\$62.47
Roger Rockas	\$0.00	\$2,550.00
Retreat	\$0.00	\$5,974.68
The Races	\$0.00	\$1,934.34
Mystery Dinner	\$0.00	\$34.62
Field Trips	\$579.98	\$1,373.01
Tailgate	\$0.00	\$82.11
Offsite Lunches	\$0.00	\$748.04
Christmas Party	\$0.00	\$3,242.81
Valentines Day	\$0.00	\$93.43
Auction	\$0.00	\$854.79
Camp Royal	\$0.00	(\$58.38)
Christmas Food Basket	\$0.00	\$2,000.00
Paul Harris	\$450.00	\$450.00
Total Expenditure	\$14,647.03	\$56,384.95
Excess (Deficit)	(\$14,685.62)	\$8,674.56

Rotary Club of Fig Garden

Club Accounts

Income & Expenditure: Current Year vs Previous Year to April 03

Printed 5/16/03

	Month		Year to Date	
	Current Year	Previous Year	Current Year	Previous Year
INCOME				
Member Dues	\$0.00	\$0.00	\$27,125.00	\$27,557.50
Terminated Members	\$0.00	\$0.00	(\$125.00)	\$0.00
Admin Charge-New Members	\$0.00	\$0.00	\$475.00	\$720.00
Fines	\$0.00	\$0.00	\$17,093.75	\$15,644.75
Raffle	\$0.00	\$0.00	\$986.00	\$1,243.00
Interest	\$11.41	\$0.00	\$145.69	\$295.60
Demotion Party	\$0.00	\$0.00	\$0.00	\$60.00
Roger Rockas	\$0.00	\$0.00	\$2,663.50	\$0.00
Retreat	\$0.00	\$0.00	\$3,901.00	\$3,575.00
Races	\$0.00	\$0.00	\$1,957.00	\$2,188.00
Tailgate	\$0.00	\$0.00	\$520.00	\$700.00
Offsite Lunches	\$0.00	\$375.00	\$1,212.00	\$1,176.00
Christmas Party	\$0.00	\$0.00	\$2,525.00	\$3,600.00
Gift Exchange/Toys for Tots	\$0.00	\$0.00	\$121.00	\$0.00
Auction	(\$50.00)	\$0.00	\$4,525.00	\$6,235.00
Miscellaneous Income	\$0.00	\$2,100.00	\$1,934.57	\$3,819.96
Community Projects	\$0.00	\$0.00	\$0.00	\$2,500.00
Wheelchair Project	\$0.00	\$0.00	\$0.00	\$140.00
Paul Harris	\$0.00	\$0.00	\$0.00	\$315.00
Total Income	(\$38.59)	\$2,475.00	\$65,059.51	\$69,769.81
EXPENDITURE				
R.I. Dues	\$0.00	\$0.00	\$5,616.75	\$5,355.04
District Dues	\$0.00	\$0.00	\$5,242.94	\$5,647.68
Supplies and Postage	\$0.00	\$0.00	\$1,705.70	\$1,140.56
Computer Expenses and Web Site	\$0.00	\$0.00	\$522.00	\$0.00
Officer Expense	\$0.00	\$1,200.00	\$3,997.01	\$1,808.96
Terminated Members	\$0.00	\$0.00	\$250.00	\$2,530.00
Miscellaneous Expense	\$0.00	\$112.19	\$1,628.78	\$1,001.19
Bank Charges	\$5.40	\$0.00	\$13.12	\$7.48
Dist Conf and Assembly	\$0.00	\$100.00	\$0.00	\$100.00
Lunch-Tornino's	\$0.00	\$0.00	\$1,263.00	\$1,768.50
FGR Foundation	\$10,000.00	\$0.00	\$10,000.00	\$5,000.00
Programs	\$0.00	\$0.00	\$200.00	\$86.53
Demotion Party	\$0.00	\$0.00	\$512.52	\$329.41
Bulletin	\$0.00	\$0.00	\$0.00	\$359.85
Banners, Badges, Pins	\$0.00	\$0.00	\$563.82	\$779.02
Hospitality and Fellowship	\$1,790.13	\$130.00	\$3,705.87	\$2,265.55
Blue Book	\$1,821.52	\$0.00	\$1,821.52	\$987.07
Rotary Information	\$0.00	\$0.00	\$62.47	\$182.25
Roger Rockas	\$0.00	\$0.00	\$2,550.00	\$0.00
Retreat	\$0.00	\$0.00	\$5,974.68	\$4,660.47
The Races	\$0.00	\$0.00	\$1,934.34	\$2,080.22
Mystery Dinner	\$0.00	\$0.00	\$34.62	\$0.00
Field Trips	\$579.98	\$0.00	\$1,373.01	\$0.00
Tailgate	\$0.00	\$0.00	\$82.11	\$823.76
Offsite Lunches	\$0.00	\$356.00	\$748.04	\$1,195.87
Christmas Party	\$0.00	\$0.00	\$3,242.81	\$4,981.19
Valentines Day	\$0.00	\$0.00	\$93.43	\$151.45
Auction	\$0.00	\$0.00	\$854.79	\$4,478.26
Camp Royal	\$0.00	\$0.00	(\$58.38)	(\$66.83)
Christmas Food Basket	\$0.00	\$0.00	\$2,000.00	\$0.00
Community Projects	\$0.00	\$0.00	\$0.00	\$5,175.00

Rotary Club of Fig Garden

Club Accounts

Income & Expenditure: CurrentYear vs Previous Year to April 03

Printed 5/16/03

	Month		Year to Date	
	Current Year	Previous Year	Current Year	Previous Year
Bullard Interact	\$0.00	\$500.00	\$0.00	\$500.00
SJM Interact	\$0.00	\$500.00	\$0.00	\$500.00
Youth Exchange	\$0.00	\$0.00	\$0.00	\$53.76
Paul Harris	\$450.00	\$0.00	\$450.00	\$1,500.00
Total Expenditure	\$14,647.03	\$2,898.19	\$56,384.95	\$55,382.24
Excess (Deficit)	(\$14,685.62)	(\$423.19)	\$8,674.56	\$14,387.57

Rotary Club of Fig Garden

Club Accounts

Income & Expenditure: Comparison to Budget to April 03

Printed 5/16/03

	Current Month	Year to Date	Budget to Date	Variance
INCOME				
Member Dues	\$0.00	\$27,125.00	\$28,000.00	(\$875.00)
Terminated Members	\$0.00	(\$125.00)	\$0.00	(\$125.00)
Admin Charge-New Members	\$0.00	\$475.00	\$1,000.00	(\$525.00)
Fines	\$0.00	\$17,093.75	\$15,000.00	\$2,093.75
Raffle	\$0.00	\$986.00	\$1,000.00	(\$14.00)
Interest	\$11.41	\$145.69	\$500.00	(\$354.31)
Roger Rockas	\$0.00	\$2,663.50	\$0.00	\$2,663.50
Retreat	\$0.00	\$3,901.00	\$3,800.00	\$101.00
Races	\$0.00	\$1,957.00	\$0.00	\$1,957.00
Tailgate	\$0.00	\$520.00	\$720.00	(\$200.00)
Offsite Lunches	\$0.00	\$1,212.00	\$1,500.00	(\$288.00)
Christmas Party	\$0.00	\$2,525.00	\$3,000.00	(\$475.00)
Gift Exchange/Toys for Tots	\$0.00	\$121.00	\$0.00	\$121.00
Auction	(\$50.00)	\$4,525.00	\$0.00	\$4,525.00
Miscellaneous Income	\$0.00	\$1,934.57	\$500.00	\$1,434.57
Total Income	(\$38.59)	\$65,059.51	\$55,020.00	\$10,039.51
EXPENDITURE				
R.I. Dues	\$0.00	\$5,616.75	\$5,800.00	\$183.25
District Dues	\$0.00	\$5,242.94	\$5,800.00	\$557.06
Supplies and Postage	\$0.00	\$1,705.70	\$1,500.00	(\$205.70)
Computer Expenses and Web Site	\$0.00	\$522.00	\$300.00	(\$222.00)
Officer Expense	\$0.00	\$3,997.01	\$2,650.00	(\$1,347.01)
Terminated Members	\$0.00	\$250.00	\$1,800.00	\$1,550.00
Miscellaneous Expense	\$0.00	\$1,628.78	\$1,000.00	(\$628.78)
Bank Charges	\$5.40	\$13.12	\$0.00	(\$13.12)
Dist Conf and Assembly	\$0.00	\$0.00	\$250.00	\$250.00
Lunch-Tornino's	\$0.00	\$1,263.00	\$1,750.00	\$487.00
FGR Foundation	\$10,000.00	\$10,000.00	\$0.00	(\$10,000.00)
Programs	\$0.00	\$200.00	\$500.00	\$300.00
Speakers	\$0.00	\$0.00	\$1,500.00	\$1,500.00
Demotion Party	\$0.00	\$512.52	\$0.00	(\$512.52)
Bulletin	\$0.00	\$0.00	\$1,000.00	\$1,000.00
Banners, Badges, Pins	\$0.00	\$563.82	\$750.00	\$186.18
Hospitality and Fellowship	\$1,790.13	\$3,705.87	\$3,750.00	\$44.13
Blue Book	\$1,821.52	\$1,821.52	\$750.00	(\$1,071.52)
Rotary Information	\$0.00	\$62.47	\$250.00	\$187.53
Membership	\$0.00	\$0.00	\$500.00	\$500.00
Roger Rockas	\$0.00	\$2,550.00	\$0.00	(\$2,550.00)
Retreat	\$0.00	\$5,974.68	\$5,300.00	(\$674.68)
The Races	\$0.00	\$1,934.34	\$0.00	(\$1,934.34)
Mystery Dinner	\$0.00	\$34.62	\$0.00	(\$34.62)
Field Trips	\$579.98	\$1,373.01	\$0.00	(\$1,373.01)
Tailgate	\$0.00	\$82.11	\$860.00	\$777.89
Offsite Lunches	\$0.00	\$748.04	\$1,800.00	\$1,051.96
Christmas Party	\$0.00	\$3,242.81	\$4,000.00	\$757.19
Valentines Day	\$0.00	\$93.43	\$0.00	(\$93.43)
Auction	\$0.00	\$854.79	\$600.00	(\$254.79)
Camp Royal	\$0.00	(\$58.38)	\$0.00	\$58.38
Christmas Food Basket	\$0.00	\$2,000.00	\$0.00	(\$2,000.00)
Community Projects	\$0.00	\$0.00	\$1,250.00	\$1,250.00
Bullard Interact	\$0.00	\$0.00	\$250.00	\$250.00
SJM Interact	\$0.00	\$0.00	\$250.00	\$250.00

Rotary Club of Fig Garden

Club Accounts

Income & Expenditure: Comparison to Budget to April 03

Printed 5/16/03

	Current Month	Year to Date	Budget to Date	Variance
Youth Exchange	\$0.00	\$0.00	\$250.00	\$250.00
Paul Harris	\$450.00	\$450.00	\$500.00	\$50.00
Group Study Exchange	\$0.00	\$0.00	\$500.00	\$500.00
Total Expenditure	\$14,647.03	\$56,384.95	\$45,410.00	(\$10,974.95)
Excess (Deficit)	(\$14,685.62)	\$8,674.56	\$9,610.00	\$21,014.46

FIG GARDEN ROTARY CLUB

FOUNDATION
BOARD OF DIRECTORS

*Regular Meeting - 21 May 2003:

*Members Present:

*Directors:

Daniel Bonyhadi
Jamie Franklin
August Hioco
Matt Merzoian
Howard Reed
Steve Rontell
Richard Saroyan
David Stepp

*President:

Eric Fogderude

*Treasurer:

Scott Bristol

*Foundation Treasurer:

Ron Fletcher

*Past President:

John Skewes

*President-Elect:

Rod Coburn

*Secretary:

Doug Cords

**Special Guest: **

Paul Sahota, UBS
Paine Webber

*Others Present:

Steve Wilson
Jay Roll
Mike Gerardi
Tony Carr

The meeting was called to concurrent order by President Eric Fogderude with the Regular Board Meeting of the Fig Garden Rotary Club in the Boardroom of the Stoughton Davidson Accountancy Corporation at 2530 West Shaw Lane, Suite 101, Fresno, California at 7:03 a.m.

*TREASURER'S REPORT: (Ron Fletcher)

Ron furnished the Board with Income and Expense items for April, with Income totaling \$24,928 and Expenses totaling \$15,077. Income items emanated from Auction, Wheelchair Project, Paul Harris Foundation and a generous contribution from Daniel and Lorna Bonyhadi through the Foundation For Seniors. Major expenses were for Polio Plus and Community Service.

Accounts:

*Unrestricted Funds: \$122,961.
*Permanent Funds: 141,251.
*Totals: \$264,212.

Paul Sahota from UBS Paine Webber reviewed funding sources, as three individual brokerage accounts were combined for the current program. He works regularly with the 7-member Investment Committee, per our pre-set guidelines. Paul reviewed the Investment Holdings and changes in recent months. Returns average 2.81% since the program commenced.

President Eric lauded Past Foundation Treasurer Tripp Pound for his extraordinary past service on Investments. Paul shared with the Board his appreciation for the quality work performed by the Investment Committee.

It was MSC to approve the Treasurer's Report as presented.

*ADJOURNMENT: Concurrent With The Regular Board Meeting, Adjourned At 8:30 a.m. by President Eric Fogderude.

*NEXT MEETING: 16 July 2003 at Stoughton Davidson Accountancy Corporation

RESPECTFULLY SUBMITTED BY DOUG CORDS, Ph.D., FOUNDATION SECRETARY.

FIG GARDEN ROTARY FOUNDATION
STATEMENT OF REVENUE, EXPENSES AND CASH BALANCES
APRIL 30, 2003

	TOTAL FYE	BUDGET	MONTH	MONTH	MONTH	MONTH	MONTH	MONTH	MONTH	MONTH	MONTH	MONTH	MONTH	MONTH	MONTH	MONTH	MONTH	TOTAL FYE
	6/30/02	6/30/03	7/31/02	8/31/02	9/30/02	10/31/02	11/30/02	12/31/02	1/31/03	2/28/03	3/31/03	4/30/03	5/31/03	6/30/03	6/30/03	6/30/03	6/30/03	6/30/03
REVENUE:																		
AUCTION- 2003	\$0	\$60,000										43330	22643					\$65,973
AUCTION- 2002	67,908					472												\$472
AUCTION- 2001	4,120																	0
5TH AVE FUNDRAISER	0	10,000																36,242
DONATIONS	12,702			400	3,800	2,125	220	345	17,505	18,737	1,105	2,286						18,116
CLEAR CHNL COM - JAZZ/COO	6,000	10,000	11,094	2,500					3,600	4,235								13,594
EARNINGS - FOUNDATION	1,810	1,500	111	98	98	4	4	3	5	7	8	10						349
EARNINGS - PERM. FUND	2,463	10,000	80	75	150													305
CONTRIB - FGR	18,000	0																0
CONTRIB - PERM. FUND	0	5,000	(5,433)	935	(5,430)	(2,980)	3,248	416	(1,420)	(1,060)	(128)	4,525						10,000
UNREAL GAIN-PERM. FUND	(24,484)																	(7,327)
	88,519	96,500	5,852	4,008	(1,381)	(379)	3,472	764	19,690	21,919	985	16,821	0	0				137,724
EXPENSES:																		
ADMINISTRATIVE	16	100		25														\$25
AUCTION - 2003	1,000	15,000			450	317	80				16,725	927						17,652
AUCTION - 2002	18,669										480							1,327
AUCTION - 2001	2,096																	0
5TH AVE FUNDRAISER	0																	10,989
DONATIONS	7,305						250				511							250
AVENUES OF SERVICE:																		0
COMMUNITY SERVICE	53,725	50,000			6,693	1,350	3,014		3,500	14,000	17,693	5,200						51,450
VOCATIONAL SERVICE	0	5,000																0
INTERNATIONAL SERVICE	0	5,000			560					18,000	0							18,560
VOCATIONAL SCHOLARSHIP	5,000	0																0
R.J. - POLIO PLUS	0	10,000																8,950
CONTRIB - PERM. FUND	0	5,000										8,950						0
	87,811	90,100	0	25	7,703	1,667	0	3,344	3,525	42,453	35,409	15,077	0	0				109,203
EXCESS OF REVENUES	708	\$6,400	\$5,852	\$3,983	(\$9,084)	(\$2,046)	\$3,472	(\$2,560)	\$16,165	(\$20,534)	(\$34,424)	\$1,744	\$0	\$0				28,521
OVER EXPENSES																		
BEG. CASH BALANCE	234,983																	235,691
ENDING CASH BALANCE	\$235,691																	\$264,212
RESTRICTED AMOUNTS																		
Paul Harris				1,100														
				\$1,100														
EXPENDITURES ENCUMBERED																		
** REMAINING UNDESIGNATED																		
COMM SER FOR 2001-02									2000									
									\$2,000									
WASHINGTON MUTUAL CHECKING	\$7,108																	\$47,358
DWR - LIQUID ASSET ACCT	89,928																	75,603
PERMANENT FUND	138,655																	141,251
	\$235,691																	\$264,212
TOTAL																		
WASHINGTON MUTUAL CHECKING																		\$47,358
FOUNDATION RESERVE ACCOUNT																		75,603
PERMANENT FUND (ENDOWMENT)																		141,251
TOTAL																		\$264,212
DEPOSITS																		
SEE PG.2																		
OTHER ENCUMBERED FUNDS																		
INTERNATIONAL SERVICE																		
EXCHANGE STUDENTS-\$2600																		

OTHER ENCUMBERED FUNDS
INTERNATIONAL SERVICE
EXCHANGE STUDENTS-\$2600

Fig Garden Rotary Foundation

April 2003

* Summary of Deposits:

Checking Interest — \$10⁰⁰
Wheel chair Project — 450⁰⁰
Paul Harris Donations — 915⁰⁰
Auction 2003 — 22,643⁵²
Foundation for Seniors (Alzheimers) — 920⁵²

Total \$24,928⁵²

* Summary of Expenses:

The Rotary Foundation (Paul Harris) — \$ 8,950⁰⁰
Crime Stoppers — 12,000⁰⁰
Marjorie Mason Center — 2,500⁰⁰
Leukemia & Lymphoma Society — 1,500⁰⁰
Auction 2003 — 927⁰⁰

Total \$15,077

UBS PAINWEBBER INC.
 FIG GARDEN FINANCIAL CENTER
 5200 NO. PALM, SUITE 101
 FRESNO, CA 93704-7669
 PZ1A004538-X6 - 0403 - FE - 0

Your Financial Advisor
 SAHOTA, GURKIRPAL (PAUL)
 559-226-2800/800-423-8797

**UBS PaineWebber InsightOneSM
 Business Services Account BSA[®]**

PZ1A004538-X6

Account Number: FE 31031 20

April 2003

his month at a glance

Value on March 31	\$	126,773.45
Value on April 30	\$	141,251.50
Money fund and other sweep option balance in 04/30 value	\$	26,307.64

arnings summary

arnings are for the current calendar year. All prior year entries are summarized separately. This information should not be used for tax purposes. Refer to the disclosure on the back of the first page.

	Current period	Year-to-date
S PaineWebber Money fund dividends	\$ 10.62	\$ 46.63
Interest	.00	137.26
Total current year security earnings	\$ 236.60	\$ 236.60
or year(s) entries and adjustments	\$ 247.22	\$ 420.49
Total security earnings	\$ 247.22	\$ 424.95

Asset summary

Asset summary is to the disclosure on the back of the first page for information on assets excluded from this summary.

	% of portfolio	Value
Money funds/sweep options	36.53	51,592.77
Actual funds	18.62	26,307.64
Invested assets	44.85	63,351.09
Value on April 30	100.00	\$ 141,251.50
		\$ 141,251.50

Handwritten notes:
 + 247.22
 + 137.26
 = 384.48
 + 126,773.45
 = 141,251.50
 Net Page 1 of 4



Bulletin Board

UBS PAINWEBBER WILL SOON HAVE A NEW BRAND NAME - UBS - AND A NEW BROKER DEALER NAME - UBS FINANCIAL SERVICES INC. RESOURCELINE 1-800-BSA-0140; ACCOUNT #: 095031031 VISIT OUR WEB SITE AT WWW.UBSPAINWEBBER.COM.

Investment objectives

The following return objective and risk profile describe overall goals for this account. For each account held, you choose one return objective and primary and, if applicable, secondary risk profile. A full description of the alternatives is included on the back of the first page. If you have questions regarding these objectives or wish to change them, please contact your Financial Advisor or Branch Manager at your branch office to update your account objectives.

Return objective: Current income & capital appreciation
Risk profile: Primary: Moderate
 Secondary: Conservative

Account Number: FE 31031 20
 Your Financial Advisor
 SAHOTA, GURKIRPAL (PAUL)
 559-226-2800/800-423-8797

**UBS PaineWebber InsightOneSM
 Business Services Account BSA[®]**

Statement Period: April 2003

PZ1A004539-X6

Activity highlights

	Current period	Year-to-date
Deposits	\$ 10,000.00	\$ 10,000.00
Program fees and related services	(311.64)	(619.85)
Change from activity listed above	\$ 9,688.36	\$ 9,380.15

Portfolio summary

	Current period	Year-to-date
Opening value	\$ 126,773.45	\$ 129,584.08
Change from Activity Highlights	9,688.36	9,380.15
Net security earnings	247.22	424.95
Change in value of investments	(4,542.47)	1,882.32
Value on April 30	\$ 141,251.50	\$ 141,251.50

Asset portfolio

In available, prices, income and current values may be approximate and thus gains/losses may not be accurately reflected. Refer to the disclosure on the back of the first page. \$ indicates recommendation and price target under review. UBS Warburg is currently unable to display recommendation data on this company. For further information, please contact your Financial Advisor. An asterisk (*) indicates a change in the original transaction data from the prior month or the display of new data input at your branch office. Gains/losses are not calculated for zero coupon investments.

Certificates of deposit

Upon CDs

Quantity	Face value	Description	Value	Est. annual income	Trade date	Face value purchased	Purchase price	Cost basis
13,000	13,000	CD INDEPENDENT BK EAST RATE 02.00% MATURES 10/23/03 INTEREST EARNED FROM 10/23/02 1ST INTEREST PAYMENT 10/23/03	12,972.05	260	10/31/02	13,000	99,799	12,973
12,000	12,000	CD DISCOVER BANK RATE 02.500% MATURES 11/08/04 INTEREST EARNED FROM 11/08/02 1ST INTEREST PAYMENT 05/08/03	12,098.64	300	10/31/02	12,000	100,000	12,000

Fig Garden Rotary Endowment Account

Asset Allocation

US Large Co. Equity	\$ 24,388.96	17.27%
US Med/Sm Co. Equity	\$ 24,386.85	17.26%
Balanced	\$ -	%
Int'l Equity	\$ 14,575.28	10.32%
Int'l Fixed Income	\$ -	0.00%
US Fixed Income	\$ 51,592.77	36.53%
Cash / M.M	\$ 26,307.64	18.62%
	\$ 141,251.50	100.00%

Account Allocation

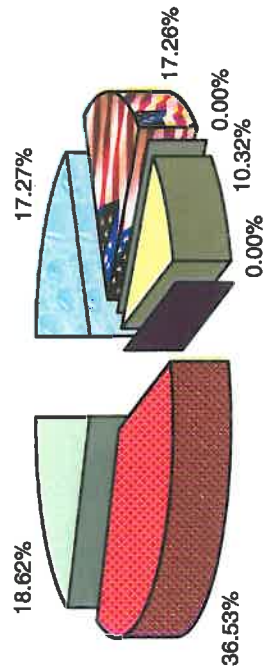

<input type="checkbox"/> US Large Co. Equity	<input checked="" type="checkbox"/> US Med/Sm Co. Equity
<input type="checkbox"/> Balanced	<input type="checkbox"/> Int'l Equity
<input type="checkbox"/> Int'l Fixed Income	<input checked="" type="checkbox"/> US Fixed Income
<input type="checkbox"/> Cash / M.M	

Investment Holdings

as of 4/30/03	Cost Basis	Value Jan 01, 2003	Value 4/30/2003	% Chg from 1/1/2003
<u>US Large Co. Equity:</u>				
Income Fund of America	\$ 11,107.99	\$ 10,417.91	\$ 11,778.48	13.06%
Pimco Value Fund	\$ 11,979.65	\$ 11,195.52	\$ 12,610.48	12.64%
<u>US Med/Sm Co. Equity:</u>				
Liberty Acorn Fund	\$ 11,094.31	\$ 10,415.86	\$ 12,117.60	16.34%
Pimco Small Cap Value	\$ 11,990.29	\$ 11,087.68	\$ 12,269.25	11.16%
<u>Balanced:</u>				
<u>Int'l Equity</u>				
Templeton Foreign	\$ 14,730.49	\$ 13,777.98	\$ 14,575.28	5.79%
<u>US & Int'l Fixed Income:</u>				
CD Independent Bank 2% due 10/23/03	\$ 12,973.87	\$ 12,916.93	\$ 12,972.05	0.43%
CD Discover Bank 2.5% due 11/08/04	\$ 12,000.00	\$ 12,043.08	\$ 12,098.64	0.46%
CD Key Bank & Trust 3.1% due 11/08/05	\$ 13,000.00	\$ 13,123.76	\$ 13,221.65	0.75%
CD Pan American Bank 3.65% due 10/30/06	\$ 12,930.84	\$ 13,185.38	\$ 13,300.43	0.87%
<u>Cash / Money Market:</u>				
Money Market	\$ 16,372.06	\$ 21,449.98	\$ 26,307.64	
TOTAL PORTFOLIO	\$ 128,179.50	\$ 129,564.08	\$ 141,251.50	9.02%
Foundation Account Value				\$ 75,603.19



Paul Sahota - Financial Advisor

FIG GARDEN ROTARY CLUB

BOARD OF DIRECTORS

*Regular Meeting: 16 July 2003:

*Members Present:

*Directors:

August Hioco
Matt Merzoian
Jeff Oliver
Steve Rontell

*Past-President:

Eric Fogderude

*Others Present:

Ron Fletcher
Doug Brinkley

*Foundation Treasurer:

Jeff Garza

*President:

Rod Coburn

*Secretary:

Doug Cords

*President-Elect:

Jamie Franklin

The meeting was called to order by President Dr. Rod Coburn at 7:05 a.m. in the Boardroom of the Stoughton Davidson Accountancy Corporation at 2530 West Shaw Lane, Suite 101, Fresno, California 93711.

*CONSENT ITEMS:

*Attendance For Month Of May, 2003	=	80%
*Attendance For Month Of June, 2003	=	80%
*Minutes Of Board Meeting Of 21 May 2003		
*Minutes Of Board Meeting Of 13 June 2003		
*Membership As Of 30 June 2003	=	102

It was MSC to approve the Consent Items as presented.

*TREASURER'S REPORT:

No report this month. Year Budget to be presented next month by Treasurer Scott Bristol.

*SECRETARY'S REPORT:

(Doug Cords)

District Attendance Figures for the months of April and May were circulated. Our Club is consistently a top performer in District attendance.

Dr. Coburn was asked to follow Past President Fogderude's pleas last year at Area-Wide Presidents' Meetings to implore local clubs to send in our members' make-ups. Three Clubs consistently do so, with the others being either sporadic or non-responsive.

Joyce Constant and Dan Rowley have been terminated as members, for Attendance-related Problems which could not be abated, despite good efforts.

*SECRETARY, Continued:

Recent Fresno Bee publicity on "Thumbs Up" (for Blood Center) and on "Unfolding Hearts" was circulated, as well as a District Newsletter blurb on our Club's "Mystery Dinner."

Special thanks to Treasurer Scott Bristol for his immediate help in June when RI called the Secretary threatening to pull the Club's Charter immediately for non-payment of dues. Scott dropped his accounting work, retrieved the documents and provided them for the Secretary to show RI it was in error and our fees were indeed paid timely.

The "Semi Annual Worksheet" was recently completed by leaders and the sum of \$3,014.85, for six months' dues, is being remitted to RI.

Demographic Information for "Planning Guide" was completed. Our last Classification Survey was completed three years ago and it is time to update the document, for use in membership development.

It was MSC to be dark on the following days:

- *28 November
- *26 December
- * 2 January

Secretary to notify Judy Perkins at TorNino's.

Discussion ensued regarding COG Tony Carr, an experienced former member. Tony continually has missed his COG Duties and has been non-responsive to the Secretary's pleas for fulfilling his assignments or asking for another COG to step in. August Hioco will work with Tony in the weeks upcoming, to help. Tony has manifold responsibilities in opening the Heart Hospital, which are taken into account, however, improvement must be displayed.

The Secretary will tabulate the January-June Attendance Figures shortly and will publish in AVENUES. Following time for corrections, the Year's Total 100% Attendance Awards will be published and awards given at a Friday meeting. It appears that, during President Eric's year, Fig Garden Rotarians earned 100% attendance at a record rate.

COG Dennis Archer unfortunately used the Club's e-mail list as a tool for soliciting business. Secretary informed Dennis of the need to abate this promotion, as the list is for Official Rotary Business only, and asked for a verifying note from him to that effect. No reply has been forthcoming.

Holly Johnson wrote to the Club a lovely note of appreciation for her Community Service Award and Scholarship. It was requested that our members on the Selection Committee ask the Interact Advisors to make certain that thank-you letters are written by recipients as a courtesy. Discussion ensued regarding the possibility of issuing checks with a system to make sure that the monies indeed pay for school-related costs.

Fig Garden Rotary is now displaying the two-year-old RI trend in decline of membership. Each member was asked to try to sponsor a quality new COG this year, and get behind Craig Deshields' leadership in Membership Development and Retention.

*SECRETARY, Continued:

Darryl Booth was inducted into Membership on 30 May; he is Director August Hioco's son-in-law and has already displayed strong leadership.

Ted Fleener, sponsored by John Heberger and Mary Lou Gunn, will be published in AVENUES this week.

It was MSC to approve the nomination to membership of Past District Governor Roy Massey. Sponsors are Rod Coburn and Eric Fogderude. Due to the lateness of the proposal vis-a-vis this meeting, the Board granted an indulgence to the Secretary to concurrently work with Classification and Membership, with a report next month.

*PRESIDENT-ELECT'S REPORT: (Jamie Franklin)

The Wheelchair Project, with units to be distributed in Quito, Ecuador, is on target for an October delivery. There is an issue with regard to the local Rotary Club's paying for a Customs Duty, a step which the Wheelchair Foundation deems essential as a participatory gesture. Howard Reed shall handle travel and delivery logistics.

*PAST PRESIDENT'S REPORT: (Eric Fogderude)

Eric welcomed cordially his successor, Dr. Coburn, and again extended his thanks to the Board for contributions made during his year. Eric is now taking an inventory of computer equipment and will shortly report his findings to the Board.

*PRESIDENT'S TIME: (Dr. Rod Coburn)

Richard Saroyan will be leading our Centennial Project, restoration of the Theater at Bullard High School.

Jeff Garza and Jamie Franklin are to be new signators on the Washington Mutual account. Eric Fogderude and Ron Fletcher are to be removed from the signature card. It was MSC to approve these changes.

The Board was polled as to what information should be sent in the monthly "Board Packet." Since financials are distributed personally at each meeting, they will not be sent (via fax or mail) again.

It was MSC to approve funding up to \$100. for our Club's participation in the PRLS (Potential Rotary Leaders Seminar).

At the 8 August meeting, Jean Irwin will be keynote speaker; we will be hosting seven other local Clubs in a Joint Meeting Format. It was MSC to pay up to \$300. for our Club's portion of the speaker's costs and a donation to the Foundation which supports her program. A discussion of logistics regarding both Visiting Rotarian sign-ins and efficient ways to handle payments for lunch ensued. The Secretary will set up separate sign-up sheets for each Rotary Club we are hosting, and President Rod will confer with TorNino's Judy Perkins regarding payment station(s).

*PRESIDENT'S TIME, Continued:

There will be a "Special Interest Seminar" on 16 August.

Art Farkas is spearheading a committee to update/revise our Website and Electronic Bulletin formats.

Craig DeShields is spearheading Membership and will be developing a revised Fig Garden Rotary brochure for prospective members.

Per Howard Reed's input recently, the Board discussed changing the Weekly Raffle Prizes into a "contest format," as follows:

*1/4 of the weekly proceeds distributed to Raffle winner

*1/4 of the weekly proceeds distributed to Raffle second place, if he/she can pull a "Joker" from a deck of cards - this 1/4 is to be carried over from week to week until won

*a third, "tangible" prize will be available for winners' choices as well

President Rod will fine-tune this program with Howard, prior to its implementation. The sense of the Board is to approve the changes.

It was the sense of the Board to forego a contribution in honor of the life of the deceased wife of RI President Jonathan Mayajabye, preferring instead to keep our funds locally focused. Secretary will send a card of condolence from our Club.

President Rod shared his vision for Speaker's Gifts for his year. Books from Petunias's Place will be purchased, and the weekly Speaker will be given a FGR pen to take home, and asked to sign the book. It will then be donated to one of our sponsored elementary schools. The plan is for a member to go to the school, read the book to a class, and then present it for the library.

It was MSC to ask the President to select "Senior" members of our Club to act in the productive capacity as Mentor for each new COG.

A Rotary International credit card program will be promoted at an upcoming meeting.

*AVENUES OF SERVICE:

*CLUB SERVICE: (August Hioco)

The Avenue Of Service has programs for each month of our Rotary year. Duck Races will occur in August, the Retreat and a COG Meeting are scheduled for September and a Day At The Races happens in October.

The Board expressed its enthusiasm for a strong year of activities, many of which are focused on our families' participation.

*COMMUNITY SERVICE:

(Steve Rontell and Jeff Oliver)

Steve and Jeff presented the Committee's recommendations for our support in this initial month of our Rotary year, as follows:

It was MSC to approve the sum of \$1,000. for sponsorship of 40 campers through the Sequoia Council of the Boy Scouts Of America; each camper must provide/raise one-half of his/her support costs.

It was MSC to approve the amount of \$1,060. for a backup power device and security computer firewall purchase for Criminal Justice Alternatives, Inc. Past President Eric has experience through the courts with this organization and strongly supported the funding.

It was MSC to provide the amount of \$1,222. for supplies and membership fees for Fresno Survivors Of Suicide Loss, Inc., with strong feelings again about the great worth of this program.

It was MSC to provide \$550. for the Salvation Army's "Back To School Backpack Program, through the Susan B. Anthony School; this will provide 250 packs and supplies.

The Directors noted their excitement at the response to Steve's call for more participation from members and the diligence with which each funding proposal receives in the evaluation process.

*VOCATIONAL SERVICE:

(Matt Merzoian)

No report this month.

*INTERNATIONAL SERVICE:

No report this month.

*OLD BUSINESS:

Steve Rontell noted that Greg Baxter shortly will provide the Board with an update on the status of our Club's loan to Playland/Storyland.

*NEW BUSINESS:

No new business this month.

*ADJOURNMENT: President Rod adjourned the meeting at 8:44 a.m.

*NEXT MEETING: 20 August 2003

Respectfully Submitted By Doug Cords, Ph.D., Club Secretary.

FIG GARDEN ROTARY CLUB

FOUNDATION
BOARD OF DIRECTORS

*Regular Meeting: 16 July 2003:

*Members Present:

*Directors:

August Hioco
Matt Merzoian
Jeff Oliver
Steve Rontell

*Past-President:

Eric Fogderude

*Others Present:

Ron Fletcher
Doug Brinkley

*Foundation Treasurer:

Jeff Garza

*President:

Rod Coburn

*Secretary:

Doug Cords

*President-Elect:

Jamie Franklin

The meeting was called to concurrent order with the Regular Board Meeting of the Fig Garden Rotary Club by President Dr. Rod Coburn in the Boardroom of the Stoughton Davidson Accountancy Corporation at 2530 West Shaw Lane, Suite 101, Fresno, California at 7:05 a.m.

*TREASURER'S REPORT: (Jeff Garza)

Past Foundation Treasurer Ron Fletcher reviewed Income and Expense Items for May, 2003; June figures were not available and will be presented by Jeff Garza next month.

Great appreciation was again accorded to Mary Lou Gunn and Clear Channel Communications for continued, significant financial contributions.

Past President Eric Fogderude leaves the Investment Committee, with President Rod Coburn taking the seat. There will be a meeting August 5.

A review of the Foundation's association with Washington Mutual will be forthcoming, including the Visa Machine policy for our Auction.

*Accounts:

*Unrestricted Funds:	\$117,857.
*Permanent Funds:	<u>147,113.</u>
*Totals:	\$264,970.

It was MSC to approve the Treasurer's Report as presented.

*ADJOURNMENT: Concurrent With Regular Meeting, Adjourned At 8:44 a.m. by President Rod Coburn.

*NEXT MEETING: 20 August 2003

Respectfully Submitted By Doug Cords, Ph.D., Foundation Secretary.

Fig Garden Rotary Foundation

May 2003

* Summary of Deposits:

Checking Interest	_____	8 ⁰⁰
Wheel chair Project	_____	150 ⁰⁰
Paul Harris Donations	_____	520 ⁰⁰
Total		<u>\$ 678⁰⁰</u>

* Summary of Expenses:

The Rotary Foundation (Paul Harris)	_____	400
San Joaquin Memorial High School Scholarship	_____	2,000
Bullard High School Scholarship	_____	2,000
Auction 2003	_____	425
Auction 2004	_____	1,000
Total		<u>\$ 5,825⁰⁰</u>

Fig Garden Rotary Endowment Account

Asset Allocation

US Large Co. Equity	\$ 30,401.02	20.67%
US Med/Sm Co. Equity	\$ 30,277.62	20.58%
Balanced	\$ -	%
Int'l Equity	\$ 17,493.20	11.89%
Int'l Fixed Income	\$ -	0.00%
US Fixed Income	\$ 51,895.23	35.28%
Cash / M.M	\$ 17,046.41	11.59%
	\$ 147,113.48	100.00%

Account Allocation

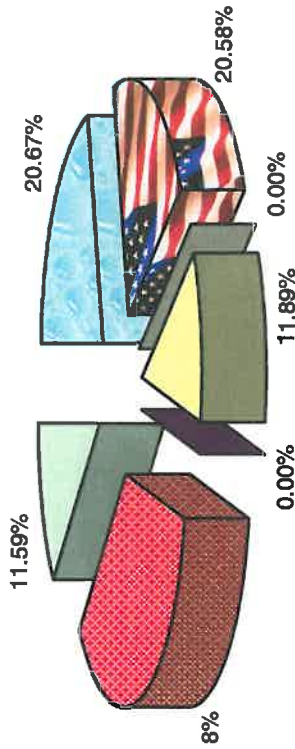

<input type="checkbox"/> US Large Co. Equity	<input checked="" type="checkbox"/> US Med/Sm Co. Equity
<input type="checkbox"/> Balanced	<input type="checkbox"/> Int'l Equity
<input checked="" type="checkbox"/> Int'l Fixed Income	<input checked="" type="checkbox"/> US Fixed Income
<input type="checkbox"/> Cash / M.M	



Investment Holdings

as of 5/30/03

	Cost Basis	Value 5/30/2003	Percent Gain / loss
<u>US Large Co. Equity:</u>			
Income Fund of America	\$ 13,098.55	\$ 14,322.00	9.34%
Pimco Value Fund	\$ 13,978.64	\$ 16,079.02	15.03%
<u>US Med/Sm Co. Equity:</u>			
Liberty Acorn Fund	\$ 13,079.23	\$ 15,033.78	14.94%
Pimco Small Cap Value	\$ 13,976.53	\$ 15,243.84	9.07%
<u>Balanced:</u>			
<u>Int'l Equity</u>			
Templeton Foreign	\$ 16,729.41	\$ 17,493.20	4.57%
<u>US & Int'l Fixed Income:</u>			
CD Independent Bank 2% due 10/23/03	\$ 12,973.87	\$ 12,989.47	0.12%
CD Discover Bank 2.5% due 11/08/04	\$ 12,000.00	\$ 12,127.32	1.06%
CD Key Bank & Trust 3.1% due 11/08/05	\$ 13,000.00	\$ 13,291.85	2.25%
CD Pan American Bank 3.65% due 10/30/06	\$ 12,930.84	\$ 13,486.59	4.30%
<u>Cash / Money Market:</u>			
Money Market	\$ 17,046.41	\$ 17,046.41	0.00%
TOTAL PORTFOLIO	\$ 138,813.48	\$ 147,113.48	
Cash & Cash Equivalents	\$ 17,064.41	\$ 17,046.41	
Total Securities	\$ 121,767.07	\$ 130,067.07	6.82%

Foundation Account Value \$ 75,646.60

This is not an official Statement.
Strictly for illustrative purposes only.

Paul Sahota
Financial Advisor

UBS PAINWEBBER INC.
 FIG GARDEN FINANCIAL CENTER
 5200 NO. PALM, SUITE 101
 FRESNO, CA 93704-7669

Your Financial Advisor
 SAHOTA, GURKIRPAL (PAUL)

UBS PaineWebber InsightOneSM
 Business Services Account BSA[®]

May 2003

This month at a glance

Value on April 30	\$	141,251.50
Value on May 30	\$	147,113.48
Money fund and other sweep option balance in 05/30 value	\$	17,046.41

Earnings summary

Earnings are for the current calendar year. All prior year entries are summarized separately. This information should not be used for tax purposes. Refer to the disclosure on the back of the first page.

	Current period	Year-to-date
JBS PaineWebber Money fund dividends	\$ 14.37	\$ 61.00
Other dividends	.00	137.26
Interest	348.61	585.21
Total current year security earnings	\$ 362.98	\$ 783.47
Prior year(s) entries and adjustments	2.00	4.46
Net security earnings	\$ 362.98	\$ 787.93

Asset summary

Refer to the disclosure on the back of the first page for information on assets excluded from this summary.

	% of portfolio	Value
Certificates of deposit	35.28	51,895.23
Money funds/sweep options	11.59	17,046.41
Mutual funds	53.13	78,171.84
Net invested assets	100.00	\$ 147,113.48
Value on May 30		\$ 147,113.48

Handwritten notes:
 Money Fund 362.98
 + 516.23
 = 879.21
 879.21 + 17,046.41 = 179,255.62
 Total change in Net Assets
 179,255.62 - 141,251.50 = 38,004.12
 (38,004.12) (38,004.12)
 141,251.50 + 38,004.12 = 179,255.62

FIG GARDEN ROTARY FOUNDATION
 ENDOWMENT FUND
 5180 N PALM AVE SUITE 101
 FRESNO CA 93704-2230



Bulletin Board

AS OF JUNE 9, UBS PAINWEBBER WILL HAVE A NEW BRAND NAME - UBS - AND A NEW BROKER/DEALER NAME - UBS FINANCIAL SERVICES INC.

VISIT OUR WEB SITE AT WWW.UBSPAINWEBBER.COM.

Investment objectives

The following return objective and risk profile describe overall goals for this account. For each account held, you choose one return objective and primary and, if applicable, secondary risk profile. A full description of the alternatives is included on the back of the first page. If you have questions regarding these objectives or wish to change them, please contact your Financial Advisor or Branch Manager at your branch office to update your account objectives.

Return objective: Current income & capital appreciation

Risk profile: Primary: Moderate

Secondary: Conservative

Statement Period: May 2003

Your Financial Advisor
SAHOTA, GURKIRPAL (PAUL)

Activity highlights

	Current period	Year-to-date
Deposits	410.42	10,410.42
Withdrawals	-75.00	-75.00
Program fees and related services	.00	-619.85
Net change from activity listed above	335.42	9,715.57

Handwritten note: Funds with the Barings (Special Interest Fee)

Portfolio summary

	Current period	Year-to-date
Opening value	\$ 141,251.50	\$ 129,564.08
Net change from Activity Highlights	335.42	9,715.57
Net security earnings	362.98	787.93
Change in value of investments	5,163.58	7,045.90
Value on May 30	\$ 147,113.48	\$ 147,113.48

Asset portfolio

When available, prices, income and current values may be approximately and thus gains/losses may not be accurately reflected. Refer to the disclosure on the back of the first page. § indicates recommendation and price target under review. ± indicates recommendation and price target information temporarily suspended pending review. UBS Warburg is currently unable to display recommendation data on this company. For further information, please contact your Financial Advisor. An asterisk (*) indicates a change in the original transaction data from the prior month or the display of new data input at your branch office. Gains/losses are not calculated for zero coupon investments. *Pending adjustment* or *PIA* indicates cost basis has not yet been allocated as a result of a spin-off or taxable exchange.

Certificates of deposit

Coupon CDs

Total face value	maturity	Description	Value	Est. annual income	Trade date	Face value purchased	Purchase price	Cost basis
13,000		CD INDEPENDENT BK EAST	12,989.47	260	10/31/02	13,000	99.799	12,973
		RATE 02.000% MATURES 10/23/03						
		INTEREST EARNED FROM 10/23/02						
		1ST INTEREST PAYMENT 10/23/03						
12,000		CD DISCOVER BANK	12,127.32	300	10/31/02	12,000	100.000	12,000
		RATE 02.500% MATURES 11/08/04						
13,000		CD KEY BANK AND TRUST	13,291.85	403	10/31/02	13,000	100.000	13,000
		RATE 03.100% MATURES 11/08/05						
13,000		CD PAN AMERN BK FSB	13,486.59	475	10/31/02	13,000	99.468	12,930
		RATE 03.650% MATURES 10/30/06						



UBS PAINWEBBER INC.
 FIG GARDEN FINANCIAL CENTER
 5200 NO. PALM, SUITE 101
 FRESNO, CA 93704-7669

Your Financial Advisor
 SAHOTA, GURKIRPAL (PAUL)

UBS PaineWebberSM
 Business Services Account BSA[®]

May 2003

This month at a glance

Value on April 30	\$	75,603.19
Value on May 30	\$	75,646.60
Money fund and other sweep option balance in 05/30 value	\$	75,646.60

Activity highlights

	Current period	Year-to-date
Money fund checks paid	\$.00	\$ -15,000.00
Net change from activity listed above	\$.00	\$ -15,000.00

Portfolio summary

	Current period	Year-to-date
Opening value	\$ 75,603.19	\$ 90,373.45
Net change from Activity Highlights	.00	-15,000.00
Net security earnings	43.41	273.15
Value on May 30	\$ 75,646.60	\$ 75,646.60

Earnings summary

Earnings are for the current calendar year. All prior year entries are summarized separately. This information should not be used for tax purposes. Refer to the disclosure on the back of the first page.

	Current period	Year-to-date
BS PaineWebber Money fund dividends	\$ 43.41	\$ 254.35
for year(s) entries and adjustments	.00	18.80
Net security earnings	\$ 43.41	\$ 273.15

⊕ 43.41

FIG GARDEN ROTARY FOUNDATION
 5180 N PALM AVE SUITE 101
 FRESNO CA 93704-2230



Bulletin Board

AS OF JUNE 9, UBS PAINWEBBER WILL HAVE A NEW BRAND NAME - UBS - AND A NEW BROKER/DEALER NAME - UBS FINANCIAL SERVICES INC.

VISIT OUR WEB SITE AT WWW.UBSPAINWEBBER.COM.

Asset summary

Refer to the disclosure on the back of the first page for information on assets excluded from this summary.

	% of portfolio	Value
Money funds/sweep options	100.00	75,646.60
Value on May 30	\$	75,646.60

507E03170004600000430 303150AF01 CPGFO081A
FIG GARDEN ROTARY FOUNDATION
ENDOWMENT FUND
ATTN: R.M. POUND III
7576 N. INGRAM #102
FRESNO CA 93711-5823

Your Broker/Dealer is
CITIGROUP GLOBAL MKTS INC.
 Your Financial Consultant
 STIRLING/BROWN
 5250 NO. PALM AVE.
 SUITE 321
 FRESNO CA 93704
 559-431-5900
 Branch: 800-640-4465



Citigroup Global Markets Inc., member NYSE, NASD, and other principal exchanges. Smith Barney is a division and service mark of Citigroup Global Markets Inc. and its affiliates and is used and registered throughout the world. CITIGROUP and the Umbrella Device are trademarks and service marks of Citicorp or its affiliates and are used and registered throughout the world. Citigroup Global Markets Inc. is a member of the Securities Investor Protection Corporation (SIPC).

Account value	Last period	This period
Cash balance	\$ 410.42	\$ 0.00
Net value	\$ 410.42	\$ 0.00

Cash balance	This period
Opening balance	\$ 410.42
Securities bought and other subtractions	-75.00
Securities sold and other additions	0.00
Deposits	75.00
Withdrawals	-410.42
Closing balance	\$ 0.00

A free credit balance in any securities account may be paid to you on demand. Although properly accounted for on our books and records, these funds may be used for our business purposes.

This was a reversal of their fees & credited to the account

*Then,
Paul Sekt - transferred
This to Paine webel*

See Paine webel

FIG GARDEN ROTARY CLUB

BOARD OF DIRECTORS

*Regular Meeting: 20 August 2003 --

*Members Present:

*Directors:

August Hioco
Matt Merzoian
Jeff Oliver
Howard Reed
Dave Stepp
Steve Wilson

*Past President:

Eric Fogderude

*Foundation Treasurer:

Jeff Garza

*Secretary:

Doug Cords

*Others Present:

Past President Marty Dietz
Past President John Heberger

*President:

Rod Coburn

*President-Elect:

Jamie Franklin

The meeting was called to order by President Dr. Rod Coburn at 7:03 a.m. in the Boardroom of the Stoughton Davidson Accountancy Corporation at 2530 West Shaw Lane, Suite 101, Fresno, California 93711.

*CONSENT ITEMS:

*Attendance For The Month Of July, 2003	=	83%
*Membership As Of 1 August 2003	=	101
*Minutes Of Board Meeting Of 16 July 2003		

It was MSC to approve the Consent Items as presented.

*TREASURER'S REPORT:

Treasurer Scott Bristol is recovering from back surgery, but still went the extra mile to have ready both a Budget and Accounts from July for Board presentation.

It was MSC to approve the 2003-2004 Proposed Budget. It was also MSC to approve the Balance Sheet and Income and Expenditures ending 31 July 2003.

Extensive discussion ensued with regard to members with accounts in arrears. Past President Eric Fogderude shared his activity during the previous year, including several polite collection letters. At next month's meeting, a proposed Board Policy on arrears will be presented, and individuals with long overdue accounts will be addressed.

*SECRETARY'S REPORT:

(Doug Cords)

AVENUES recently published, per Board Requirement, the final six months' attendance figures for each member, in President Eric's year. The publication has been notified of all members' records which show a full year's 100% Attendance; publication should occur shortly. After a period allowed for corrections, President Rod will have a ceremony at a Friday meeting, to present the Awards.

Candi Maur of Unfolding Hearts wrote the Club a thoughtful thank-you letter for the recent contribution to its program.

Per Treasurer Scott Bristol's request, it was MSC to approve the following signators for the CITI Bank Account:

*Scott Bristol
*Rod Coburn
*Jamie Franklin
*Doug Cords

The resolution will be delivered to Scott, to take to the bank for records.

A recent FRESNO BEE article focused upon the World Health Organization's efforts to wipe out Polio, with no coverage afforded to Rotary International's part in the program. The Secretary, out of concern, contacted the RI Public Relations Office in Evanston and received a return fax which noted the unfortunate situation that news outlets edit out information, to suite their requirements for publication space. It was suggested by Vivian Flore at RI Headquarters that a Letter To The Editor, noting Rotary's involvement and that of our local Club, be written. The Secretary indeed wrote that letter to the Fresno Bee's editorial page Editor.

The June, 2003 District Attendance figures were circulated. Again, Fig Garden Rotary Club substantially leads other clubs in average attendance.

Bruce Rolph has attained the age of 60 and 25 years of service. It was MSC to approve him for the "85-Rule," which negates attendance requirements and reduces dues to one-half. Treasurer Scott Bristol to be notified, for billing change.

Although he wrote resigning membership, long-time member Jack Tacchino was terminated prior due to failure to make either the 30% Home Club or the 60% Overall Attendance requirements. The Secretary noted a dismal track record of having members come back after an "Excuse From Attendance Requirements" as a truly productive Rotarian. Some have, but most have not.

Jay Roll has experienced a change of employment status. In a letter, he asked for "inactive status." Since none is available, his resignation was accepted by the Board, with deep regret. It was the sense of the Board to offer to Jay a return to membership within six months, with a waiver of all start-up fees.

Ted Fleener, General Manager of Fresno Mitsubishi, was recently inducted; his sponsors were John Heberger and Mary Lou Gunn.

*SECRETARY'S REPORT, Continued:

The blood donations from Lorna and Daniel Bonyhadi over the past year have rescued the memberships of 10 Fig Garden Rotarians. Names were circulated, with the hope that those on the list could be encouraged individually by Board Members to earn better attendance records.

-New Member Proposals:

GENE MOLENKAMP

Employer: Peter Jacobsen Productions - Save Mart Shootout
Current Member Of The Redmond (Seattle) Rotary Club
Sponsors Are Rod Coburn and Doug Cords; Rotarian John Townsend brought Gene to visit the club.

Membership Committee has approved.
Proposed Classification: Entertainment - Event Management

It was MSC to approve the nomination.

KAREN McMILLAN

Self Employed: McMillan Consulting
Long-Time Volunteer For Fig Garden Rotary Club Events
Sponsors Are Carole Reed and Daniel Bonyhadi

Membership Committee has approved.
Proposed Classification: Computers - Professional Network Services

It was MSC to approve the nomination.

Secretary to immediately forward to Rotary Information for next induction step.

Last month, the Board approved the nomination of Roy Massey for membership. During the 7-Day Notice Period, an Objection in writing was filed. Our Club's By-Laws are clear in steps to follow regarding this step. In this particular instance, Membership Committee was notified of the Objection and is handling the required research steps.

The Secretary reviewed for the Board the specific steps required and President Rod read from the By-Laws. Marty Dietz, Membership Chair, reviewed the status to date. Past President Allen Taylor has been asked to help with the process. Past President John Heberger and President Rod noted the necessity of going over each step with By-Laws "guru" Bob Bergin. John also recommended that By-Laws be amended to clarify the exact contacts (President and/or Secretary) for 7-Day Notice Filings. Past President Eric Fogderude shared some well-received ideas regarding the integrity of this process. The Membership Chair will notify the Board when he is ready to present.

*PRESIDENT-ELECT'S REPORT: (Jamie Franklin)

Jamie updated the Board on the Quito, Ecuador site for the Wheelchair Project. The chairs are now being manufactured, with anticipated date of completion on/about 10 September. After that, two weeks are required for Independent Customs Inspection and a shipping cycle of 45-60 days.

*PRESIDENT-ELECT'S REPORT, Continued:

The tentative distribution timeframe is the first week of December.

Next year's Auction, at the Casablanca, will be 27 March 2004.

*PAST-PRESIDENT'S REPORT (Eric Fogderude)

Eric has received reports from three of the four members involved with computer equipment. Once the final member has reported, Eric will present to the Board an inventory and recommendations for handling our computer-related assets.

*PRESIDENT'S TIME: (Rod Coburn)

Rod is developing a current Board Roster and asked for corrections to the spreadsheet he has developed.

Rod attended the Potential Rotary Leaders Seminar recently. He invited the Bullard High School Rotaract President, and was very impressed with his abilities. Potential Rotarians can be developed through the venue.

Rod thanked Tom Ogden, August Hioco and Craig DeShields for attending the Foundation Seminar on 16 August. August was also a major presenter.

Rod confirmed kind thank-you letters from Past-President Eric Fogderude to Chuck Poochigian and his wife Debbie and George Radanovich for their roles in providing flags (flown over the respective capitols) for Rotary Playland/Storyland. Doug and Wendy Cords obtained and provided the flags for Fig Garden Rotary Club.

*AVENUES OF SERVICE:

*Club Service: (August Hioco and Steve Wilson)

The Great Duck Race Event will occur this Friday, 22 August, at the Cords' residence. Discussion followed regarding possible billing of participants. Because of no notice to this end and a history that this is a Club-funded event, no billings shall be forthcoming. Steve Wilson is sending out e-mail reminders, due to a rather low sign-up.

There will be a COG recognition event in September. In October, the Day At The Races will occur and the FSU Tailgate is 15 November.

August reviewed with the Board current requirements for COG members, to update documents. Coincidentally, President Rod was doing the same review. The Board agreed on the language and it will be distributed.

*Community Service: (Jeff Oliver)

It was MSC to approve the sum of \$700. for the Assistance League's "Operation School Bell," a program supported by the Club in the past.

It was MSC to approve the sum of \$3,000. for our continued participation in elementary schools "Perfect Attendance" Program, with the purchase of bicycles. Bill Robinson is spearheading the project again this year.

*Club Service, continued:

The "Centennial Project," refurbishing the Theater at Bullard High School, is headed by Richard Saroyan, Project Manager. Rotarian General Ed Munger is graciously volunteering as a consultant, sharing his sound system abilities. The Assessment/Need Stage is currently underway, to determine the scope of the Project.

*Vocational Service: (Dave Stepp and Matt Merzoian)

The Job Shadowing Project's plans are underway, with the event to take place this year, in Late October.

This year, the Scholarship Program will also include the Presidents and Officers of the Interact Clubs at the Bullard and San Joaquin Memorial campuses. These leaders will be asked to work with campus sponsors, to enhance the selection and delivery processes.

*International Service: (Howard Reed)

Our Exchange Student will arrive tomorrow at noon at the air terminal, (8/21). Her name is Marie Miyasaki and she is from Nagamo, Japan. Joetta Winter will be her first host. We need a third host family to volunteer.

Howard noted that "Friendship Teams" will be set up for the year, to transport Marie to activities and meetings and for our individual families to include her with events.

Marie will be introduced to the members at our meeting Friday 22 August.

*OLD BUSINESS:

No Old Business this meeting.

*NEW BUSINESS:

The sum of \$500., previously approved, will be allocated to David Bonnar for Website Host Costs; David will be the Club's "Webmaster."

Dr. Coburn encouraged Board members to review websites of other Clubs.

It was MSC to approve no more than \$2,000. for the purchase of hardware and software to update the antiquated, ~~unreliable~~-system the Club owns for the Secretary's use. (Editorial Note: the Secretary may be the one who is both old and unreliable...)

*ADJOURNMENT: President Rod adjourned the meeting at 8:54 a.m.

*NEXT MEETING: 17 September 2003.

Respectfully Submitted By Doug Cords, Ph.D., Club Secretary.

Rotary Club of Fig Garden

Club Accounts Annual Budgets

FISCAL YEAR END 03-04

Printed 8/12/03
Total

INCOME

Member Dues	\$28,000.00
Terminated Members	\$0.00
Prior Year	\$0.00
Admin Charge-New Members	\$1,200.00
Special Projects	\$0.00
Fines	\$20,000.00
Raffle	\$1,200.00
Interest	\$600.00
Demotion Party	\$5,000.00
Roger Rockas	\$0.00
Retreat	\$3,800.00
Races	\$0.00
Mystery Dinner	\$0.00
Field Trips	\$0.00
Tailgate	\$720.00
Offsite Lunches	\$1,800.00
Christmas Party	\$3,000.00
Foundation Dinner	\$0.00
Gift Exchange/Toys for Tots	\$0.00
Auction	\$0.00
River Rafting	\$0.00
Miss California	\$0.00
Miscellaneous Income	\$600.00
Community Projects	\$0.00
Wheelchair Project	\$0.00
Scholarships	\$0.00
Paul Harris	\$0.00
President's Changeover	\$0.00
Income Total	\$65,920.00

Rotary Club of Fig Garden

Club Accounts Annual Budgets

FISCAL YEAR END 03-04

Printed 8/12/03

Total

EXPENSE

R.I. Dues	\$5,800.00
District Dues	\$5,800.00
Supplies and Postage	\$1,800.00
Computer Expenses and Web Site	\$360.00
Officer Expense	\$4,000.00
Insurance	\$0.00
Terminated Members	\$1,600.00
Miscellaneous Expense	\$1,800.00
Bank Charges	\$180.00
Dist Conf and Assembly	\$500.00
Lunch-Tornino's	\$1,800.00
Nominating Comm Dinner	\$0.00
FGR Foundation	\$5,000.00
Unallocated	\$0.00
Programs	\$600.00
Speakers	\$900.00
Demotion Party	\$5,000.00
Bulletin	\$300.00
Banners, Badges, Pins	\$600.00
Hospitality and Fellowship	\$3,900.00
Blue Book	\$900.00
Rotary Information	\$300.00
Membership	\$600.00
Roger Rockas	\$0.00
Storyland Under the Stars	\$0.00
Retreat	\$6,000.00
The Races	\$0.00
Mystery Dinner	\$0.00
Field Trips	\$1,200.00
Tailgate	\$800.00
Offsite Lunches	\$1,800.00
Christmas Party	\$3,500.00
Foundation Dinner	\$0.00
Valentines Day	\$120.00
Auction	\$900.00
River Rafting	\$0.00
Camp Royal	\$900.00
Christmas Food Basket	\$2,000.00
Blood Drive	\$0.00
Community Projects	\$1,500.00
Fresno City College Scholarships	\$0.00
Bullard Scholarships	\$0.00
SJM Scholarships	\$0.00
Miss California Scholarships	\$0.00
Other Scholarships	\$0.00
Bullard Interact	\$300.00
SJM Interact	\$300.00
Fresno Pacific Rotaract	\$0.00
Bank Fees	\$0.00
Youth Exchange	\$300.00
Paul Harris	\$1,500.00
International Project	\$0.00
Group Study Exchange	\$500.00
Expense Total	\$63,360.00
Excess (Deficit)	\$2,560.00

Rotary Club of Fig Garden

Club Accounts

Balance sheet for period ending 31 July 03

Printed 8/12/03

ACCUMULATED FUNDS

Club Funds

Balance at beginning of year	\$55,806.20
Excess (Deficit) for period	\$11,764.13
Balance to Date	\$67,570.33

TOTAL FUNDS

\$67,570.33

Represented by:

ASSETS

Checking Account-Cal Fed	\$2,997.80
Morgan Stanley Dean Witter	\$26,666.59
Member's Current Accounts	\$34,955.94
Note Rec - Playland	\$5,000.00
Total Assets	\$69,620.33

LIABILITIES

Foundation Payable	\$500.00
PHF Clearing	\$50.00
Woodward Park Bench Project	\$1,500.00
Total Liabilities	\$2,050.00

NET ASSETS

\$67,570.33

Rotary Club of Fig Garden

Club Accounts

Income & Expenditure: Current Month & Year to Date to July 03

Printed 8/12/03

	Current Month	Year to Date
INCOME		
Member Dues	\$11,625.00	\$11,625.00
Demotion Party	\$150.00	\$150.00
Miscellaneous Income	\$74.13	\$74.13
Total Income	\$11,849.13	\$11,849.13
EXPENDITURE		
Demotion Party	\$75.00	\$75.00
Offsite Lunches	\$10.00	\$10.00
Total Expenditure	\$85.00	\$85.00
Excess (Deficit)	\$11,764.13	\$11,764.13

Rotary Club of Fig Garden

Club Accounts

Income & Expenditure: Current Year vs Previous Year to July 03

Printed 8/12/03

	Month		Year to Date	
	Current Year	Previous Year	Current Year	Previous Year
INCOME				
Member Dues	\$11,625.00	\$13,500.00	\$11,625.00	\$13,500.00
Raffle	\$0.00	\$186.00	\$0.00	\$186.00
Demotion Party	\$150.00	\$0.00	\$150.00	\$0.00
Roger Rockas	\$0.00	\$76.00	\$0.00	\$76.00
Miscellaneous Income	\$74.13	\$235.00	\$74.13	\$235.00
Total Income	\$11,849.13	\$13,997.00	\$11,849.13	\$13,997.00
EXPENDITURE				
R.I. Dues	\$0.00	\$3,133.75	\$0.00	\$3,133.75
Computer Expenses and Web Site	\$0.00	\$522.00	\$0.00	\$522.00
Miscellaneous Expense	\$0.00	\$527.50	\$0.00	\$527.50
Demotion Party	\$75.00	\$0.00	\$75.00	\$0.00
Hospitality and Fellowship	\$0.00	(\$200.00)	\$0.00	(\$200.00)
Mystery Dinner	\$0.00	\$34.62	\$0.00	\$34.62
Offsite Lunches	\$10.00	\$0.00	\$10.00	\$0.00
Camp Royal	\$0.00	(\$58.38)	\$0.00	(\$58.38)
Total Expenditure	\$85.00	\$3,959.49	\$85.00	\$3,959.49
Excess (Deficit)	\$11,764.13	\$10,037.51	\$11,764.13	\$10,037.51

Rotary Club of Fig Garden

Club Accounts

Income & Expenditure: Comparison to Budget to July 03

Printed 8/12/03

	Current Month	Year to Date	Budget to Date	Variance
INCOME				
Member Dues	\$11,625.00	\$11,625.00	\$14,000.00	(\$2,375.00)
Admin Charge-New Members	\$0.00	\$0.00	\$100.00	(\$100.00)
Raffle	\$0.00	\$0.00	\$100.00	(\$100.00)
Interest	\$0.00	\$0.00	\$50.00	(\$50.00)
Demotion Party	\$150.00	\$150.00	\$0.00	\$150.00
Offsite Lunches	\$0.00	\$0.00	\$150.00	(\$150.00)
Miscellaneous Income	\$74.13	\$74.13	\$50.00	\$24.13
Total Income	\$11,849.13	\$11,849.13	\$14,450.00	(\$2,600.87)
EXPENDITURE				
R.I. Dues	\$0.00	\$0.00	\$2,900.00	\$2,900.00
Supplies and Postage	\$0.00	\$0.00	\$150.00	\$150.00
Computer Expenses and Web Site	\$0.00	\$0.00	\$30.00	\$30.00
Officer Expense	\$0.00	\$0.00	\$100.00	\$100.00
Miscellaneous Expense	\$0.00	\$0.00	\$150.00	\$150.00
Bank Charges	\$0.00	\$0.00	\$15.00	\$15.00
Lunch-Tornino's	\$0.00	\$0.00	\$150.00	\$150.00
Programs	\$0.00	\$0.00	\$50.00	\$50.00
Speakers	\$0.00	\$0.00	\$75.00	\$75.00
Demotion Party	\$75.00	\$75.00	\$0.00	(\$75.00)
Bulletin	\$0.00	\$0.00	\$25.00	\$25.00
Banners, Badges, Pins	\$0.00	\$0.00	\$50.00	\$50.00
Hospitality and Fellowship	\$0.00	\$0.00	\$325.00	\$325.00
Blue Book	\$0.00	\$0.00	\$75.00	\$75.00
Rotary Information	\$0.00	\$0.00	\$25.00	\$25.00
Membership	\$0.00	\$0.00	\$50.00	\$50.00
Field Trips	\$0.00	\$0.00	\$100.00	\$100.00
Offsite Lunches	\$10.00	\$10.00	\$0.00	(\$10.00)
Community Projects	\$0.00	\$0.00	\$125.00	\$125.00
Bullard Interact	\$0.00	\$0.00	\$25.00	\$25.00
SJM Interact	\$0.00	\$0.00	\$25.00	\$25.00
Youth Exchange	\$0.00	\$0.00	\$25.00	\$25.00
Paul Harris	\$0.00	\$0.00	\$125.00	\$125.00
Total Expenditure	\$85.00	\$85.00	\$4,595.00	\$4,510.00
Excess (Deficit)	\$11,764.13	\$11,764.13	\$9,855.00	(\$7,110.87)

FIG GARDEN ROTARY CLUB

FOUNDATION

BOARD OF DIRECTORS

*Regular Meeting: 20 August 2003 --

*Members Present:

*Directors:

August Hioco
Matt Merzoian
Jeff Oliver
Howard Reed
Dave Stepp
Steve Wilson

*Past President:

Eric Fogderude

*Foundtion Treasurer:

Jeff Garza

*Secretary:

Doug Cords

*Others Present:

Past President Marty Dietz
Past President John Heberger

*President:

Rod Coburn

*President-Elect:

Jamie Franklin

The meeting was called to concurrent order with the Regular Board Meeting of the Fig Garden Rotary Club by President Rod Coburn in the Boardroom of the Stoughton Davidson Accountancy Corporation at 2530 West Shaw Lane, Suite 101, Fresno, California at 7:03 a.m.

*TREASURER'S REPORT: (Jeff Garza)

Jeff presented to the Board the figures ending June 30, 2003, as compiled by Past Treasurer Ron Fletcher. He then reviewed reports ending 31 July, with the Balance Sheet showing net worth of \$266,824. Income items were reviewed and four Community Service Projects, previously approved, were funded. Jeff also reviewed the UBS Account printout from Paul Sahota.

Jeff will develop a yearly budget, based on President Rod's notation of about \$72,000 in available funds for projects. The Investment Committee met on August 5; it will be investing more cash into equities, to reach a goal of 70% of the portfolio as invested. The next meeting will be 11 November.

*Accounts: (as of 30 June)

*Unrestricted Funds:	\$104,730.00
*Permanent Funds:	148,740.00
*Totals:	<u>\$253,470.00</u>

It was MSC to approve the Treasurer's Report, as presented.

The Washington Mutual checking account will be closed. Director Dave Stepp has graciously made it possible for the Foundation to enjoy an account with Union Bank at no cost, which will also afford a VISA Account.

It was MSC to approve new signators for this account, as follows:

*Jeff Garza
*Rod Coburn
*Jamie Franklin
*Doug Cords

Jeff provided signature cards for completion by the above-noted individuals.

*ADJOURNMENT: Concurrent With Regular Meeting, Adjourned By President Rod Coburn at 8:54 a.m.

*NEXT MEETING: 17 September 2003

Respectfully Submitted By Doug Cords, Ph.D., Foundation Secretary.

FIG GARDEN ROTARY FOUNDATION

Net Worth
(Includes unrealized gains)
As of 7/31/2003

8/18/2003

Page 1

<u>Account</u>	<u>7/31/2003 Balance</u>
ASSETS	
Cash and Bank Accounts	
UBS Savings-Cash	90,727.62
WM Checking	25,727.31
TOTAL Cash and Bank Accounts	<u>116,454.93</u>
Investments	
UBS Endowment	150,369.64
UBS Savings	0.00
TOTAL Investments	<u>150,369.64</u>
TOTAL ASSETS	<u>266,824.57</u>
LIABILITIES	0.00
OVERALL TOTAL	<u>266,824.57</u>

Income/Expense
7/1/2003 Through 7/31/2003

8/18/2003

Page 1

Category Description	7/1/2003- 7/31/2003	OVERALL TOTAL
INCOME		
Interest Inc	36.33	36.33
Paul Harris Receipts	520.00	520.00
TOTAL INCOME	<u>556.33</u>	<u>556.33</u>
EXPENSES		
Community Service Donations 2003-2004	3,832.00	3,832.00
TOTAL EXPENSES	<u>3,832.00</u>	<u>3,832.00</u>
OVERALL TOTAL	<u>-3,275.67</u>	<u>-3,275.67</u>

DONATIONS
 Itemized Categories
 7/1/2003 Through 7/31/2003

8/18/2003

Page 1

Cat/Sub	Date	Account	Num	Description	Memo	Cl	Amount
EXPENSES							
Community Service	<i>DONATIONS</i>						
	7/18/2...	WM Chec...	628	Fresno Survivors of Suicide	Board Mtg 7/16/03	R	-1,222.00
	7/18/2...	WM Chec...	629	Salvation Army	Board Mtg 7/16/03	R	-550.00
	7/18/2...	WM Chec...	630	Sequoia Council of Boy S...	Board Mtg 7/16/03	R	-1,000.00
	7/18/2...	WM Chec...	631	Criminal Justice Advocates	Board Mtg 7/16/03	R	-1,060.00
TOTAL Community S...							<u>-3,832.00</u>
TOTAL EXPENSES							<u>-3,832.00</u>
OVERALL TOTAL							<u>-3,832.00</u>

Fig Garden Rotary Endowment Account

Asset Allocation

US Large Co. Equity	\$ 31,448.99	20.86%
US Med/Sm Co. Equity	\$ 32,039.76	21.25%
Int'l Equity	\$ 18,664.80	12.38%
Int'l Fixed Income	\$ -	0.00%
US Fixed Income	\$ 51,716.36	34.30%
Cash / M.M	\$ 16,908.46	11.21%
	\$ 150,778.37	100.00%

Account Allocation

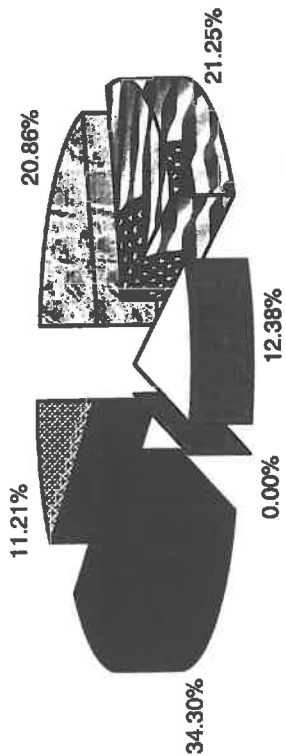

<input checked="" type="checkbox"/> US Large Co. Equity	<input checked="" type="checkbox"/> US Med/Sm Co. Equity
<input type="checkbox"/> Int'l Equity	<input type="checkbox"/> Int'l Fixed Income
<input checked="" type="checkbox"/> US Fixed Income	<input checked="" type="checkbox"/> Cash / M.M

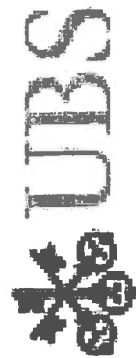

Investment Holdings

	Cost Basis	Value 7/31/2003	Percent Gain / loss
<u>US Large Co. Equity:</u>			
Income Fund of America	\$ 13,098.55	\$ 14,340.60	9.48%
Pimco Value Fund	\$ 13,978.64	\$ 17,108.39	22.39%
<u>US Med/Sm Co. Equity:</u>			
Liberty Acorn Fund	\$ 13,079.23	\$ 16,212.90	23.96%
Pimco Small Cap Value	\$ 13,976.53	\$ 15,826.86	13.24%
<u>Int'l Equity</u>			
Templeton Foreign	\$ 16,729.41	\$ 18,664.80	11.57%
<u>US & Int'l Fixed Income:</u>			
CD Independent Bank 2% due 10/23/03	\$ 12,973.87	\$ 12,992.20	0.14%
CD Discover Bank 2.5% due 11/08/04	\$ 12,000.00	\$ 12,135.00	1.13%
CD Key Bank & Trust 3.1% due 11/08/05	\$ 13,000.00	\$ 13,228.41	1.76%
CD Pan American Bank 3.65% due 10/30/06	\$ 12,930.84	\$ 13,360.75	3.32%
<u>Cash / Money Market:</u>			
Money Market	\$ 16,908.46	\$ 16,908.46	0.00%
TOTAL EQUITIES			
	\$ 121,707.17	\$ 133,869.91	9.91%
Cash & Cash Equivalents			
	\$ 16,908.46	\$ 16,908.46	
Foundation Account Value			
	\$	\$ 90,727.62	

This is not an official Statement.
Strictly for illustrative purposes only.

Paul Sahota
Financial Advisor

Fig Garden Rotary Foundation

June 2003

Summary of Deposits:

checking Interest	\$ 8
wheel chair Project	75
Paul Harris Donations	1,990
clear Channel Donations	8,000
Auction 2003	6,230
woodward Park Bench Project	3,836

Total \$ 20,139

Summary of Expenses:

The Rotary Foundation (Paul Harris)	\$ 2,000
The Rotary Foundation (Polio Plus)	10,000
Auction 2003	714
Auction 2004	Ø
Unfolding Hearts (Community Ser.)	3,800
Duncan Polytechnic (Vocational Scholarship)	1,000
Woodward Park Bench Project (Comm. Ser.)	795
Paine Webber - Rotary Foundation Account (Transfer only)	15,000

Total

\$ 33,309

Fig Garden Rotary Endowment Account

Asset Allocation

US Large Co. Equity	\$ 30,892.43	20.77%
US Med/Sm Co. Equity	\$ 30,843.78	20.74%
Balanced	\$ -	%
Int'l Equity	\$ 17,937.60	12.06%
Int'l Fixed Income	\$ -	0.00%
US Fixed Income	\$ 51,850.14	34.86%
Cash / M.M	\$ 17,216.09	11.57%
	\$ 148,740.04	100.00%

Account Allocation

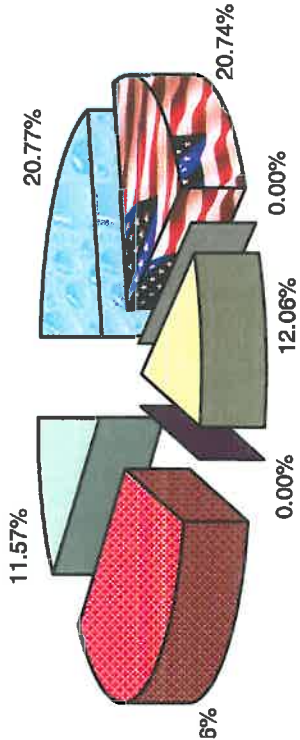

<input checked="" type="checkbox"/> US Large Co. Equity	<input checked="" type="checkbox"/> US Med/Sm Co. Equity
<input checked="" type="checkbox"/> Balanced	<input checked="" type="checkbox"/> Int'l Equity
<input checked="" type="checkbox"/> Int'l Fixed Income	<input checked="" type="checkbox"/> US Fixed Income
<input checked="" type="checkbox"/> Cash / M.M	



Investment Holdings

as of 6/30/03

	Cost Basis	Value 6/30/2003	Percent Gain / loss
<u>US Large Co. Equity:</u>			
Income Fund of America	\$ 13,098.55	\$ 14,331.30	9.41%
Pimco Value Fund	\$ 13,978.64	\$ 16,561.13	18.47%
<u>US Med/Sm Co. Equity:</u>			
Liberty Acorn Fund	\$ 13,079.23	\$ 15,493.29	18.46%
Pimco Small Cap Value	\$ 13,976.53	\$ 15,350.49	9.83%
<u>Balanced:</u>			
<u>Int'l Equity</u>			
Templeton Foreign	\$ 16,729.41	\$ 17,937.60	7.22%
<u>US & Int'l Fixed Income:</u>			
CD Independent Bank 2% due 10/23/03	\$ 12,973.87	\$ 12,989.47	0.12%
CD Discover Bank 2.5% due 11/08/04	\$ 12,000.00	\$ 12,152.04	1.27%
CD Key Bank & Trust 3.1% due 11/08/05	\$ 13,000.00	\$ 13,296.92	2.28%
CD Pan American Bank 3.65% due 10/30/06	\$ 12,930.84	\$ 13,411.71	3.72%
<u>Cash / Money Market:</u>			
Money Market	\$ 17,216.09	\$ 17,216.09	0.00%
TOTAL PORTFOLIO	\$ 138,983.16	\$ 148,740.04	
Cash & Cash Equivalents	\$ 17,216.09	\$ 17,216.09	
Total Securities	\$ 121,767.07	\$ 131,523.95	8.01%

Foundation Account Value \$ 75,691.29

This is not an official statement.
Strictly for illustrative purposes only.

Paul Sahota
Financial Advisor

B:

UBS Financial Services Inc.
FIG GARDEN FINANCIAL CENTER
5200 NO. PALM, SUITE 101
FRESNO, CA 93704-7669

Your Financial Advisor
SAHOTA, GURKIRPAL (PAUL)

UBS InsightOneSM Business Services Account BSA[®]

June 2003

This month at a glance

Value on May 30	\$	147,113.48
Value on June 30	\$	148,740.04
Money fund and other sweep option balance in 06/30 value	\$	17,216.09

Earnings summary

Earnings are for the current calendar year. All prior year entries are summarized separately. This information should not be used for tax purposes. Refer to the disclosure on the back of the first page.

	Current period	Year-to-date
UBS PaineWebber Money fund dividends	\$ 10.09	\$ 71.09
Other dividends	159.59	296.85
Interest	.00	585.21
Total current year security earnings	\$ 169.68	\$ 953.15
Prior year(s) entries and adjustments	.00	4.46
Net security earnings	\$ 169.68	\$ 957.61

Asset summary

Refer to the disclosure on the back of the first page for information on assets excluded from this summary.

	% of portfolio	Value
Certificates of deposit	34.86	51,850.14
Money funds/sweep options	11.57	17,216.09
Mutual funds	53.57	79,673.81
Net invested assets	100.00	148,740.04
Value on June 30	\$	148,740.04

Perm. Fund ⊕ 169.68
 ⊕ 1456.83
 ⊕ 16,265.6 — Perm Fund
 ⊕ 44.69 — Operating Fund
 ⊕ \$ 167.125 — Total Change of Both Funds
 Page 1 of 4

FIG GARDEN ROTARY FOUNDATION
ENDOWMENT FUND
5180 N PALM AVE SUITE 101
FRESNO CA 93704-2230



Bulletin Board
AS OF JUNE 9, WE HAVE A NEW
BRAND NAME - UBS - AND A NEW BROKER/DEALER
NAME - UBS FINANCIAL SERVICES INC.

VISIT OUR WEB SITE AT WWW.UBS.COM.

Investment objectives

The following return objective and risk profile(s) describe overall goals for this account. For each account held, you must provide one return objective, one primary risk profile and, if applicable, a secondary risk profile. A full description of the alternatives is included on the back of the first page. If you have questions regarding these objectives, disagree with or wish to change them, please notify your Financial Advisor or Branch Manager at your branch office. In writing or by telephone.

Return objective: Current income & capital appreciation

Risk profile: Primary: Moderate

Secondary: Conservative

UBS Financial Services Inc.
 FIG GARDEN FINANCIAL CENTER
 5200 NO. PALM, SUITE 101
 FRESNO, CA 93704-7669

Your Financial Advisor
 SAHOTA, GURKIRPAL (PAUL)

Business Services Account BSA®

June 2003

This month at a glance

value on May 30	\$	75,646.60
value on June 30	\$	75,691.29
Money fund and other sweep option balance in 06/30 value	\$	75,691.29

Activity highlights

	Current period	Year-to-date
Money fund checks paid	\$.00	\$ -15,000.00
Net change from activity listed above	\$.00	\$ -15,000.00

Portfolio summary

	Current period	Year-to-date
Opening value	\$ 75,646.60	\$ 90,373.45
Net change from Activity Highlights	.00	-15,000.00
Net security earnings	44.69	317.84
value on June 30	\$ 75,691.29	\$ 75,691.29

Earnings summary

Earnings are for the current calendar year. All prior year entries are summarized separately. This information should not be used for tax purposes. Refer to the disclosure on the back of the first page.

	Current period	Year-to-date
BS PaineWebber Money fund dividends	\$ 44.69	\$ 299.04
Other year(s) entries and adjustments	.00	18.80
Net security earnings	44.69	317.84

⊕ 44.69

FIG GARDEN ROTARY FOUNDATION
 5180 N PALM AVE SUITE 101
 FRESNO CA 93704-2230



Bulletin Board

AS OF JUNE 9, WE HAVE A NEW
 BRAND NAME - UBS - AND A NEW BROKER/DEALER
 NAME - UBS FINANCIAL SERVICES INC.

VISIT OUR WEB SITE AT WWW.UBS.COM.

Asset summary

Refer to the disclosure on the back of the first page for information on assets excluded from this summary.

	% of portfolio	Value
Money funds/sweep options	100.00	75,691.29
Value on June 30	\$	75,691.29

Fig Garden Rotary Foundation

June 2003

Summary of Deposits:

Checking Interest	\$ 8
wheel chair Project	75
Paul Harris Donations	1,990
clear channel Donations	8,000
Auction 2003	6,230
woodward Park Bench Project	3,836

Total \$ 20,139

Summary of Expenses:

The Rotary Foundation (Paul Harris)	\$ 2,000
The Rotary Foundation (Polio Plus)	10,000
Auction 2003	714
Auction 2004	0
Unfolding Hearts (community Ser.)	3,800
Duncan Polytechnic (Vocational Scholarship)	1,000
Woodward Park Bench Project (Comm. Ser.)	795
Paine Walker - Rotary Foundation Account (Transfer only)	15,000

Total \$ 33,309

Fig Garden Rotary Endowment Account

Asset Allocation

US Large Co. Equity	\$ 30,892.43	20.77%
US Med/Sm Co. Equity	\$ 30,843.78	20.74%
Balanced	\$ -	%
Int'l Equity	\$ 17,937.60	12.06%
Int'l Fixed Income	\$ -	0.00%
US Fixed Income	\$ 51,850.14	34.86%
Cash / M.M.	\$ 17,216.09	11.57%
	\$ 148,740.04	100.00%

Account Allocation

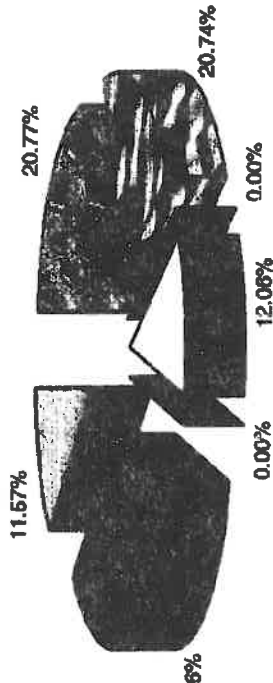

<input checked="" type="checkbox"/> US Large Co. Equity	<input checked="" type="checkbox"/> US Med/Sm Co. Equity
<input checked="" type="checkbox"/> Balanced	<input checked="" type="checkbox"/> Int'l Equity
<input checked="" type="checkbox"/> Int'l Fixed Income	<input checked="" type="checkbox"/> US Fixed Income
<input checked="" type="checkbox"/> Cash / M.M.	



Investment Holdings

as of 6/30/03

	Cost Basis	Value 6/30/2003	Percent Gain / loss
<u>US Large Co. Equity:</u>			
Income Fund of America	\$ 13,098.55	\$ 14,331.30	9.41%
Pimco Value Fund	\$ 13,978.64	\$ 16,561.13	18.47%
<u>US Med/Sm Co. Equity:</u>			
Liberty Acom Fund	\$ 13,079.23	\$ 15,493.29	18.46%
Pimco Small Cap Value	\$ 13,976.53	\$ 15,350.49	9.83%
<u>Balanced:</u>			
<u>Int'l Equity</u>			
Templeton Foreign	\$ 16,729.41	\$ 17,937.60	7.22%
<u>US & Int'l Fixed Income:</u>			
CD Independent Bank 2% due 10/23/03	\$ 12,973.87	\$ 12,989.47	0.12%
CD Discover Bank 2.5% due 11/08/04	\$ 12,000.00	\$ 12,152.04	1.27%
CD Key Bank & Trust 3.1% due 11/08/05	\$ 13,000.00	\$ 13,296.92	2.28%
CD Pan American Bank 3.65% due 10/30/06	\$ 12,930.84	\$ 13,411.71	3.72%
<u>Cash / Money Market:</u>			
Money Market	\$ 17,216.09	\$ 17,216.09	0.00%
Cash & Cash Equivalents		\$ 17,216.09	\$ 17,216.09

This is not an official Statement.
Strictly for illustrative purposes only.

Paul Sahota
Financial Advisor



UBS Financial Services Inc.
 FIG GARDEN FINANCIAL CENTER
 5200 NO. PALM, SUITE 101
 FRESNO, CA 93704-7869

Your Financial Advisor
 SAHOTA, GURKIRPAL (PAUL)

UBS InsightOneSM
Business Services Account BSA[®]

June 2003

his month at a glance

Value on May 30	\$ 147,113.48
Value on June 30	\$ 148,740.04
Money fund and other sweep option balance in 06/30 value	\$ 17,216.09

arnings summary

arnings are for the current calendar year. All prior year entries are summarized separately. This information should not be used for tax purposes. Refer to the disclosure on the back of the first page.

	Current period	Year-to-date
S. PaineWebber Money fund dividends	\$ 10.09	\$ 71.09
Interest	159.59	296.85
Total current year security earnings	.00	585.21
or year(s) entries and adjustments	\$ 169.68	\$ 953.15
Total security earnings	\$ 169.68	\$ 957.61

asset summary

Refer to the disclosure on the back of the first page for information on assets excluded from this summary.

	% of portfolio	Value
Certificates of deposit	34.86	51,850.14
Money funds/sweep options	11.57	17,216.09
Other mutual funds	53.57	79,673.81
Total invested assets	100.00	\$ 148,740.04
Value on June 30		\$ 148,740.04

Permi Fund @ 16.98
 @ 145.12
 @ 16,263.6 - Permi Fund
 @ 44.49 - operating fund
 Total Change of Both Funds
 @ \$ 16,712.5
 Page 1 of 4

FIG GARDEN ROTARY FOUNDATION
 ENDOWMENT FUND
 5180 N PALM AVE SUITE 101
 FRESNO CA 93704-2230



Bulletin Board
 AS OF JUNE 9, WE HAVE A NEW
 BRAND NAME - UBS - AND A NEW BROKER/DEALER
 NAME - UBS FINANCIAL SERVICES INC.

VISIT OUR WEB SITE AT WWW.UBS.COM

Investment objectives

The following return objective and risk profile(s) describe overall goals for this account. For each account held, you must provide one return objective, one primary risk profile and, if applicable, a secondary risk profile. A full description of the alternatives is included on the back of the first page. If you have questions regarding these objectives, disapprove with or wish to change them, please notify your Financial Advisor or Branch Manager at your branch office, in writing or by telephone.

Return objective: Current income & capital appreciation
Risk profile: Primary: Moderate
 Secondary: Conservative

UBS InsightOneSM
Business Services Account BSA[®]

Your Financial Advisor
SAHOTA, GURKIRPAL (PAUL)

Statement Period: June 2003

Activity highlights

	Current period	Year-to-date
Deposits	\$.00	\$ 10,410.42
Withdrawals	.00	-75.00
Plan fees and related services	.00	-619.85
Change from activity listed above	\$.00	\$ 9,715.57

Portfolio summary

	Current period	Year-to-date
Ending value	\$ 147,113.48	\$ 129,564.08
Change from Activity Highlights	.00	9,715.57
Security earnings	169.68	957.61
Change in value of investments	1,456.88	8,502.78
As of June 30	\$ 148,740.04	\$ 148,740.04

Investment portfolio

Available, prices, income and current values may be approximate and thus gains/losses may not be accurately reflected. An asterisk (*) indicates the calculation of unrealized gains/losses based upon a UBS Financial Services estimate to cost basis. The number "P" indicates cost basis information has been provided by a source other than UBS Financial Services. See the back of the first page for additional information. Gains/losses are not calculated on coupon investments. "Pending adjustment" or "P/A" indicates cost basis has not yet been allocated as a result of a spin-off or taxable exchange. § Indicates recommendation and price target under review. ‡ Indicates recommendation and price target information temporarily suspended pending review. UBS Securities LLC is currently unable to display recommendation data on this company. For further information, please contact your Financial Advisor.

Investment indicators of deposit

Investment CD's

Face value	Description	Value	Est. annual income	Trade date	Face Value purchased	Purchase price	Cost basis
13,000	CD INDEPENDENT BK EAST RATE 02.000% MATURES 10/23/03 INTEREST EARNED FROM 10/23/02	12,989.47	260	10/31/02	13,000	99.799	12,973
12,000	1ST INTEREST PAYMENT 10/23/03 CD DISCOVER BANK RATE 02.500% MATURES 11/08/04	12,152.04	300	10/31/02	12,000	100.000	12,000
13,000	CD KEY BANK AND TRUST RATE 03.100% MATURES 11/08/05	13,296.92	403	10/31/02	13,000	100.000	13,000
13,000	CD PAN AMERN BK FSB RATE 03.650% MATURES 10/30/06	13,411.71	475	10/31/02	13,000	99.468	12,930



UBS Financial Services Inc.
 FIG GARDEN FINANCIAL CENTER
 5200 NO. PALM, SUITE 101
 FRESNO, CA 93704-7669

Your Financial Advisor
 SAHOTA, GURKIRPAL (PAUL)

Business Services Account BSA®

TOTAL P.07

559 228 9298
 June 2003

Month at a glance

	Current period	Year-to-date
Balance on May 30	\$ 75,646.60	\$ 75,646.60
Balance on June 30	\$ 75,691.29	\$ 75,691.29
Money fund and other sweep option balance in 06/30 value	\$ 75,691.29	\$ 75,691.29

Activity highlights

	Current period	Year-to-date
Dividend checks paid	\$.00	\$ -15,000.00
Change from activity listed above	\$.00	\$ -15,000.00

Folio summary

	Current period	Year-to-date
Ending value	\$ 75,646.60	\$ 90,373.45
Change from Activity Highlights	.00	-15,000.00
Security earnings	44.69	317.84
Balance on June 30	\$ 75,691.29	\$ 75,691.29

Earnings summary
 All prior year entries are summarized separately. This information should not be used for purposes. Refer to the disclosure on the back of the first page.

	Current period	Year-to-date
PaineWebber Money fund dividends	\$ 44.69	\$ 299.04
Year(s) entries and adjustments	.00	18.80
Security earnings	\$ 44.69	\$ 317.84

⊕ 44.69

FIG GARDEN ROTARY FOUNDATION
 5180 N PALM AVE SUITE 101
 FRESNO CA 93706-2230



Bulletin Board
 AS OF JUNE 9, WE HAVE A NEW
 BRAND NAME - UBS - AND A NEW BROKER/DEALER
 NAME - UBS FINANCIAL SERVICES INC.

VISIT OUR WEB SITE AT WWW.UBS.COM.

Asset summary
 Refer to the disclosure on the back of the first page for information on assets excluded from this summary.

	% of portfolio	Value
Money funds/sweep options	100.00	\$ 75,691.29
Value on June 30		\$ 75,691.29

FIG GARDEN ROTARY CLUB

BOARD OF DIRECTORS

*SPECIAL MEETING - 4 SEPTEMBER 2003:

[Per Club By-Laws, This Special Meeting Was Duly-Noticed Via Electronic Mail And First-Class Mail Via President Rod Coburn]

*Members Present:

*Directors:

Mike Graves
Matt Merzoian
Jeff Oliver
Howard Reed
Steve Rontell
Steve Wilson

*President:

Rod Coburn

*Past President:

Eric Fogderude

*President-Elect:

Jamie Franklin

*Foundation Secretary:

Jeff Garza

*Secretary:

Doug Cords

*Others Present:

Past President John Heberger
Past President And Membership
Chairman Marty Dietz

The meeting was called to order at 5:30 p.m. by President Rod Coburn; Directors were guests in the Conference Room at the Edwin S. Darden Associates, Inc. offices at 6790 North West Avenue, Fresno, CA. 93711.

The sole focus of this specially-noticed and called meeting is to carefully discuss and evaluate the Objection, during the 7-Day Rule, of proposed member Roy Massey.

It was noted that the Club's By-Laws call for a closed/secret ballot if any Director so desires. President Rod Coburn so requested.

Past President and Membership Chairman Marty Dietz, per By-Laws presented findings of his study of the objections and related facts and circumstances. Marty covered all of the objections from member Daniel S. Bonyhadi derived from three e-mail communications and personal contact.

It is the recommendation of the Membership Committee to re-affirm Roy Massey as a proposed member of Fig Garden Rotary Club.

It was MSC to enter Executive Session to discuss a matter possibly subject to legal implications.

Past President John Heberger exited the conference room.

During this session, all efforts were made to cover, discuss and evaluate all salient information regarding the topic at hand.

Past President John Heberger returned to the meeting after it was MSC to leave Executive Session.

The closed vote took place, with ballots distributed by Secretary Doug Cords and collected by President-Elect Jamie Franklin. Each left the room and counted the ballots together.

The President-Elect and Secretary returned to the meeting to announce that there were not four "no" votes. The Board supports the Nomination of Roy Massey, following announced results per By-Laws.

President Coburn will notify Mr. Massey of the decision and share that two steps remain prior to his induction:

*remittance of initial check for fees payable

*resignation from The Rotary Club Of Fresno

As any member may so request, Mr. Bonyhadi has asked for a copy of the Minutes, which will be provided when approved at the next Board Meeting.

The Board is appreciative of the input given by Past President John Heberger who appropriately noted several essential protocol steps to close the issue. His experience with not-for-profit organizations was a valuable tool to ensure that the meeting was conducted appropriately and all due consideration given.

President Rod Coburn adjourned the meeting at 6:39 p.m.

Respectfully Submitted By Doug Cords, Ph.D., Secretary.

FIG GARDEN ROTARY CLUB

BOARD OF DIRECTORS

*Regular Meeting: 17 September 2003:

*Members Present:

*Directors:

Mike Graves
August Hioco
Matt Merzoian
Jeff Oliver
Howard Reed
Steve Rontell
David Stepp

*Foundation Treasurer:

Jeff Garza

*Treasurer:

Scott Bristol

*Secretary:

Doug Cords

*President:

Rod Coburn

*Other(s) Present:

*President-Elect:

Jamie Franklin

Paul Harris Chair Tom Ogden

The meeting was called to order by President Rod Coburn at 7:02 a.m. in the Boardroom of the Stoughton Davidson Accountancy Corporation at 2530 West Shaw Lane, Suite 101, Fresno, California 93711.

*CONSENT ITEMS:

*Minutes Of The 20 August 2003 Regular Board Meeting
*Minutes Of The 04 September 2003 Special Board Meeting
*Attendance For The Month Of August, 2003 = 82%
*Membership As Of 1 September 2003 = 101

It was MSC to approve the Consent Items as presented.

*TREASURER'S REPORT: (Scott Bristol)

(The Board happily welcomed back Scott after his recent shoulder surgery)

The Treasurer reviewed key accounts, as follows:

*Checking: \$10,534.
*Morgan Stanley: 26,666.
*Members' Accounts: 19,702.
*Playland Note: 5,000.

Scott will report in September the final accounting for the Annual Retreat.

We are a bit behind Budget to date - the Duck Races, due to its change of

*TREASURER'S REPORT, Continued:

the nature of the evening, which this year included a gorgeous catered supper, our Fig Garden Rotary Traveling Bar and rented tables and chairs for members and their guests.

It was MSC to approve the Treasurer's Report as presented.

*SECRETARY'S REPORT:

Due to a communications error last month on the part of the Secretary, one name was incorrectly approved and another omitted for the new Citibank account.

It was MSC to rescind the earlier Motion and substitute the following as signators:

Scott Bristol
Rod Coburn
Doug Cords
Eric Fogderude

Secretary to make a copy of these Board Minutes and forward promptly to Treasurer Scott Bristol, for processing.

Member Daniel Bonyhadi requested via e-mail to the President and the Secretary a copy of the Minutes for the "Executive Session" of the 4 September Fig Garden Rotary Club Special Board Meeting. The Minutes are not created separately for "Regular" and for "Special." The Board approved these Minutes during this meeting and a copy will be forwarded to Daniel, as requested, as these documents are for the Public Record.

Former member Jay Roll contacted the President regarding his situation. A misunderstanding may have created Jay's resignation. He had asked for an "Inactive Status" of membership, which is not available within the Club's By-Laws. Previously, the Board agreed to welcome Jay back at a future time with no up-front costs. His employment ended, resulting in his terminating. If/when Jay contacts the Secretary, he will be reinstated and returned to Membership.

Past District Governor Roy Massey will be inducted shortly into Fig Garden Rotary Club.

The 100% attendance Awards packages are ready for members to be recognized and President Rod shall schedule a special ceremony at a Friday meeting upcoming.

The following COGs need to attend a Board Meeting:

Joetta Winter
Darryl Booth

Jim Rodgers
Ted Fleener

Dennis Archer

*SECRETARY, Continued:

It was MSC to approve funding for the purchase of a moderately-priced scanner for the Avenues Editor. Joe Wettstead is to make the purchase and will be promptly be reimbursed by Treasurer Scott Bristol, upon presentation of the receipt.

The Secretary voiced a huge "thank you" to the Club Service Directors, August Hioco and Steve Wilson, for the professional way each developed the "Great Duck Races" at the Cords home. A special thank-you note and flowers were presented to Wendy Cords.

Pipeline:

GENE MOLLENKAMP, sponsored by Dr. Coburn and Dr. Cords, has asked to table his nomination until his Save Mart Great Golf Shootout Promotion has been completed. Bob Bergin will contact in October.

KAREN McMILLAN, sponsored by Carole Reed and Daniel Bonyhadi, will be inducted to Fig Garden Rotary this coming Friday, 19 September. The Secretary to have all items ready for presentation.

Past President ROBIN BALDIN will be returning to the Club, the result of a sincere and thoughtful re-recruiting effort by President Dr. Rod Coburn. Per previous Board action, fees are waived and Robin is under the "85-Rule." He requested no fanfare upon his return and the Board is deeply grateful to our President for his leadership in recovering a member lost.

There are no new Membership Proposals in hand at this time.

*PRESIDENT-ELECT'S REPORT: (Jamie Franklin)

The Wheelchair Foundation notified Jamie that the chairs are completed and ready for shipment. Shortly there will be an estimate of a delivery date to Ecuador.

The Annual Auction is 27 March 2004. Jamie has reviewed the historical documents and met with Dr. Coburn for further counsel. He has identified three critical "task areas," and announced the following leaders:

*External Marketing	=	David Bonnar
*Finance And Operations	=	Doug Brinkley
*Merchandise	=	To Be Announced

*PAST-PRESIDENT'S REPORT:

No Report This Month.

*PRESIDENT'S TIME: (Rod Coburn)

Rod noted the huge amount of time office staff is investing in Fig Garden Rotary Club official business at his practice, with the same individual investment of much time by the Secretary. Per previous

*PRESIDENT'S TIME, Continued:

extensive Board discussions, our Club perhaps is at the size wherein paid staff should be considered, as volunteers get "burned out" doing duties----Rotary Club Of Fresno, North Fresno Rotary Club and East Fresno Rotary Club all have paid individuals, the latter two using Members as staff, as a control device. Rod and President-Elect Jamie Franlin shall review options on this issue, for Jamie's year in office.

Youth Exchange: the decision cut-off is the end of October. Were the Club to move forward, like this year, President Rod wishes to have at least the initial Host Family fully in place before saying "yes." Howard Reed and Mike Graves shall solicit Outbound Exchange Student Candidates from our two high school Interact Clubs.

District Matching Grants are open for next year. Fig Garden Rotary has not in the past availed itself of this program and President Rod noted several creative options, while asking the Board to begin thinking about possible projects and partners.

Rod noted the successes of the Great Duck Races and the Annual Retreat, with kudos to Club Service leaders. He shall personally recognize individuals at an upcoming Friday meeting.

Regarding members with accounts in arrears, Rod is still working on the "policy" portion and is contacting personally those members with large outstanding balances. Three have already agreed to up payments, with the goal of zero balances by the end of the Rotary Year. Rod continues to contact these members on a one-on-one basis.

A discussion was held on the status of our Board Meeting's time and date, as two members have conflicts; it was decided to stay the course for this year. Jamie Franklin noted there will be a change next year.

Airport Rotary will host again a Prom at Florence Rata School. President Rod asked members to participate if so inclined.

The mentor for new Member Karen McMillan will be Judy Case.

There will be an Areawide All-Rotary Tailgate on October 25 at California State University, Fresno.

Jamie Franklin noted that the Bullard High School Theater was possibly just re-named. It was agreed that the Club would have naming rights as a recognition for our contributions. Jamie will research and report back.

*AVENUES OF SERVICE:

*Club Service: (August Hioco)

The Directors recently forwarded letters for each COG, reflecting upon responsibilities and opportunities afforded each. The following dates were reported for special activities:

*Club Service, Continued:

*9/25: COG Social At Dr. Coburn's Residence
*10/10: Day At The Races
*11/15: CSU Fresno Football Tailboate
*12/12: Gift Exchange
*12/14: Holiday At The Met (family focus)
*12/19: Basque Luncheon
*January: COG Party
*2/14: Roger Rocka's

*Community Service: (Steve Rontell and Jeff Oliver)

The Directors circulated a thank-you letter from the Salvation Army, with photos.

It was MSC to approve funding in the amount of \$6,000 for Big Brothers/Big Sisters for the "High School Mentoring Program."

It was MSC to approve funding in the amount of \$2,500. for the Trauma Intervention Programs, Inc. to create a "Citizen Resource Guide," which will carry the Fig Garden Rotary Club logo. The purchase is for two years' worth of supplies, for economies of scale. The Club had a recent program on this worthy organization's work.

*Vocational Service: (David Stepp and Matt Merzoian)

Regarding Job Shadowing:

- the date will be set shortly
- sign-ups soon will take place at Bullard High School
- as soon as the date is set, promotion will begin to our members

*International Service: (Howard Reed and Mike Graves)

A leaflet from Rotary International focusing on "Fellowship Exchange Programs" was circulated.

Howard noted that he and Mike will soon visit San Joaquin Memorial and Bullard High campuses, to promote Short-term Exchange Programs. The cost is \$1,600 per student.

It was MSC to fund two scholarships in the amount of \$800. each to subsidize 1/2 of the cost for each student.

Paul Harris Chair Tom Ogden joined the Board to present an extensive update on activities.

Fig Garden Rotary Club has funded a total of 164 Paul Harris Fellows and has 24 Benefactors. There are 38 Paul Harris Sustaining Members this year. The last Paul Harris Board was fully collected, the new system working well which collects monies prior to the Awards being ordered.

*International Service, continued:

Tom reviewed members' Paul Harris Accounts which are in question. The accounts, over the years, had been co-mingled with other Fig Garden Rotary monies and/or Rotary International made errors in posting. Jon Chessum worked diligently on this matter, as has Tom, and most of our members' accounts are now acceptable.

It was MSC to approve 587 Points to bring the following accounts to closure:

*Bob Abrams
*Scott Bristol
*Steve Rontell

Tom Wells' account reconciliation needs more information, which Tom Ogden will pursue.

There will be an updating of the Paul Harris Banner, which is displayed proudly at each of our Friday meetings.

Tom soon will send out an Account Statement to each of our members who participate in the Paul Harris Programs.

A Paul Harris Board will soon be done, with the resulting Fellowship being presented at the November 21, meeting with the District Governor.

*OLD BUSINESS:

No Old Business This Month.

*NEW BUSINESS:

No New Business This Month.

*ADJOURNMENT: Adjourned at 8:31 a.m. by President Rod Coburn.

*NEXT MEETING: 15 October 2003

Respectfully Submitted By Doug Cords, Ph.D., Secretary.

Rotary Club of Fig Garden

Club Accounts

Balance sheet for period ending 31 August 03

Printed 9/15/03

ACCUMULATED FUNDS

Club Funds

Balance at beginning of year	\$55,806.20
Excess (Deficit) for period	\$4,047.81
Balance to Date	\$59,854.01

TOTAL FUNDS	<u>\$59,854.01</u>
--------------------	--------------------

Represented by:

ASSETS

Checking Account-Cal Fed	\$10,534.48
Morgan Stanley Dean Witter	\$26,666.59
Member's Current Accounts	\$19,702.94
Note Rec - Playland	\$5,000.00
Total Assets	<u>\$61,904.01</u>

LIABILITIES

Foundation Payable	\$500.00
PHF Clearing	\$50.00
Woodward Park Bench Project	\$1,500.00
Total Liabilities	<u>\$2,050.00</u>

NET ASSETS	<u>\$59,854.01</u>
-------------------	--------------------

Rotary Club of Fig Garden

Club Accounts

Income & Expenditure: Current Month & Year to Date to August 03

Printed 9/15/03

	Current Month	Year to Date
INCOME		
Member Dues	(\$125.00)	\$11,500.00
Fines	(\$50.00)	(\$50.00)
Raffle	\$197.00	\$197.00
Demotion Party	\$0.00	\$150.00
Offsite Lunches	\$890.00	\$890.00
Miscellaneous Income	\$500.00	\$574.13
Total Income	\$1,412.00	\$13,261.13
EXPENDITURE		
R.I. Dues	\$3,014.85	\$3,014.85
District Dues	\$2,486.76	\$2,486.76
Supplies and Postage	\$43.79	\$43.79
Miscellaneous Expense	\$340.48	\$340.48
Speakers	\$505.44	\$505.44
Demotion Party	\$0.00	\$75.00
Duck Races	\$1,837.00	\$1,837.00
Retreat	\$900.00	\$900.00
Offsite Lunches	\$0.00	\$10.00
Total Expenditure	\$9,128.32	\$9,213.32
Excess (Deficit)	(\$7,716.32)	\$4,047.81

Rotary Club of Fig Garden

Club Accounts

Income & Expenditure: Current Year vs Previous Year to August 03

Printed 9/15/03

	Month		Year to Date	
	Current Year	Previous Year	Current Year	Previous Year
INCOME				
Member Dues	(\$125.00)	\$0.00	\$11,500.00	\$13,500.00
Fines	(\$50.00)	\$0.00	(\$50.00)	\$0.00
Raffle	\$197.00	\$0.00	\$197.00	\$186.00
Demotion Party	\$0.00	\$0.00	\$150.00	\$0.00
Roger Rockas	\$0.00	\$0.00	\$0.00	\$76.00
Offsite Lunches	\$890.00	\$0.00	\$890.00	\$0.00
Miscellaneous Income	\$500.00	\$0.00	\$574.13	\$235.00
Total Income	\$1,412.00	\$0.00	\$13,261.13	\$13,997.00
EXPENDITURE				
R.I. Dues	\$3,014.85	\$0.00	\$3,014.85	\$3,133.75
District Dues	\$2,486.76	\$0.00	\$2,486.76	\$0.00
Supplies and Postage	\$43.79	\$0.00	\$43.79	\$0.00
Computer Expenses and Web Site	\$0.00	\$0.00	\$0.00	\$522.00
Miscellaneous Expense	\$340.48	\$0.00	\$340.48	\$527.50
Bank Charges	\$0.00	\$4.00	\$0.00	\$4.00
Speakers	\$505.44	\$0.00	\$505.44	\$0.00
Demotion Party	\$0.00	\$0.00	\$75.00	\$0.00
Hospitality and Fellowship	\$0.00	\$50.00	\$0.00	(\$150.00)
Duck Races	\$1,837.00	\$0.00	\$1,837.00	\$0.00
Retreat	\$900.00	\$0.00	\$900.00	\$0.00
Mystery Dinner	\$0.00	\$0.00	\$0.00	\$34.62
Offsite Lunches	\$0.00	\$0.00	\$10.00	\$0.00
Camp Royal	\$0.00	\$0.00	\$0.00	(\$58.38)
Fresno City College Scholarships	\$0.00	\$1,000.00	\$0.00	\$1,000.00
Total Expenditure	\$9,128.32	\$1,054.00	\$9,213.32	\$5,013.49
Excess (Deficit)	(\$7,716.32)	(\$1,054.00)	\$4,047.81	\$8,983.51

Rotary Club of Fig Garden

Club Accounts

Income & Expenditure: Comparison to Budget to August 03

Printed 9/15/03

	Current Month	Year to Date	Budget to Date	Variance
INCOME				
Member Dues	(\$125.00)	\$11,500.00	\$14,000.00	(\$2,500.00)
Admin Charge-New Members	\$0.00	\$0.00	\$200.00	(\$200.00)
Fines	(\$50.00)	(\$50.00)	\$0.00	(\$50.00)
Raffle	\$197.00	\$197.00	\$200.00	(\$3.00)
Interest	\$0.00	\$0.00	\$100.00	(\$100.00)
Demotion Party	\$0.00	\$150.00	\$0.00	\$150.00
Offsite Lunches	\$890.00	\$890.00	\$300.00	\$590.00
Miscellaneous Income	\$500.00	\$574.13	\$100.00	\$474.13
Total Income	\$1,412.00	\$13,261.13	\$14,900.00	(\$1,638.87)
EXPENDITURE				
R.I. Dues	\$3,014.85	\$3,014.85	\$2,900.00	(\$114.85)
District Dues	\$2,486.76	\$2,486.76	\$2,900.00	\$413.24
Supplies and Postage	\$43.79	\$43.79	\$300.00	\$256.21
Computer Expenses and Web Site	\$0.00	\$0.00	\$60.00	\$60.00
Officer Expense	\$0.00	\$0.00	\$200.00	\$200.00
Miscellaneous Expense	\$340.48	\$340.48	\$300.00	(\$40.48)
Bank Charges	\$0.00	\$0.00	\$30.00	\$30.00
Lunch-Tornino's	\$0.00	\$0.00	\$300.00	\$300.00
Programs	\$0.00	\$0.00	\$100.00	\$100.00
Speakers	\$505.44	\$505.44	\$150.00	(\$355.44)
Demotion Party	\$0.00	\$75.00	\$0.00	(\$75.00)
Bulletin	\$0.00	\$0.00	\$50.00	\$50.00
Banners, Badges, Pins	\$0.00	\$0.00	\$100.00	\$100.00
Hospitality and Fellowship	\$0.00	\$0.00	\$650.00	\$650.00
Blue Book	\$0.00	\$0.00	\$150.00	\$150.00
Rotary Information	\$0.00	\$0.00	\$50.00	\$50.00
Membership	\$0.00	\$0.00	\$100.00	\$100.00
Duck Races	\$1,837.00	\$1,837.00	\$0.00	(\$1,837.00)
Retreat	\$900.00	\$900.00	\$0.00	(\$900.00)
Field Trips	\$0.00	\$0.00	\$200.00	\$200.00
Offsite Lunches	\$0.00	\$10.00	\$0.00	(\$10.00)
Community Projects	\$0.00	\$0.00	\$250.00	\$250.00
Bullard Interact	\$0.00	\$0.00	\$50.00	\$50.00
SJM Interact	\$0.00	\$0.00	\$50.00	\$50.00
Youth Exchange	\$0.00	\$0.00	\$50.00	\$50.00
Paul Harris	\$0.00	\$0.00	\$250.00	\$250.00
Total Expenditure	\$9,128.32	\$9,213.32	\$9,190.00	(\$23.32)
Excess (Deficit)	(\$7,716.32)	\$4,047.81	\$5,710.00	(\$1,615.55)

FIG GARDEN ROTARY CLUB

FOUNDATION

BOARD OF DIRECTORS

*Regular Meeting: 17 September 2003:

*Members Present:

*Directors:

Mike Graves
August Hioco
Matt Merzoian
Jeff Oliver
Howard Reed
Steve Rontell
David Stepp

*Foundation Treasurer:

Jeff Garza

*Treasurer:

Scott Bristol

*Secretary:

Doug Cords

*President:

Rod Coburn

*Other(s) Present:

*President-Elect:

Jamie Franklin

Paul Harris Chair Tom Ogden

The meeting was called to concurrent order with the Regular Board Meeting of the Fig Garden Rotary Club by President Rod Coburn in the Boardroom of the Stoughton Davidson Accountancy Corporation at 2530 West Shaw Lane, Suite 101, Fresno, California at 7:02 a.m.

*TREASURER'S REPORT:

(Jeff Garza)

Jeff presented to the Board figures ending July 31, 2003, including Net Worth, Income and Expenses, Portfolio Value and Community Service Expenses Year-to-Date—a new format was presented, reflecting much work and effort on the part of the Foundation Treasurer, the result of which is much more clarity and readability.

The only liability is the sum of \$2,365., to remit to Rotary International for Paul Harris payments.

*Accounts:

*Unrestricted Funds:	\$117,641.
*Permanent Funds:	153,822.
*Totals:	<u>\$271,463.</u>

Jeff reviewed Income and Expenses; a Portfolio gain of \$14,515 was reported. He also reviewed UBS' printout of the Permanent Fund Account, from Paul Sahota. The goal is to have 70% in equities and 30% in fixed income investments.

It was MSC to approve the Treasurer's Report as presented.

Jeff will add to the Portfolio Report information to include date when fund was purchased and cost.

The Board expressed its sincere thanks to the Treasurer for coming up to speed in a new capacity so well.

*ADJOURNMENT: Concurrent With Regular Meeting, Adjourned By President Rod Coburn at 8:31 a.m.

*NEXT MEETING: 15 October 2003

Respectfully Submitted By Doug Cords, Ph.D., Foundation Secretary.

Net Worth
(Includes unrealized gains)
As of 8/31/2003

9/15/2003

Page 1

Account	7/31/2003 Balance	8/31/2003 Balance
ASSETS		
Cash and Bank Accounts		
UBS Savings-Cash	90,727.62	90,763.91
WM Checking	25,727.31	26,877.13
TOTAL Cash and Bank Accounts	<u>116,454.93</u>	<u>117,641.04</u>
Investments		
UBS Permanent Fund	150,369.64	153,822.75
UBS Savings	0.00	0.00
TOTAL Investments	<u>150,369.64</u>	<u>153,822.75</u>
TOTAL ASSETS	<u>266,824.57</u>	<u>271,463.79</u>
LIABILITIES		
Other Liabilities		
Paul Harris Receipts Due RI	520.00	2,365.00
TOTAL Other Liabilities	<u>520.00</u>	<u>2,365.00</u>
TOTAL LIABILITIES	<u>520.00</u>	<u>2,365.00</u>
OVERALL TOTAL	<u>266,304.57</u>	<u>269,098.79</u>

Fig Garden Rotary Foundation
7/1/2003 Through 6/30/2004 Using My Budget

9/16/2003

Page 1

Category Description	7/1/2003 Actual	- Budget	6/30/2004 Difference
INCOME			
Auction 2004	0.00	75,000.00	-75,000.00
Clear Channel Donations	0.00	20,000.00	-20,000.00
Contributions from Club	0.00	10,000.00	-10,000.00
Earnings from Perm Fund	0.00	400.00	-400.00
Interest Inc	77.44	0.00	77.44
TOTAL INCOME	77.44	105,400.00	-105,322.56
EXPENSES			
Administrative Exps	0.00	25.00	25.00
Auction 2005 Expenses	0.00	19,500.00	19,500.00
Community Service	0.00	0.00	0.00
Community Service Donations 2003-2004	4,532.00	55,000.00	50,468.00
TOTAL Community Service	4,532.00	55,000.00	50,468.00
Contributions to PF FGFR	0.00	10,000.00	10,000.00
International Service	0.00	5,000.00	5,000.00
Misc Donations	0.00	500.00	500.00
Polio Plus	0.00	5,250.00	5,250.00
Vocational Service	0.00	5,000.00	5,000.00
Vocational Scholarships	0.00	5,000.00	5,000.00
TOTAL Vocational Service	0.00	10,000.00	10,000.00
TOTAL EXPENSES	4,532.00	105,275.00	100,743.00
OVERALL TOTAL	-4,454.56	125.00	-4,579.56

Portfolio Value

As of 8/31/2003

9/14/2003

Page 1

Security	Shares	Price	est	Cost Basis	Pre-Tax Gain	Balance
CD Discover Bnk 2.50% 11/...	120.000	100.000	*	12,000.00	0.00	12,000.00
CD Ind Bnk East 2.00% 10/2...	130.000	100.000	*	12,973.87	26.13	13,000.00
CD Key Bnk 3.10% 11/08/05	130.000	100.000	*	13,000.00	0.00	13,000.00
CD Pan Am Bnk 3.65% 10/3...	130.000	100.000	*	12,930.84	69.16	13,000.00
Growth Fund of America	439.312	22.410		9,199.20	645.78	9,844.98
Income Fund of America	465.000	15.650		6,628.53	648.72	7,277.25
Liberty Acorn	982.000	19.670		15,172.30	4,143.64	19,315.94
Pimco Small Cap Value	808.000	22.840		16,081.84	2,372.88	18,454.72
Pimco Value Fund	1,468.000	13.630		16,084.70	3,924.14	20,008.84
Templeton Foreign	2,020.000	9.610		16,727.00	2,685.20	19,412.20
-Cash-				99,272.73	0.00	99,272.73
TOTAL Investments				230,071.01	14,515.65	244,586.66

FGRF-Community Service Donations YTD

7/1/2003 Through 8/31/2003

9/16/2003

Page 1

Cat/Sub	Date	Description	Memo	Amount
EXPENSES				
Community Service				
Community Service Donations...				
	7/18/2...	Fresno Survivors of Suicide	Board Mtg 7/16/03	-1,222.00
	7/18/2...	Salvation Army	Board Mtg 7/16/03	-550.00
	7/18/2...	Sequoia Council of Boy Scouts	Board Mtg 7/16/03	-1,000.00
	7/18/2...	Criminal Justice Advocates	Board Mtg 7/16/03	-1,060.00
	8/20/2...	Housing League of Fresno	Operation School Bell	-700.00
				-4,532.00
TOTAL Community Service D...		<i>Assistance.</i>		-4,532.00
TOTAL Community Service				-4,532.00
TOTAL EXPENSES				-4,532.00
OVERALL TOTAL				-4,532.00

Fig Garden Rotary Endowment Account

Asset Allocation

US Large Co. Equity	\$ 27,286.09	17.69%
US Med/Sm Co. Equity	\$ 37,770.66	24.49%
Int'l Equity	\$ 19,412.20	12.59%
Int'l Fixed Income	\$ -	0.00%
US Fixed Income	\$ 51,387.98	33.32%
Cash / M.M	\$ 8,508.82	5.52%
	\$ 154,210.73	100.00%

Account Allocation

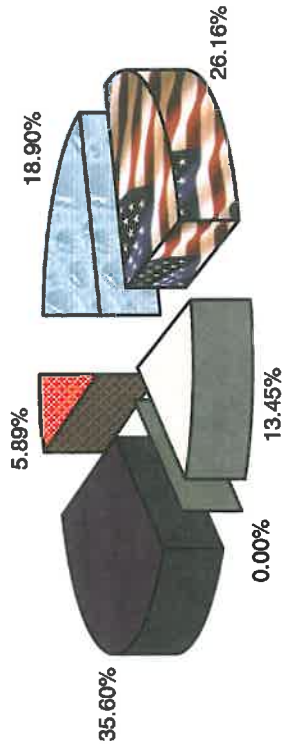

<input type="checkbox"/> US Large Co. Equity	<input checked="" type="checkbox"/> US Med/Sm Co. Equity
<input type="checkbox"/> Int'l Equity	<input type="checkbox"/> Int'l Fixed Income
<input checked="" type="checkbox"/> US Fixed Income	<input checked="" type="checkbox"/> Cash / M.M



Investment Holdings

	Cost		Value	Percent Gain / loss
	Basis	8/31/2003	8/31/2003	
<u>US Large Co. Equity:</u>				
Income Fund of America	\$ 6,630.40	\$ 7,277.25	9.76%	
Pimco Value Fund	\$ 16,087.34	\$ 20,008.84	24.38%	
Growth Fund of America	\$ 9,199.20	\$ 9,844.98	7.02%	
<u>US Med/Sm Co. Equity:</u>				
Liberty Acorn Fund	\$ 15,174.53	\$ 19,315.94	27.29%	
Pimco Small Cap Value	\$ 16,083.37	\$ 18,454.72	14.74%	
<u>Int'l Equity</u>				
Templeton Foreign	\$ 16,729.41	\$ 19,412.20	16.04%	
<u>US & Int'l Fixed Income:</u>				
CD Independent Bank 2% due 10/23/03	\$ 12,973.87	\$ 12,998.70	0.19%	
CD Discover Bank 2.5% due 11/08/04	\$ 12,000.00	\$ 12,105.36	0.88%	
CD Key Bank & Trust 3.1% due 11/08/05	\$ 13,000.00	\$ 13,109.46	0.84%	
CD Pan American Bank 3.65% due 10/30/06	\$ 12,930.84	\$ 13,174.46	1.88%	
<u>Cash / Money Market:</u>				
Money Market	\$ 8,508.82	\$ 8,508.82	0.00%	
TOTAL PORTFOLIO	\$ 139,317.78	\$ 154,210.73	10.69%	
Cash & Cash Equivalents				
	\$ 8,508.82	\$ 8,508.82		
Total Securities	\$ 121,767.07	\$ 145,701.91		

Foundation Account Value \$ 90,763.91

Paul Sahota
Financial Advisor

This is not an actual Statement.
Strictly for illustrative purposes only.

ROTARY CLUB OF FIG GARDEN

BOARD OF DIRECTORS

*Regular Meeting: 15 October 2003 --

*Members Present:

*Directors:

August Hioco
Matt Merzoian
Howard Reed
Steve Rontell
Steve Wilson

*Past President:

Eric Fogderude

*Treasurer:

Scott Bristol

*Other(s) Present:

Joetta Winters

*President:

Rod Coburn

*Foundation Treasurer:

Jeff Garza

*President-Elect:

Jamie Franklin

*Secretary:

Doug Cords

The meeting was called to order by President Rod Coburn at 7:06 a.m. in the Boardroom of the Stoughton Davidson Accountancy Corporation at 2530 West Shaw Lane, Fresno, California 93711.

[Beginning Note: Director Mike Graves is automatically terminated from the Board Of Directors, per By-Laws, by virtue of this being his third missed meeting]

*CONSENT ITEMS:

*Minutes Of The Regular Meeting Of 17 September 2003		
*Attendance For The Month Of September 2003	=	83%
*Membership As Of 1 October 2003	=	104

It was MSC to approve the Consent Items as presented.

*TREASURER'S REPORT: (Scott Bristol)

Scott noted that fines will be posted into the System shortly.

The Treasurer reviewed key accounts, as follows:

-Cal Fed:	\$14,261.
-Morgan Stanley	26,666.
-Members' Accounts Receivable:	15,679.
-Playland/Storyland Note:	5,000.

A review was presented of current Income and Expenses. The Annual Retreat did not cost extra funds this year. Scott reviewed Members' Accounts and discussion ensued regarding members' annual fees, Rotary International dues, District dues and insurance costs.

It was MSC to approve the Treasurer's Report as presented.

*SECRETARY'S REPORT:

(Doug Cords)

Past President Allen Taylor, through a phone conversation and letter with President Coburn, has asked for an "Excuse From Club Attendance Requirements," to begin immediately and run to 31 March 2004. It was MSC to approve the request, after the Secretary reviewed for the Board criteria for the decision.

Extensive discussion ensued regarding ways to encourage members who are away for a time to continue to participate (when possible) in Club meetings and other functions. Keeping the member "connected" is a key focus for a desirable outcome.

The Board expressed appreciation to Joetta Winter for her yeoman's job with Youth Exchange Volunteerism. Joetta led a discussion on possible ways to enhance the student's experience vis-a-vis school enrollment.

The Board again thanks Scott Bristol and Stoughton Davidson Accountancy Corporation for its gracious hosting of our Board meetings each month.

The Secretary reviewed members with extreme attendance problems. The procedure, when a problem is identified, is to contact the member with a kind, encouraging personal note asking about make-ups and a call to the Secretary. Gib Hutchings and John Blanchfield responded promptly and are working out difficulties. Mitch Akbiyikian and Tom Isaac did not respond. Mitch was called and indicated a lack of time/interest and Tom has not responded to calls. The Secretary has terminated the membership of Mitch Akbiyikian due to the 4-Missed-Meetings-In-A-Row provision, as no interest in making up was displayed.

Recently inducted into Fig Garden Rotary Club were:

- *Karen McMillan
- *Roy Massey (Past District Governor)
- *Robin Baldwin (Past President, Returning)

New Member Proposals:

KERRI DONIS

Sponsors are Dave Holden and Matt Merzoian
Kerri is a Captain in the Fresno Fire Department
Membership Committee has approved
Proposed Classification: Public Safety - Fire Department Management

It was MSC to approve the Nomination.

JENNIFER WILLIAMS

Sponsors are Roy Massey and Doug Cords
Jennifer is Assistant Agency Manager with Guardian Insurance
Membership Committee has approved
Proposed Classification: Insurance - Agency Recruitment

It was MSC to approve the Nomination.

Secretary to promptly forward Nominations to Rotary Information Committee.

*SECRETARY'S REPORT, Continued:

President-Elect Jamie Franklin led a discussion to make certain that all proper protocols and procedures were being followed in the nomination of any new member and such is the case, always.

Former Member Doug Holton will be returning to the Club shortly. He is now employed with Temecula Valley Bank and, per previous Board approval, will come back to Fig Garden Rotary Club without the "normal" COG duties and/or costs. Secretary to provide the new information to Classification promptly.

With four months into the Rotary year completed, the Membership Committee has produced no visible recruiting results. At any given time, we have 10-12 members "on the bubble" with attendance problems, any of whom could be disqualified. President Rod and President-Elect Jamie will receive this list from the Secretary, to continue with club follow-ups.

*PRESIDENT-ELECT'S REPORT: (Jamie Franklin)

Joining Doug Brinkley and David Bonnar will be Greg Baxter, as the third "kingpin" in the Auction Leadership Group, with Greg working as Merchandise Chair.

Jamie provided an update to the Ecuadorian wheelchair project. The country requires an independent customs review of any import, to be done in the exporting country. This step is in progress, in China.

Mike Graves will be involved in next year's possible Youth Exchange, a follow-up report will be presented shortly to the Board.

*PAST PRESIDENT'S REPORT: (Eric Fogderude)

John Blanchfield is currently finishing up the individual pages for the "new" format Blue Book; the binders are in Bill Griffith's possession.

Eric gave a mini-review of computer equipment and software; some hardware is apparently "in storage" at Storyland. Steve Rontell (current Playland/Storyland Director) and Doug Cords (former Director) expressed concern over the security and safety of the assets. They will be removed as soon as possible from this venue and stored at the Torcaso facility wherein the club stores Auction Merchandise.

*PRESIDENT'S TIME: (Rod Coburn)

This coming Friday meeting, October 17th, will have Tom Ogden discussing the Foundation and Robin Baldwin presenting "Rotary Protocol," a much-needed topic.

Lorna Bonyhadi wrote a special thank you note for consideration and care afforded following her Mother's passing away. Bob Abrams continues with his superb job in this arena of Club services.

The President will cover "arrears" of members in a future meeting. Many have been contacted and some are making additional payments.

*PRESIDENT'S TIME, Continued:

Mary Lou Gunn has been asked for Clear Channel Communications events for next year, so the Club can "staff up" effectively to serve and to earn the huge donations given over the years.

The District Govern's Visit is 21 November.

The District Conference, at Tenaya Lodge, will be in the end of April, and all members are encouraged to participate.

Rod reviewed the recent "Day At The Races," with especial thanks to August Hioco and Steve Wilson for their leadership.

*AVENUES OF SERVICE:

-Club Service: (August Hioco and Steve Wilson)

The recent COG Social was both productive and very enjoyable for all.

15 November is the Tailgate; COGS will be cooks and monies will be pre-collected, if possible.

Matt Merzoian and Scott Bristol shall look into the feasibility of the Club having a credit card program for payments.

14 December is the Holiday At The Met, a time for families to enjoy.

August is preparing a "Director's Notebook" of all Club Service arenas, to present to future Directors for their effective management of this Avenue Of Service.

-Community Service: (Steve Rontell)

It was MSC to approve funding in the amount of \$1,200. for a "Gold Membership" with Crime Stoppers.

It was MSC to approve funding in the amount of \$500. for a "Bomb Sniffing Canine" Project with the Fresno Police Department.

It was MSC to approve funding in the amount of \$3,000. for the Raymacher School, pre-designed funds for funding for a handicapped playground project; these funds emanated from Clear Channel Communications' donation and were earmarked for this project soley.

It was MSC to approve funding of up to \$2,000. for the Holiday Gift Basket Program.

A thank you letter was circulated for our donation of \$6,000 to Big Brothers/Big Sisters.

-Vocational Service: (Matt Merzoian)

Matt reviewed the Job Shadowing Program's progress to date, and shared frustration at the lack of communication from the Bullard High School contact; further work will be done to make this event a success.

*AVENUES OF SERVICE, Continued:

-International Service: (Howard Reed)

This coming weekend, 24-26 October, offers a "hosting opportunity" for our Exchange Student, as her host family will be out of town.

The Club still needs a Host Family for the final segment, May-July.

Marie soon will be able to make a presentation to the Club, as her English skills are good and improving rapidly.

*OLD BUSINESS:

Steve Rontell presented an overview of Playland and Storyland activities, directed at generating more funds; they are not ready to present plans for repayment schedule for the \$5,000 note. President Rod asked that a letter delineating plans and a repayment schedule be submitted to the Board for inclusion in the Minutes. Steve shall ask Deryl Bear and/or Greg Baxter to write the letter.

*NEW BUSINESS:

Dr. Coburn asked the Board to generate ideas for something special under the District Governor's "The Yellow Brick Road" theme for his visitation, perhaps a skit.

*ADJOURNMENT: The President adjourned the meeting at 8:45 a.m.

*NEXT MEETING: 19 November 2003

Respectfully Submitted By Doug Cords, Ph.D., Club Secretary.

Rotary Club of Fig Garden

Club Accounts

Balance sheet for period ending 30 September 03

Printed 10/15/03

ACCUMULATED FUNDS

Club Funds

Balance at beginning of year	\$55,806.20
Excess (Deficit) for period	\$3,650.75
Balance to Date	\$59,456.95

TOTAL FUNDS

\$59,456.95

Represented by:

ASSETS

Checking Account-Cal Fed	\$14,261.17
Morgan Stanley Dean Witter	\$26,666.59
Member's Current Accounts	\$15,679.19
Note Rec - Playland	\$5,000.00
Total Assets	<u>\$61,606.95</u>

LIABILITIES

Foundation Payable	\$500.00
PHF Clearing	\$150.00
Woodward Park Bench Project	\$1,500.00
Total Liabilities	<u>\$2,150.00</u>

NET ASSETS

\$59,456.95

Rotary Club of Fig Garden

Club Accounts

Income & Expenditure: Current Month & Year to Date to September 03

Printed 10/13/03

	Current Month	Year to Date
INCOME		
Member Dues	\$250.00	\$11,750.00
Admin Charge-New Members	\$160.00	\$160.00
Fines	\$0.00	(\$50.00)
Raffle	\$105.00	\$302.00
Demotion Party	\$0.00	\$150.00
Retreat	\$3,705.50	\$3,705.50
Offsite Lunches	\$0.00	\$890.00
Miscellaneous Income	\$102.70	\$676.83
Total Income	\$4,323.20	\$17,584.33
EXPENDITURE		
R.I. Dues	\$0.00	\$3,014.85
District Dues	\$0.00	\$2,486.76
Supplies and Postage	\$151.97	\$195.76
Miscellaneous Expense	\$0.00	\$340.48
Speakers	\$0.00	\$505.44
Demotion Party	\$0.00	\$75.00
Banners, Badges, Pins	\$787.06	\$787.06
Duck Races	\$0.00	\$1,837.00
Retreat	\$3,481.23	\$4,381.23
Offsite Lunches	\$0.00	\$10.00
Youth Exchange	\$300.00	\$300.00
Total Expenditure	\$4,720.26	\$13,933.58
Excess (Deficit)	(\$397.06)	\$3,650.75

Rotary Club of Fig Garden

Club Accounts

Income & Expenditure: Comparison to Budget to September 03

Printed 10/13/03

	Current Month	Year to Date	Budget to Date	Variance
INCOME				
Member Dues	\$250.00	\$11,750.00	\$14,000.00	(\$2,250.00)
Admin Charge-New Members	\$160.00	\$160.00	\$300.00	(\$140.00)
Fines	\$0.00	(\$50.00)	\$5,000.00	(\$5,050.00)
Raffle	\$105.00	\$302.00	\$300.00	\$2.00
Interest	\$0.00	\$0.00	\$150.00	(\$150.00)
Demotion Party	\$0.00	\$150.00	\$0.00	\$150.00
Retreat	\$3,705.50	\$3,705.50	\$0.00	\$3,705.50
Offsite Lunches	\$0.00	\$890.00	\$450.00	\$440.00
Miscellaneous Income	\$102.70	\$676.83	\$150.00	\$526.83
Total Income	\$4,323.20	\$17,584.33	\$20,350.00	(\$2,765.67)
EXPENDITURE				
R.I. Dues	\$0.00	\$3,014.85	\$2,900.00	(\$114.85)
District Dues	\$0.00	\$2,486.76	\$2,900.00	\$413.24
Supplies and Postage	\$151.97	\$195.76	\$450.00	\$254.24
Computer Expenses and Web Site	\$0.00	\$0.00	\$90.00	\$90.00
Officer Expense	\$0.00	\$0.00	\$300.00	\$300.00
Terminated Members	\$0.00	\$0.00	\$400.00	\$400.00
Miscellaneous Expense	\$0.00	\$340.48	\$450.00	\$109.52
Bank Charges	\$0.00	\$0.00	\$45.00	\$45.00
Lunch-Tornino's	\$0.00	\$0.00	\$450.00	\$450.00
Programs	\$0.00	\$0.00	\$150.00	\$150.00
Speakers	\$0.00	\$505.44	\$225.00	(\$280.44)
Demotion Party	\$0.00	\$75.00	\$0.00	(\$75.00)
Bulletin	\$0.00	\$0.00	\$75.00	\$75.00
Banners, Badges, Pins	\$787.06	\$787.06	\$150.00	(\$637.06)
Hospitality and Fellowship	\$0.00	\$0.00	\$975.00	\$975.00
Blue Book	\$0.00	\$0.00	\$225.00	\$225.00
Rotary Information	\$0.00	\$0.00	\$75.00	\$75.00
Membership	\$0.00	\$0.00	\$150.00	\$150.00
Duck Races	\$0.00	\$1,837.00	\$0.00	(\$1,837.00)
Retreat	\$3,481.23	\$4,381.23	\$6,000.00	\$1,618.77
Field Trips	\$0.00	\$0.00	\$300.00	\$300.00
Offsite Lunches	\$0.00	\$10.00	\$0.00	(\$10.00)
Community Projects	\$0.00	\$0.00	\$375.00	\$375.00
Bullard Interact	\$0.00	\$0.00	\$75.00	\$75.00
SJM Interact	\$0.00	\$0.00	\$75.00	\$75.00
Youth Exchange	\$300.00	\$300.00	\$75.00	(\$225.00)
Paul Harris	\$0.00	\$0.00	\$375.00	\$375.00
Total Expenditure	\$4,720.26	\$13,933.58	\$17,285.00	\$3,351.42
Excess (Deficit)	(\$397.06)	\$3,650.75	\$3,065.00	(\$6,117.09)

Rotary Club of Fig Garden

Club Accounts

Income & Expenditure: Current Year vs Previous Year to September 03

Printed 10/13/03

	Month		Year to Date	
	Current Year	Previous Year	Current Year	Previous Year
INCOME				
Member Dues	\$250.00	\$0.00	\$11,750.00	\$13,500.00
Admin Charge-New Members	\$160.00	\$0.00	\$160.00	\$0.00
Fines	\$0.00	\$5,831.25	(\$50.00)	\$5,831.25
Raffle	\$105.00	\$126.00	\$302.00	\$312.00
Interest	\$0.00	\$54.46	\$0.00	\$54.46
Demotion Party	\$0.00	\$0.00	\$150.00	\$0.00
Roger Rockas	\$0.00	\$0.00	\$0.00	\$76.00
Retreat	\$3,705.50	\$0.00	\$3,705.50	\$0.00
Offsite Lunches	\$0.00	\$0.00	\$890.00	\$0.00
Miscellaneous Income	\$102.70	\$685.00	\$676.83	\$920.00
Total Income	\$4,323.20	\$6,696.71	\$17,584.33	\$20,693.71
EXPENDITURE				
R.I. Dues	\$0.00	\$0.00	\$3,014.85	\$3,133.75
District Dues	\$0.00	\$2,657.42	\$2,486.76	\$2,657.42
Supplies and Postage	\$151.97	\$458.11	\$195.76	\$458.11
Computer Expenses and Web Site	\$0.00	\$0.00	\$0.00	\$522.00
Terminated Members	\$0.00	\$250.00	\$0.00	\$250.00
Miscellaneous Expense	\$0.00	\$0.00	\$340.48	\$527.50
Bank Charges	\$0.00	\$0.00	\$0.00	\$4.00
Lunch-Tornino's	\$0.00	\$333.50	\$0.00	\$333.50
Speakers	\$0.00	\$0.00	\$505.44	\$0.00
Demotion Party	\$0.00	\$512.52	\$75.00	\$512.52
Banners, Badges, Pins	\$787.06	\$384.43	\$787.06	\$384.43
Hospitality and Fellowship	\$0.00	\$1,325.46	\$0.00	\$1,175.46
Duck Races	\$0.00	\$0.00	\$1,837.00	\$0.00
Retreat	\$3,481.23	\$0.00	\$4,381.23	\$0.00
Mystery Dinner	\$0.00	\$0.00	\$0.00	\$34.62
Offsite Lunches	\$0.00	\$0.00	\$10.00	\$0.00
Camp Royal	\$0.00	\$0.00	\$0.00	(\$58.38)
Fresno City College Scholarships	\$0.00	(\$1,000.00)	\$0.00	\$0.00
Youth Exchange	\$300.00	\$0.00	\$300.00	\$0.00
Total Expenditure	\$4,720.26	\$4,921.44	\$13,933.58	\$9,934.93
Excess (Deficit)	(\$397.06)	\$1,775.27	\$3,650.75	\$10,758.78

Rotary Club of Fig Garden

Club Accounts

Accounting Audit Report: 9/ 1/03 to 9/30/03

Printed 10/13/03

Code	Date	Amount Ref	Description	GL Account
CP Bank Withdrawals				
CP-1659-0000	9/ 6/03	(\$300.00) Chk 1504	Payment: Howard Reed	1-6110 Checking Account-Cal Fed
CP-1659-0001	9/ 6/03	\$300.00 Chk 1504	Three months stipend for Marie Miyazaki	1-3505 Youth Exchange
CP-1660-0000	9/ 8/03	(\$151.97) Chk 1505	Payment: Wendy Cords	1-6110 Checking Account-Cal Fed
CP-1660-0001	9/ 8/03	\$151.97 Chk 1505	Office supplies.	1-3015 Supplies and Postage
CP-1661-0000	9/ 8/03	(\$1,469.90) Chk 1506	Payment: The Redwoods	1-6110 Checking Account-Cal Fed
CP-1661-0001	9/ 8/03	\$1,469.90 Chk 1506	Retreat cabins	1-3148 Retreat
CP-1662-0000	9/ 8/03	(\$556.67) Chk 1507	Payment: Old Doc's	1-6110 Checking Account-Cal Fed
CP-1662-0001	9/ 8/03	\$556.67 Chk 1507	Retreat refreshments	1-3148 Retreat
CP-1663-0000	9/10/03	(\$500.00) Chk 1508	Payment: Cigar's Ltd.	1-6110 Checking Account-Cal Fed
CP-1663-0001	9/10/03	\$500.00 Chk 1508	Cigars for the retreat	1-3148 Retreat
CP-1664-0000	9/15/03	(\$480.90) Chk 1509	Payment: Scott Bristol	1-6110 Checking Account-Cal Fed
CP-1664-0001	9/15/03	\$480.90 Chk 1509	Reimbursement for golf for the Retreat	1-3148 Retreat
CP-1665-0000	9/22/03	(\$787.06) Chk 1510	Payment: Russell Hampton and Co.	1-6110 Checking Account-Cal Fed
CP-1665-0001	9/22/03	\$787.06 Chk 1510	Banners, badges and pins,etc	1-3125 Banners, Badges, Pins
CP-1666-0000	9/23/03	(\$473.76) Chk 1511	Payment: Brad Smith	1-6110 Checking Account-Cal Fed
CP-1666-0001	9/23/03	\$473.76 Chk 1511	Food for the Retreat	1-3148 Retreat
		\$0.00		
CR Bank Deposits				
CR-1657-0000	9/ 9/03	\$3,250.75 CR-1657	Bank Deposit: \$3250.75	1-6110 Checking Account-Cal Fed
CR-1657-0001	9/ 9/03	(\$250.00) CR-1657	Receipt: AZNAVOORIAN, John	1-6510 Member's Current Accounts
CR-1657-0002	9/ 9/03	(\$125.00) CR-1657	Receipt: ARCHER, Dennis	1-6510 Member's Current Accounts
CR-1657-0003	9/ 9/03	(\$275.00) CR-1657	Receipt: COBURN, Rod	1-6510 Member's Current Accounts
CR-1657-0004	9/ 9/03	(\$250.00) CR-1657	Receipt: ELLIS, Sonja	1-6510 Member's Current Accounts
CR-1657-0005	9/ 9/03	(\$250.00) CR-1657	Receipt: FEDERICO, Sam	1-6510 Member's Current Accounts
CR-1657-0006	9/ 9/03	(\$200.00) CR-1657	Receipt: GIBBS, Jim	1-6510 Member's Current Accounts
CR-1657-0007	9/ 9/03	(\$260.00) CR-1657	Receipt: POUND III, Tripp	1-6510 Member's Current Accounts
CR-1657-0008	9/ 9/03	(\$260.00) CR-1657	Receipt: RIANDA, Stacy	1-6510 Member's Current Accounts
CR-1657-0009	9/ 9/03	(\$125.00) CR-1657	Receipt: RIMMER, Rod	1-6510 Member's Current Accounts
CR-1657-0010	9/ 9/03	(\$125.00) CR-1657	Receipt: SEGAL, Wes	1-6510 Member's Current Accounts
CR-1657-0011	9/ 9/03	(\$253.75) CR-1657	Receipt: FLETCHER, Ron	1-6510 Member's Current Accounts
CR-1657-0012	9/ 9/03	(\$260.00) CR-1657	Receipt: WELLS, Tom	1-6510 Member's Current Accounts
CR-1657-0013	9/ 9/03	(\$260.00) CR-1657	Receipt: ZENGEL, George	1-6510 Member's Current Accounts
CR-1657-0014	9/ 9/03	(\$100.00) CR-1657	Burton James	1-1800 Miscellaneous Income
CR-1657-0015	9/ 9/03	(\$125.00) CR-1657	New member Ted Fleener	1-1100 Member Dues
CR-1657-0016	9/ 9/03	(\$80.00) CR-1657	Ted Fleener	1-1110 Admin Charge-New Members
CR-1657-0017	9/ 9/03	(\$50.00) CR-1657	Ted Fleener	1-8300 PHF Clearing
CR-1657-0018	9/ 9/03	(\$2.00) CR-1657	Raffle	1-1400 Raffle
CR-1658-0000	9/15/03	\$3,565.50 CR-1658	Bank Deposit: \$3565.50	1-6110 Checking Account-Cal Fed
CR-1658-0001	9/15/03	(\$3,565.50) CR-1658	Retreat checks	1-1620 Retreat
CR-1667-0000	9/30/03	\$1,628.00 CR-1667	Bank Deposit: \$1628.00	1-6110 Checking Account-Cal Fed
CR-1667-0001	9/30/03	(\$50.00) CR-1667	Receipt: BRINKMAN, Juergen	1-6510 Member's Current Accounts
CR-1667-0002	9/30/03	(\$25.00) CR-1667	Receipt: FARKAS, Art	1-6510 Member's Current Accounts
CR-1667-0003	9/30/03	(\$260.00) CR-1667	Receipt: MERZOIAN, Matt	1-6510 Member's Current Accounts
CR-1667-0004	9/30/03	(\$225.00) CR-1667	Receipt: OGDEN, Thomas	1-6510 Member's Current Accounts
CR-1667-0005	9/30/03	(\$85.00) CR-1667	Receipt: PALMER, Gregg J.	1-6510 Member's Current Accounts
CR-1667-0006	9/30/03	(\$225.00) CR-1667	Receipt: SHIMA, Sam	1-6510 Member's Current Accounts
CR-1667-0007	9/30/03	(\$100.00) CR-1667	Receipt: SCOTT, Skip	1-6510 Member's Current Accounts
CR-1667-0008	9/30/03	(\$125.00) CR-1667	Receipt: SKEWES, John	1-6510 Member's Current Accounts
CR-1667-0009	9/30/03	(\$125.00) CR-1667	Receipt: SKEWES, John	1-6510 Member's Current Accounts
CR-1667-0010	9/30/03	(\$50.00) CR-1667	Receipt: BRISTOL, Scott	1-6510 Member's Current Accounts
CR-1667-0011	9/30/03	(\$100.00) CR-1667	Raffle	1-1400 Raffle
CR-1667-0012	9/30/03	(\$3.00) CR-1667	Raffle	1-1400 Raffle
CR-1667-0013	9/30/03	(\$125.00) CR-1667	Karen MacMillan Dues	1-1100 Member Dues
CR-1667-0014	9/30/03	(\$50.00) CR-1667	Karen MacMillan Paul Harris contribution	1-8300 PHF Clearing
CR-1667-0015	9/30/03	(\$80.00) CR-1667	Karen MacMillan new member admin charge	1-1110 Admin Charge-New Members
		\$0.00		
GJ General Journal				
GJ-1655-00001	9/15/03	\$15.00 GJ-1655	To charge Dave S. and Mike G. for lunch paid by Scott B.	1-6510 Member's Current Accounts
GJ-1655-00002	9/15/03	\$15.00 GJ-1655	To charge Dave S. and Mike G. for lunch paid by Scott B.	1-6510 Member's Current Accounts
GJ-1655-00003	9/15/03	(\$30.00) GJ-1655	To charge Dave S. and Mike G. for lunch paid by Scott B.	1-6510 Member's Current Accounts

Rotary Club of Fig Garden

Club Accounts

Accounting Audit Report: 9/ 1/03 to 9/30/03

Printed 10/13/03

Code	Date	Amount	Ref	Description	GL Account
GJ-1656-00001	9/12/03	\$35.00	GJ-1656	To charge Segal, Wettstead, Merzoian and Townsend for golf at the Retreat.	1-6510 Member's Current Accounts
GJ-1656-00002	9/12/03	\$35.00	GJ-1656	To charge Segal, Wettstead, Merzoian and Townsend for golf at the Retreat.	1-6510 Member's Current Accounts
GJ-1656-00003	9/12/03	\$35.00	GJ-1656	To charge Segal, Wettstead, Merzoian and Townsend for golf at the Retreat.	1-6510 Member's Current Accounts
GJ-1656-00004	9/12/03	\$35.00	GJ-1656	To charge Segal, Wettstead, Merzoian and Townsend for golf at the Retreat.	1-6510 Member's Current Accounts
GJ-1656-00005	9/12/03	(\$140.00)	GJ-1656	To charge Segal, Wettstead, Merzoian and Townsend for golf at the Retreat.	1-1620 Retreat
GJ-1668-00001	9/30/03	\$2.70	GJ-1668	Reverse bank fee	1-6110 Checking Account-Cal Fed
GJ-1668-00002	9/30/03	(\$2.70)	GJ-1668	Reverse bank fee	1-1800 Miscellaneous Income
		\$0.00			

ROTARY CLUB OF FIG GARDEN

FOUNDATION
BOARD OF DIRECTORS

*Regular Meeting: 15 October 2003 --

*Members Present:

*Directors:

August Hioco
Matt Merzoian
Howard Reed
Steve Rontell
Steve Wilson

*Past President:

Eric Fogderude

*Treasurer:

Scott Bristol

*Other(s) Present:

Joetta Winters

*President:

Rod Coburn

*Foundation Treasurer:

Jeff Garza

*President-Elect:

Jamie Franklin

*Secretary:

Doug Cords

The meeting was called to concurrent order with the Regular Board Meeting of the Rotary Club Of Fig Garden by President Rod Coburn in the Boardroom of the Stoughton Davidson Accountancy Corporation at 2530 West Shaw Lane, Suite 101, Fresno, California 93711 at 7:06 a.m.

*TREASURER'S REPORT: (Jeff Garza)

Jeff reviewed the new account, through auspices of David Stepp, at Union Bank; shortly the Washington Mutual account shall be closed.

Jeff reviewed the Income and Expenses, Portfolio Value and the Community Services payments to date. The Foundation is now at its target goal for investments of 70% in equities and 30% in fixed income.

Accounts:

*Unrestricted Funds:	\$120,510.
*Permanent Funds:	<u>152,932.</u>
*Totals:	\$273,442. (rounded)

The Treasurer is presenting extra reports with the new compute programs, which are a great help to the other Board members.

It was MSC to approve the Treasurer's Report as presented.

*ADJOURNMENT: Concurrent With Regular Meeting, President Rod Coburn adjourned the meeting at 8:45 a.m.

*NEXT MEETING: 19 November 2003

Respectfully Submitted By Doug Cords, Ph.D., Foundation Secretary.

FGR Foundation-Net Worth

(Includes unrealized gains)

As of 9/30/2003

10/13/2003

Page 1

Account	8/31/2003 Balance	9/30/2003 Balance
ASSETS		
Cash and Bank Accounts		
UBS Savings-Cash	90,763.91	90,763.91
Union Bank	0.00	20,869.25
WM Checking	26,877.13	8,877.13
TOTAL Cash and Bank Accounts	117,641.04	120,510.29
Investments		
UBS Permanent Fund	153,822.75	152,932.96
UBS Savings	0.00	0.00
TOTAL Investments	153,822.75	152,932.96
TOTAL ASSETS	271,463.79	273,443.25
LIABILITIES		
Other Liabilities		
Paul Harris Receipts Due RI	2,365.00	2,865.00
TOTAL Other Liabilities	2,365.00	2,865.00
TOTAL LIABILITIES	2,365.00	2,865.00
OVERALL TOTAL	269,098.79	270,578.25

Fig Garden Rotary Foundation
7/1/2003 Through 6/30/2004 Using My Budget

10/13/2003

Page 1

Category Description	7/1/2003 Actual	- Budget	6/30/2004 Difference
INCOME			
Auction 2004	0.00	75,000.00	-75,000.00
Clear Channel Donations	11,000.00	20,000.00	-9,000.00
Contributions from Club	0.00	10,000.00	-10,000.00
Earnings from Perm Fund	0.00	400.00	-400.00
Interest Inc	114.88	0.00	114.88
TOTAL INCOME	11,114.88	105,400.00	-94,285.12
EXPENSES			
Administrative Exps	0.00	25.00	25.00
Auction 2005 Expenses	0.00	19,500.00	19,500.00
Bank Charge	130.75	0.00	-130.75
Investment Expenses	315.06	0.00	-315.06
TOTAL Bank Charge	445.81	0.00	-445.81
Community Service	0.00	0.00	0.00
Community Service Donations 2003-2004	13,032.00	55,000.00	41,968.00
TOTAL Community Service	13,032.00	55,000.00	41,968.00
Contributions to PF FGRF	0.00	10,000.00	10,000.00
International Service	0.00	5,000.00	5,000.00
Misc Donations	0.00	500.00	500.00
Polio Plus	0.00	5,250.00	5,250.00
Vocational Service	0.00	5,000.00	5,000.00
Vocational Scholarships	0.00	5,000.00	5,000.00
TOTAL Vocational Service	0.00	10,000.00	10,000.00
TOTAL EXPENSES	13,477.81	105,275.00	91,797.19
OVERALL TOTAL	-2,362.93	125.00	-2,487.93

Portfolio Value

As of 9/30/2003

10/13/2003

Page 1

Security	Shares	Price	est	Cost Basis	Pre-Tax Gain	Balance
CD Discover Bnk 2.50% 11/...	120.000	100.924		12,000.00	110.88	12,110.88
CD Ind Bnk East 2.00% 10/2...	130.000	100.002		12,973.87	26.39	13,000.26
CD Key Bnk 3.10% 11/08/05	130.000	101.117		13,000.00	145.21	13,145.21
CD Pan Am Bnk 3.65% 10/3...	130.000	101.897		12,930.84	315.77	13,246.61
Growth Fund of America	853.606	21.800		18,562.25	46.36	18,608.61
Liberty Acorn	1,083.000	19.440		17,187.25	3,866.27	21,053.52
Pimco Small Cap Value	895.000	22.380		18,095.89	1,934.21	20,030.10
Pimco Value Fund	1,613.000	13.440		18,090.05	3,588.67	21,678.72
Templeton Foreign	2,020.000	9.700		16,727.00	2,867.00	19,594.00
-Cash-				91,228.96	0.00	91,228.96
TOTAL Investments				230,796.11	12,900.76	243,696.87

Fig Garden Rotary Endowment Account

Asset Allocation

US Large Co. Equity	\$ 40,287.33	26.34%
US Med/Sm Co. Equity	\$ 41,083.62	26.86%
Int'l Equity	\$ 19,594.00	12.81%
Int'l Fixed Income	\$ -	0.00%
US Fixed Income	\$ 51,502.96	33.68%
Cash / M.M	\$ 465.05	0.30%
	\$ 152,932.96	100.00%

Account Allocation

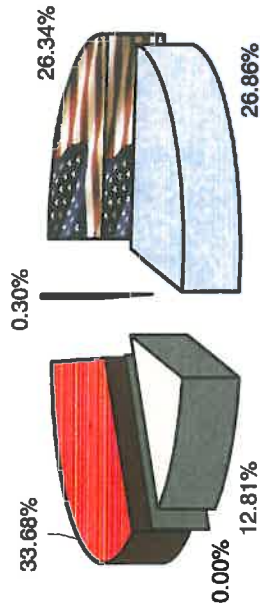

<input checked="" type="checkbox"/> US Large Co. Equity	<input type="checkbox"/> US Med/Sm Co. Equity
<input type="checkbox"/> Int'l Equity	<input type="checkbox"/> Int'l Fixed Income
<input checked="" type="checkbox"/> US Fixed Income	<input type="checkbox"/> Cash / M.M



Paul Sahota - Financial Advisor.

Investment Holdings

	Cost		Value		Percent Gain / loss
	Basis	9/30/2003	Basis	9/30/2003	
<u>US Large Co. Equity:</u>					
Pimco Value Fund	\$ 18,092.69	\$ 21,678.72	\$ 18,092.69	\$ 21,678.72	19.82%
Growth Fund of America	\$ 18,562.25	\$ 18,608.61	\$ 18,562.25	\$ 18,608.61	0.25%
<u>US Med/Sm Co. Equity:</u>					
Liberty Acorn Fund	\$ 17,189.48	\$ 21,053.52	\$ 17,189.48	\$ 21,053.52	22.48%
Pimco Small Cap Value	\$ 18,097.42	\$ 20,030.10	\$ 18,097.42	\$ 20,030.10	10.68%
<u>Int'l Equity</u>					
Templeton Foreign	\$ 16,729.41	\$ 19,594.00	\$ 16,729.41	\$ 19,594.00	17.12%
<u>US & Int'l Fixed Income:</u>					
CD Independent Bank 2% due 10/23/03	\$ 12,973.87	\$ 13,000.26	\$ 12,973.87	\$ 13,000.26	0.20%
CD Discover Bank 2.5% due 11/08/04	\$ 12,000.00	\$ 12,110.88	\$ 12,000.00	\$ 12,110.88	0.92%
CD Key Bank & Trust 3.1% due 11/08/05	\$ 13,000.00	\$ 13,145.21	\$ 13,000.00	\$ 13,145.21	1.12%
CD Pan American Bank 3.65% due 10/30/06	\$ 12,930.84	\$ 13,246.61	\$ 12,930.84	\$ 13,246.61	2.44%
<u>Cash / Money Market:</u>					
Money Market	\$ 465.05	\$ 465.05	\$ 465.05	\$ 465.05	0.00%
TOTAL PORTFOLIO	\$ 140,041.01	\$ 152,932.96	\$ 140,041.01	\$ 152,932.96	9.21%
Cash & Cash Equivalents					
	\$ 465.05	\$ 465.05	\$ 465.05	\$ 465.05	
Total Securities	\$ 140,041.01	\$ 152,932.96	\$ 140,041.01	\$ 152,932.96	

Foundation Account Value \$ 90,801.35

This is not an official Statement.
The information was obtained from sources deemed reliable, but we do not guarantee its accuracy.
Strictly for illustrative purposes only.

FGRF-Community Service Donations YTD

1/1/2003 Through 10/13/2003

10/13/2003

Page 1

Cat/Sub	Date	Account	Num	Description	Memo	Cl	Amount
EXPENSES							
Community Service							
Community Service ...							
	7/18/2...	WM Chec...	628	Fresno Survivors of Suicide	Board Mtg 7/16/03	R	-1,222.00
	7/18/2...	WM Chec...	629	Salvation Army	Board Mtg 7/16/03	R	-550.00
	7/18/2...	WM Chec...	630	Sequoia Council of Boy S...	Board Mtg 7/16/03	R	-1,000.00
	7/18/2...	WM Chec...	631	Criminal Justice Advocates	Board Mtg 7/16/03	R	-1,060.00
	8/20/2...	WM Chec...	632	Housing League of Fresno	Operation School Bell	R	-700.00
	9/17/2...	WM Chec...	634	Big Brothers/Big Sisters	HS Big Mentoring B...		-6,000.00
	9/17/2...	WM Chec...	635	Trauma Intervention Progr...	BofD Mtg 9/17/03		-2,500.00
TOTAL Community ...							-13,032.00
TOTAL Community S...							-13,032.00
TOTAL EXPENSES							-13,032.00
OVERALL TOTAL							-13,032.00

ROTARY CLUB OF FIG GARDEN

BOARD OF DIRECTORS

*Regular Meeting: 19 November 2003 --

*Members Present:

*Directors:

Mike Graves
August Hioco
Matt Merzoian
Jeff Oliver
Howard Reed
Dave Stepp
Steve Wilson

*Foundation Treasurer:

Jeff Garza

*Past-President:

Eric Fogderude

*Secretary:

Doug Cords

*Other(s) Present:

Darryl Booth

*President:

Dr. Rod Coburn

*Treasurer:

Scott Bristol

[Note: Directors Merzoian and Stepp, In Attendance, Were Excused Early]

The meeting was called to order by President Dr. Rod Coburn at 7:01 a.m. in the Boardroom of the Stoughton Davidson Accountancy Corporation at 2530 West Shaw Lane, Suite 101, Fresno, California 93711.

Beginning Note: Director Mike Graves was automatically disqualified from the Board Of Direcots on 15 October, following missing a third meeting; it was MSC to reinstate Mike to his Director's position.

*CONSENT ITEMS:

*Minutes Of The 15 October 2003 Regular Board Meeting
*Attendance For The Month Of October, 2003 = 77%
*Membership As Of 1 November 2003 = 103

It was MSC to approve the Consent Items as presented.

*TREASURER'S REPORT: (Scott Bristol)

The Treasurer reviewed the Key Accounts, as follows:

*Checking Account:	\$18,821.00
*Morgan Stanley:	26,701.00
*Accounts Receivable/Members:	17,479.00
*Note Payable/Playland:	5,000.00
*Totals:	<u>\$68,001.00</u>

There are sufficient funds available to cover all Club costs, as forecast.

*TREASURER'S REPORT, Continued:

Scott reviewed October's Income and Expenses, followed by a presentation of October And Year To Date versus Budget. He also presented Year To Dates for the prior year.

It was MSC to approve the Treasurer's Report as presented.

*SECRETARY'S REPORT: (Doug Cords)

The "District Attendance Report" for August, 2003 was circulated. Fig Garden Rotary continues to achieve some of the highest attendance numbers in our local area.

The Rotary International "Officers Report" was received and is due in Evanston late December; the names and positions will be completed after the Club's Annual Nominating Meeting in early December.

A kind thank you letter from Past President Allen Taylor was circulated, expressing his appreciation for his "Excuse From Attendance Requirements," and sharing his desire to soon return to the Club as an active member.

It was MSC to approve the Classification Committee's re-classification of member Sam Shima to: Gymnastics: Health And Fitness. Secretary to order a replacement Blue Badge for Sam.

It was MSC to approve an "Excuse From Attendance Requirements" for Past President Mary Lou Gunn, who is relocating with Clear Channel Communications to the Pacific Northwest.

All Secretarial materials are ready for the upcoming District Governor's Club Visit on November 21st.

New Member Pipeline:

Keri Donis, sponsored by Dave Holden and Matt Merzoian, will be inducted into the Club on December 5th.

Gene Mollenkamp, sponsored by Rod Coburn and Doug Cords, has completed all initial steps and is to be published in Avenues this coming week. Pending approval, he also will be inducted on December 5th, with Kerri. Gene is a former member of Redmond (Seattle) Rotary Club.

Former member Doug Holton, planning on returning soon, is now at the Classification Committee for proper classification wordsmithing.

New Member Proposal:

BRAD MAJORS

Former Member, Fig Garden Rotary Club
Sponsored By Dave Holden and Tom Wells
County Bank, Branch Manager

Membership Committee has approved
Proposed Classification: Banking: Branch Management

It was MSC to approve the nomination; Secretary to forward to Rotary Information promptly.

*SECRETARY'S REPORT, Continued:

Because of Brad's returning, it was MSC to change Craig DeShields' classification to Banking: Business Banking, of course with his kind permission; Secretary to order new Blue Badge for Craig.

JENNIFER WILLIAMS

Sponsors are Roy Massey and Doug Cords
Guardian Insurance, Assistant Manager
Membership Committee has approved
Proposed Classification: Insurance: Agency Recruitment

It was MSC to approve the nomination; Secretary to forward promptly to Rotary Information.

Craig Gallego, owner of Hodge And Sons, has not been able to attend as the store is closing business; he will be relocating to Stockton, where his wife administers a private hospital. It was MSC to accept Craig's resignation; Secretary to communicate in a "best wishes" letter the Club's regrets to lose him.

Member John Townsend is both now in heavy financial arrears to the Club and as well has major attendance problems. In an effort to both salvage his membership and to hopefully recover the funds expended on John's behalf, the Board agreed to terminate his membership, pending his return in approximately three months, per conversations with the Secretary. John has told both President Coburn and the Secretary of his intent to pay off his financial obligations timely. A letter will be sent with this information to John, asking for prompt and regular good-faith payments. Admissions fees would be waived if John completes the payoff timely and wishes to return to Fig Garden Rotary Club.

*PRESIDENT-ELECT'S REPORT:

Jamie Franklin had a conflict with meetings this morning at Valley Children's Hospital. President Coburn noted that we are still waiting for project information from the Wheelchair Foundation. the Auction Committee Chairs are in full speed ahead with planning.

*PAST-PRESIDENT'S REPORT: (Eric Fogderude)

The club's computer equipment must be moved from Playland/Storyland, where it is now stored, due to Sam Shima's leaving his position there. Several Board Members expressed willingness either today or tomorrow to go to the Park and retrieve the equipment, to be then stored in safety (with insurance) at Sam Shima's new place of business. Eric noted that serial numbers for each piece will be tallied shortly, completing an inventory.

Eric shared that a dinner donated by Mike Reynolds at last year's auction was recently held at their beautiful new home in Shaver Lake; laudits were given. The Central California Blood Center will be holding a blood drive today at Krazan Associates, and Board Members were asked to donate.

Rod Rimmer will be asked for a "Letter Of Request" to co-use computer equipment for other clubs' use, along with scope of utilization and commitment for insurance on the equipment when it is loaned - all is subject to Board approval.

*PRESIDENT'S TIME:

(Dr. Rod Coburn)

President Coburn circulated a "thank you" letter from Crime Stoppers for our recent donation.

The District Governor's "Yellow Brick Road" newsletter was circulated.

Rod thanked Board Member August Hioco for spearheading today's blood drive at Krazan And Associaties.

The President circulated a "proposed new policies" data sheet, for member study, with topics to be discussed at December's Board Meeting.

The District Governor's visitation will be Friday. Each member is to report on goals and activities for this Rotary Year. The President, in keeping with this year's theme, will be presenting "slippers" to the Governor's wife. Members are encouraged to bring books, for the drive the Governor's wife is completing.

*AVENUES OF SERVICE:

*Club Service:

(August Hioco and Steve Wilson)

The Tailgagge event was completed, with success. Extra food will be made available at today's Blood Drive.

The family-focused Holiday Event will be 14 December 2003 from 4:00 to 6:30 at The Met.

Dr. Coburn asked the Board to reflect on more positive ways to get all members actively involved in hands-on projects.

Thought for consideration: will Clear Channel Communications dollars continue to come to the Club (in exchange for support at its events) now that Mary Lou Gunn is relocating? Budget may need to be readjusted.

A discussion followed regarding the total original balance of \$1,500, which was donated by an anonymous Club member; specifics on how to utilize the balance need to be delineated.

*Community Service:

(Jeff Oliver)

Through member Bill Griffith, Wishon Elementary School brought forth a request for the sum of \$500. for literacy and reading/writing materials. It was MSC to approve this funding. Jeff Oliver will confer with member Dave Holden about our "Fig Garden Rotary Club Stickers," which have been used with donations to schools. If none are available, Jeff will order in a supply through Dave.

Centennial Project information will be forthcoming shortly.

It was MSC to approve funding in the amount of \$500. for Candlelighters, which will be used to provide food vouchers for low income families at Central California Children's Hospital cafeteria.

*Vocational Service:

(

A brief discussion ensued regarding Job Shadowing, with thanks to all participants.

*International Service: (Howard Reed and Mike Graves)

The Wheelchair Project is on hold, still waiting for Customs Clearance. Rotary Club Of Fresno member Ed Munger is consulting with President Rod on the issues, as he has hands-on experience with this project type.

Marie Miyasaki, Exchange Student, moves in with her new family on 13 December. A final host family is still needed.

Mike Graves is meeting with Bullard High School's Interact to discuss the Exchange Program for Outbound Students.

*OLD BUSINESS:

Playland Loan: President Coburn will ask Past President Greg Baxter to visit in a future meeting with a report on repayments for the loan of \$5,000.

Club monies to the Club Foundation: Scott Bristol shall make a recommendation of amounts at the December Board meeting. Past President Fogderude inquired if monies from the Club could be used for Community Service donations. The Board could approve monies for specific uses, although traditionally extra dollars have gone directly into the Permanent Fund.

*NEW BUSINESS:

No New Business this meeting.

*ADJOURNMENT: President Coburn adjourned the meeting at 8:25 a.m.

*NEXT MEETING: 17 December 2003.

Respectfully Submitted By Doug Cords, Ph.D., Club Secretary.

Rotary Club of Fig Garden

Club Accounts

Balance sheet for period ending 31 October 03

Printed 11/17/03

ACCUMULATED FUNDS

Club Funds

Balance at beginning of year	\$55,806.20
Excess (Deficit) for period	\$9,996.41
Balance to Date	\$65,802.61

TOTAL FUNDS	\$65,802.61
--------------------	--------------------

Represented by:

ASSETS

Checking Account-Cal Fed	\$18,821.02
Morgan Stanley Dean Witter	\$26,701.90
Member's Current Accounts	\$17,479.69
Note Rec - Playland	\$5,000.00
Total Assets	\$68,002.61

LIABILITIES

Foundation Payable	\$500.00
PHF Clearing	\$200.00
Woodward Park Bench Project	\$1,500.00
Total Liabilities	\$2,200.00

NET ASSETS	\$65,802.61
-------------------	--------------------

Rotary Club of Fig Garden

Club Accounts

Income & Expenditure: Current Month & Year to Date to October 03

Printed 11/17/03

	Current Month	Year to Date
INCOME		
Member Dues	\$125.00	\$11,875.00
Admin Charge-New Members	\$80.00	\$240.00
Fines	(\$50.00)	\$5,068.75
Raffle	\$43.00	\$345.00
Interest	\$35.31	\$35.31
Demotion Party	\$0.00	\$150.00
Retreat	\$0.00	\$3,705.50
Races	\$391.00	\$391.00
Offsite Lunches	\$848.00	\$1,738.00
Miscellaneous Income	\$0.00	\$676.83
Total Income	\$1,472.31	\$24,225.39
EXPENDITURE		
R.I. Dues	\$0.00	\$3,014.85
District Dues	\$0.00	\$2,486.76
Supplies and Postage	\$0.00	\$195.76
Officer Expense	\$295.40	\$295.40
Miscellaneous Expense	\$0.00	\$340.48
Speakers	\$0.00	\$505.44
Demotion Party	\$0.00	\$75.00
Banners, Badges, Pins	\$0.00	\$787.06
Duck Races	\$0.00	\$1,837.00
Retreat	\$0.00	\$4,381.23
Offsite Lunches	\$0.00	\$10.00
Youth Exchange	\$0.00	\$300.00
Total Expenditure	\$295.40	\$14,228.98
Excess (Deficit)	\$1,176.91	\$9,996.41

Rotary Club of Fig Garden

Club Accounts

Income & Expenditure: Current Year vs Previous Year to October 03

Printed 11/17/03

	Month		Year to Date	
	Current Year	Previous Year	Current Year	Previous Year
INCOME				
Member Dues	\$125.00	\$0.00	\$11,875.00	\$13,500.00
Admin Charge-New Members	\$80.00	\$0.00	\$240.00	\$0.00
Fines	(\$50.00)	\$0.00	\$5,068.75	\$5,831.25
Raffle	\$43.00	\$0.00	\$345.00	\$312.00
Interest	\$35.31	\$0.00	\$35.31	\$54.46
Demotion Party	\$0.00	\$0.00	\$150.00	\$0.00
Roger Rockas	\$0.00	\$0.00	\$0.00	\$76.00
Retreat	\$0.00	\$0.00	\$3,705.50	\$0.00
Races	\$391.00	\$1,957.00	\$391.00	\$1,957.00
Offsite Lunches	\$848.00	\$0.00	\$1,738.00	\$0.00
Miscellaneous Income	\$0.00	\$0.00	\$676.83	\$920.00
Paul Harris	\$0.00	\$190.00	\$0.00	\$190.00
Total Income	\$1,472.31	\$2,147.00	\$24,225.39	\$22,840.71
EXPENDITURE				
R.I. Dues	\$0.00	\$0.00	\$3,014.85	\$3,133.75
District Dues	\$0.00	\$0.00	\$2,486.76	\$2,657.42
Supplies and Postage	\$0.00	\$96.33	\$195.76	\$554.44
Computer Expenses and Web Site	\$0.00	\$0.00	\$0.00	\$522.00
Officer Expense	\$295.40	\$3,186.88	\$295.40	\$3,186.88
Terminated Members	\$0.00	\$0.00	\$0.00	\$250.00
Miscellaneous Expense	\$0.00	\$685.00	\$340.48	\$1,212.50
Bank Charges	\$0.00	\$0.00	\$0.00	\$4.00
Lunch-Tornino's	\$0.00	\$0.00	\$0.00	\$333.50
Speakers	\$0.00	\$0.00	\$505.44	\$0.00
Demotion Party	\$0.00	\$0.00	\$75.00	\$512.52
Banners, Badges, Pins	\$0.00	\$0.00	\$787.06	\$384.43
Hospitality and Fellowship	\$0.00	\$0.00	\$0.00	\$1,175.46
Duck Races	\$0.00	\$0.00	\$1,837.00	\$0.00
Retreat	\$0.00	\$4,116.55	\$4,381.23	\$4,116.55
The Races	\$0.00	\$1,934.34	\$0.00	\$1,934.34
Mystery Dinner	\$0.00	\$0.00	\$0.00	\$34.62
Offsite Lunches	\$0.00	\$0.00	\$10.00	\$0.00
Camp Royal	\$0.00	\$0.00	\$0.00	(\$58.38)
Youth Exchange	\$0.00	\$0.00	\$300.00	\$0.00
Total Expenditure	\$295.40	\$10,019.10	\$14,228.98	\$19,954.03
Excess (Deficit)	\$1,176.91	(\$7,872.10)	\$9,996.41	\$2,886.68

ROTARY CLUB OF FIG GARDEN

FOUNDATION
BOARD OF DIRECTORS

*Regular Meeting: 19 November 2003 --

*Members Present:

*Directors:

Mike Graves
August Hioco
Matt Merzoian
Jeff Oliver
Howard Reed
Dave Stepp
Steve Wilson

*Foundation Treasurer:

Jeff Garza

*Other(s) Present:

Darryl Booth

*Past-President:

Eric Fogderude

*Secretary:

Doug Cords

*President:

Dr. Rod Coburn

*Treasurer:

Scott Bristol

The meeting was called to concurrent order with the Regular Board Meeting of the Rotary Club Of Fig Garden by President Rod Coburn in the Boardroom of the Stoughton Davidson Accountancy Corporation at 2530 West Shaw Lane, Suite 101, Fresno, California 93711 at 7:01 a.m.

*TREASURER'S REPORT:

(Jeff Garza)

Jeff reviewed initially last month's Income and Expenses Year To Date versus Budget. He then reviewed Portfolio Values, reminding the Board that the investment goals are 70% equities and 30% income.

Accounts:

*Unrestricted Funds:	\$116,748.00
*Permanent Funds:	<u>159,498.00</u>
*Totals:	\$276,246.00

The system conversion to Quickbooks is in process. All bank accounts have been reconciled.

The Board requested for information on "benchmark" numbers and performance of investments from the date of acquisition; this shall be possible with Quickbooks.

The Club's Investment Committee met the week prior to this meeting. It reinvested a maturing C. D., to keep within the guidelines so noted and to effectively ladder Certificates Of Deposit. The group will again convene in February.

Jeff had met with former Foundation Treasurer Tripp Pound, to go over issues regarding the organization's tax filings, which Tripp will assist this year.

It was MSC to approve the Treasurer's Report as presented.

*ADJOURNMENT: Concurrent With Regular Meeting, President Rod Coburn adjourned the meeting at 8:25 a.m.

*NEXT MEETING: 17 December 2003

Respectfully Submitted By Doug Cords, Ph.D., Foundation Secretary.

FGR Foundation-Net Worth

(Includes unrealized gains)

As of 10/31/2003

1/15/2003

Page 1

Account	9/30/2003 Balance	10/31/2003 Balance
ASSETS		
Cash and Bank Accounts		
UBS Savings-Cash	90,763.91	90,842.02
Union Bank	20,869.25	25,021.25
WM Checking	8,881.86	884.63
TOTAL Cash and Bank Accounts	<u>120,515.02</u>	<u>116,747.90</u>
Investments		
UBS Permanent Fund	152,932.96	159,498.40
UBS Savings	0.00	0.00
TOTAL Investments	<u>152,932.96</u>	<u>159,498.40</u>
TOTAL ASSETS	<u>273,447.98</u>	<u>276,246.30</u>
LIABILITIES		
Other Liabilities		
Paul Harris Receipts Due RI	2,865.00	3,245.00
TOTAL Other Liabilities	<u>2,865.00</u>	<u>3,245.00</u>
TOTAL LIABILITIES	<u>2,865.00</u>	<u>3,245.00</u>
OVERALL TOTAL	<u>270,582.98</u>	<u>273,001.30</u>

FGRF Fiscal Year Budget Report
7/1/2003 Through 6/30/2004 Using My Budget

11/17/2003

Page 1

Category Description	7/1/2003 Actual	- Budget	6/30/2004 Difference
INCOME			
Auction 2004	0.00	75,000.00	-75,000.00
Clear Channel Donations	11,000.00	20,000.00	-9,000.00
Contributions from Club	0.00	10,000.00	-10,000.00
Earnings from Perm Fund	0.00	400.00	-400.00
Interest Inc	163.05	0.00	163.05
TOTAL INCOME	11,163.05	105,400.00	-94,236.95
EXPENSES			
Administrative Exps	0.00	25.00	25.00
Auction 2005 Expenses	0.00	19,500.00	19,500.00
Bank Charge	158.75	0.00	-158.75
Investment Expenses	630.12	0.00	-630.12
TOTAL Bank Charge	788.87	0.00	-788.87
Community Service	0.00	0.00	0.00
Community Service Donations 2003-2004	17,232.00	55,000.00	37,768.00
TOTAL Community Service	17,232.00	55,000.00	37,768.00
Contributions to PF FGRF	0.00	10,000.00	10,000.00
International Service	0.00	5,000.00	5,000.00
Misc Donations	0.00	500.00	500.00
Polio Plus	0.00	5,250.00	5,250.00
Vocational Service	0.00	5,000.00	5,000.00
Vocational Scholarships	0.00	5,000.00	5,000.00
TOTAL Vocational Service	0.00	10,000.00	10,000.00
TOTAL EXPENSES	18,020.87	105,275.00	87,254.13
OVERALL TOTAL	-6,857.82	125.00	-6,982.82

Portfolio Value

As of 10/31/2003

11/17/2003

Page 1

Security	Shares	Price	est	Cost Basis	Pre-Tax Gain	Balance
CD Discover Bnk 2.50% 11/...	120.000	100.753		12,000.00	90.36	12,090.36
CD Key Bnk 3.10% 11/08/05	130.000	100.976		13,000.00	126.88	13,126.88
CD Pan Am Bnk 3.65% 10/3...	130.000	101.706		12,930.84	290.94	13,221.78
Columbia Acorn	1,083.000	21.020		17,187.25	5,577.41	22,764.66
Growth Fund of America	853.606	23.170		18,562.25	1,215.80	19,778.05
Pimco Small Cap Value	895.000	23.710		18,095.89	3,124.56	21,220.45
Pimco Value Fund	1,613.000	14.290		18,090.05	4,959.72	23,049.77
Templeton Foreign	2,020.000	10.030		16,727.00	3,533.60	20,260.60
-Cash-				104,827.87	0.00	104,827.87
TOTAL Investments				231,421.15	18,919.27	250,340.42

FGRF-Community Service Donations YTD

7/1/2003 Through 11/17/2003

11/17/2003

Cat/Sub	Date	Account	Num	Description	Memo	Cl	Amount
EXPENSES							
Community Service							
Community Service ...							
	10/24/...	Union Bank	1001	Crime Stoppers			-1,200.00
	10/24/...	Union Bank	1002	Fresno Co. Office of Educ...	Raymacher School		-3,000.00
	11/4/2...	Union Bank	1003	Fresno Police Chiefs Foun...	Bomb Dog		-500.00
	11/4/2...	Union Bank	1004	Al Trujillo	Christmas Baskets		-2,000.00
	7/18/2...	WM Chec...	628	Fresno Survivors of Suicide	Board Mtg 7/16/03	R	-1,222.00
	7/18/2...	WM Chec...	629	Salvation Army	Board Mtg 7/16/03	R	-550.00
	7/18/2...	WM Chec...	630	Sequoia Council of Boy S...	Board Mtg 7/16/03	R	-1,000.00
	7/18/2...	WM Chec...	631	Criminal Justice Advocates	Board Mtg 7/16/03	R	-1,060.00
	8/20/2...	WM Chec...	632	Housing League of Fresno	Operation School Bell	R	-700.00
	9/17/2...	WM Chec...	634	Big Brothers/Big Sisters	HS Big Mentoring B...	R	-6,000.00
	9/17/2...	WM Chec...	635	Trauma Intervention Progr...	BofD Mtg 9/17/03	R	-2,500.00
							-19,732.00
							-19,732.00
TOTAL Community ...							-19,732.00
TOTAL Community S...							-19,732.00
TOTAL EXPENSES							-19,732.00
OVERALL TOTAL							-19,732.00

Fig Garden Rotary Endowment Account

Asset Allocation

US Large Co. Equity	\$ 42,827.82	26.85%
US Med/Sm Co. Equity	\$ 43,985.11	27.58%
Int'l Equity	\$ 20,260.60	12.70%
Int'l Fixed Income	\$ -	0.00%
US Fixed Income	\$ 38,439.02	24.10%
Cash / M.M	\$ 13,985.85	8.77%
	\$ 159,498.40	100.00%

Account Allocation

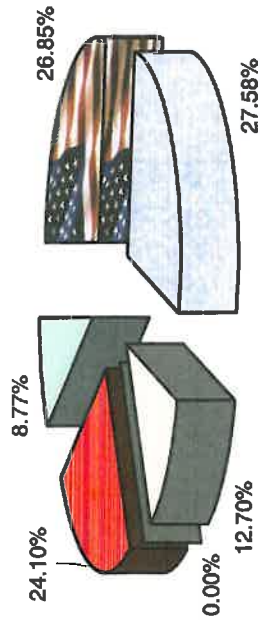

- US Large Co. Equity
- Int'l Equity
- US Fixed Income
- US Med/Sm Co. Equity
- Int'l Fixed Income
- Cash / M.M



Paul Sahota - Financial Advisor.

Investment Holdings

	Cost		Value	Percent Gain / loss
	Basis	10/31/2003	10/31/2003	
<u>US Large Co. Equity:</u>				
Pimco Value Fund	\$ 18,092.69	\$ 23,049.77	27.40%	
Growth Fund of America	\$ 18,562.25	\$ 19,778.05	6.55%	
<u>US Med/Sm Co. Equity:</u>				
Columbia Acorn Fund *	\$ 17,189.48	\$ 22,764.66	32.43%	
Pimco Small Cap Value	\$ 18,097.42	\$ 21,220.45	17.26%	
<u>Int'l Equity</u>				
Templeton Foreign	\$ 16,729.41	\$ 20,260.60	21.11%	
<u>US & Int'l Fixed Income:</u>				
CD Discover Bank 2.5% due 11/08/04	\$ 12,000.00	\$ 12,090.36	0.75%	
CD Key Bank & Trust 3.1% due 11/08/05	\$ 13,000.00	\$ 13,126.88	0.98%	
CD Pan American Bank 3.65% due 10/30/06	\$ 12,930.84	\$ 13,221.78	2.25%	
<u>Cash / Money Market:</u>				
Money Market	\$ 13,985.85	\$ 13,985.85	0.00%	
TOTAL PORTFOLIO	\$ 140,587.94	\$ 159,498.40	13.45%	
Cash & Cash Equivalents				
	\$ 13,985.85	\$ 13,985.85		
Total Securities				
	\$ 140,041.01	\$ 159,498.40		
Foundation Account Value				
	\$	\$ 90,842.02		

* Fund Name Change

This is not an official Statement.
The information was obtained from sources deemed reliable, but we do not guarantee its accuracy.
Strictly for illustrative purposes only.

ROTARY CLUB OF FIG GARDEN

BOARD OF DIRECTORS

*SPECIAL MEETING - 21 November 2003 --
District Governor's Official Visit -

The Meeting Was Duly Noticed Via Fax On 14 November 2003, Per By-Laws.

Members Present:

August Hioco
Howard Reed
Steve Wilson
Mike Graves
Steve Rontell
Jamie Franklin
Doug Cords
Rod Coburn
Richard Saroyan
Dave Stepp
Eric Fogderude

COGS Present:

Karen McMillan
Dennis Archer
Roy Massey

Visiting District Officials:

Rod Belton, District Governor
Ted Marsella, Assistant District Governor
Scott Leonard, Areas Representative

This meeting was called to order at TorNino's Banquet Hall in Fresno, California at 10:32 a.m. by President Rod Coburn.

Rod expressed sincere appreciation to the District Leaders and made formal introductions of each individual.

Steve Rontell reported on Community Service Projects and Fundings; he focused upon our own goal of many "hands-on" projects; the Centennial Project was reviewed. The Governor suggested a Longitudinal Study of Benefits Garnered By Students Blessed Somehow Through A FGR Program, then asking those to come address the Club. President Coburn covered the Woodward Park Bench Project.

Eric Fogderude noted his appreciation of the P.E.T.S. project and shared that his sons are active Interact members at Bullard High School.

August Hioco reported on the Club Service calendar and events, focusing also upon special COG-related meetings and special programs and events.

Dave Stepp reported on Vocational Service Programs, including scholarships, Job Shadowing, Camp Royal, members' professional employment site visits and vocational talks. Governor Rod suggested it might be worthwhile to ask COGS to do a vocational talk as part of their introductory steps to Fig Garden Rotary Club.

Howard Reed reported on International Service, sharing our main focus currently is the providing of 240 wheelchairs for Quito, Ecuador citizens; also reviewed was the Group Study Exchange, Student Exchange Programs and a proposed project in Mexico. Governor Rod encouraged a "twin city" club program. Fig Garden Rotary, per President-Elect Jamie Franklin, shall next year participate in the Student/Scholarship Exchange Program, as is being done this year. Governor Rod shared that the District has available Individual Grants, only by application, for members to travel to research potential projects and partners.

President-Elect Jamie Franklin shared a personal, life goal in which he

desires to role model for his family to have a special, caring heart for the world. Serving as President next year is a privilege and incredible responsibility, shared Jamie, and he is truly looking forward to this chapter of his life. It can also serve as a prime example to family and others to Lend A Hand.

President Coburn reviewed the Rotary Foundation, including Paul Harris Fellows, Sustaining Members, matching funds programs and our Club's overall supportive philosophy towards the Foundation. Governor Rod noted that the sum of \$227,695 in total giving from our Club is now on record with the Foundation; there are 9,400 Foundation "Recognition Points" available for our Club's utilization, subject to some restrictions from RI.

The meeting was adjourned at 11:15 a.m.

Respectfully Submitted By Doug Cords, Ph.D., Club Secretary.

ROTARY CLUB OF FIG GARDEN

BOARD OF DIRECTORS

*Regular Meeting -- 17 December 2003:

*Members Present:

Mike Graves
August Hioco
Matt Merzoian
Jeff Oliver
Steve Rontell
David Stepp
Steve Wilson

*President:

Dr. Rod Coburn

*Treasurer:

Scott Bristol

*Foundation Treasurer:

Jeff Garza

*Past President:

Eric Fogderude

*President-Elect:

Jamie Franklin

*Secretary:

Doug Cords

*Others Present:

Darryl Booth
Joe Farmer

The meeting was called to order by President Dr. Rod Coburn at 7:00 a.m. in the Boardroom of the Stoughton Davidson Accountancy Corporation at 2530 West Shaw Lane, Suite 101, Fresno, California 93711.

*CONSENT ITEMS:

*Attendance For Month Of November, 2003	=	81%
*Membership As Of 1 December 2003:	=	102

It was MSC to approve the Consent Items as presented.

*APPROVAL OF MINUTES:

*Minutes Of Regular Board Meeting Of 19 November 2003
*Minutes Of Special Board Meeting Of 21 November 2003

It was MSC to approve the Minutes as presented.

*TREASURER'S REPORT:

(Scott Bristol)

Scott reviewed Income and Expenditures for the Current Month, Versus Year To Date.

Accounts:

<u>Assets:</u>	*Checking:	\$20,159.00
	*Morgan Stanley:	26,701.00
	*Members' Accounts:	14,183.00
	*Playland Note:	5,000.00
	*Totals:	<u>\$66,043.00</u>

<u>Liabilities:</u>	*Foundation Payable:	500.00
	*Paul Harris Fellws.	200.00
	*W.P. Banches:	1,500.00
	Totals:	<u>\$ 2,200.00</u>

*TREASURER'S REPORT, Continued:

Scott reviewed the Balance Of Budget Year To Date.

It was MSC to approve the Treasurer's Report as presented.

It was MSC to transfer the sum of \$5,000.00 from Club Funds to the Foundation.

*SECRETARY'S REPORT: (Doug Cords)

Official Notification to Rotary International, due 31 December, was sent regarding:

- *Meeting Day And Time and Location
- *President and Secretary
- *Contact Information (Secretary's Phone/Address)

The Secretary circulated the latest District Attendance Report, for September, 2003.

Special thanks were given to Jeff Garza for completing the Minutes as the Secretary has to exit early, and to President Coburn for hand-delivering the drafts.

For the record, approved at the Club's Official Annual Meeting of 5 December, 2003:

- | | |
|---------------------------------|----------------|
| *President-Elect/Elect: | Phil Setrakian |
| *Club Treasurer: | Scott Bristol |
| *Foundation Treasurer: | Jeff Garza |
| *Club and Foundation Secretary: | Doug Cords |
| *Directors: | Deborah Coe |
| | Bob Gunning |
| | Lucy Ollivier |
| | Kurt Zumwalt |

An extensive discussion ensued regarding club policy and procedures with regard to members' past due accounts. It was suggested that perhaps an "Assistant To The Treasurer" post might be created and this individual be charged with responsibility in this area. It also is desirable to formalize specific Club Policy with regard to members' receivables.

It was MSC to develop an Ad Hoc Committee to focus on collections, procedures and club proposed policy, Dr. Coburn to appoint delegates.

Member Bob Abrams is out of the area on work. He was unable to meet the Board deadline for providing a written application for "Excuse From Attendance Requirements." After verbally hearing the situation, it was MSC to approve a 90-day request, pending written application, for club files.

Again because of scheduling, former member Don Milligan's nomination for membership was considered without formal paperwork. Sponsors are Matt Merzoian and Lucy Ollivier. It was MSC to approve the nomination, with the Secretary charged with completion timely of all required paperwork.

*SECRETARY'S REPORT, Continued:

The resignation letter of 22-year member Tom Isaac was circulated. Tom has had attendance difficulties for at least two-plus years and found it necessary to leave the Club. Secretary phoned and wrote, encouraging our valued member to contact Fig Garden Rotary when his schedule would allow a return to active membership.

Membership Report:

*Kerri Donis: sponsored by Dave Holden and Matt Merzoian, inducted into Fig Garden Rotary on 5 December 2003

*Gene Mollenkamp: both are ready to be inducted into Fig Garden Rotary,

* Brad Majors: pending receipt of initial funds

*Chet Leiker: former member whose nomination has been put "on hold," as he unfortunately has lost his employment position; Club Secretary and others are attempting to help Chet.

*Jennifer Williams: ready for induction.

It is time for a "Member Roster" to be printed and circulated; President Rod noted this is currently underway.

We have an "Ambassadorial Scholar" attending California State University, Fresno. From Tokyo, Japan, Mirai Hamamoto is studying graduate-level Counseling. District Governor Rod Belton just learned through RI of her presence; he informed Assistant District Governor Ted Marsella; each tried to contact Ms. Hamamoto, with zero results. She, as an Ambassadorial Scholar, is charged with notifying the local District of her whereabouts, which was not done. Secretary has located "unofficially" an e-mail address for her through Fresno State, but she has not responded to a request for a phone contact.

*PRESIDENT-ELECT'S REPORT: (Jamie Franklin)

Plans for the 27 March 2004 Annual Auction are well underway, under the capable guidance of unit co-chairs David Bonnar, Greg Baxter and Doug Brinkley. Jim Rodgers will serve as Auctioneer and plans for the Live Auction are now under review.

Jamie noted that, perhaps as Holiday presents, Board members and families might study the World Vision Catalogue. There is a water project in the country of Haiti whereby Rotary International matching grants are available.

*PAST PRESIDENT'S REPORT: (Eric Fogderude)

Eric circulated the up-to-date listing of Fig Garden Rotary computer inventory. All equipment (except that at Rod Rimmer's residence) is now stored in secure, insured warehouse space at Sam Shima's business. Member Joe Farmer shared a hardware update.

Community Hospitals Of Central California donated computer equipment to Fig Garden Rotary Club, courtesy of member David Bonnar. Especial thanks are to be shared with each, via Club Secretary.

*PAST PRESIDENT'S REPORT, Continued:

The next step is to review all equipment and make recommendations for best utilization processes.

*PRESIDENT'S REPORT: (Dr. Rod Coburn)

Rod noted especial thanks to the members who spearheaded the wonderful Holiday Party at the Met, including Steve Wilson, August Hioco and Tom Anderson.

Regarding the year-long blood drive, President Rod will acknowledge donors, as appropriate, being especially mindful of legislation which protects donor information. There will be no "public notification" of all club donors. Rod encouraged all to donate blood. Tom Anderson is this year's "point/pint person" for the blood program.

On 13 February 2004, Rotary International Jonathan B. Mujiyagbe will speak in San Jose. Avenues shall print this notification shortly, inviting members to hear the International President. Rod circulated the district's house organ "The Yellow Brick Road," for December.

On 24 February 2004, the "Club Program Report Assembly" will be held. All current and next year's Board members are encouraged to attend and participate.

Rod circulated a thank you letter from District Governor Rod Belton, for his recent visit to the club.

The Board affirmed that the Club shall be dark the day following New Year, 2 January 2004.

A Rotaract Club is being reconstituted at California State University, Fresno.

*AVENUES OF SERVICE:

*Club Service: (August Hioco and Steve Wilson)

Mike Gerardi has completed all COG responsibilities and will be awarded his Blue Badge shortly.

The Directors are endeavoring to obtain a block of tickets for an upcoming basketball game at the Save Mart Center.

14 February, Valentine's Day, will have a show and dinner at Roger Rocka's.

*Community Service: (Steve Rontell and Jeff Oliver)

Through Past President John Skewes, it was MSC to approve the sum of \$2,500. for Break The Barriers, to complete purchase of weight equipment. An emblem near the equipment shall recognize Fig Garden Rotary Club. This funding is added to last year's \$2,500., for a total \$5,000. purchase of weights. Last year's request was for mats; the organization, however, has received the Community Service's approval to

*Community Service, continued:

use those funds for the weight equipment.

The Committee proactively sought opportunities to contribute to benefit the elderly community. It was MSC to authorize an expenditure of up to \$2,500. for furniture, DVD/VCR/TV for Veterans' Hospital Clinics. Bill Robinson and Daniel Bonyhadi will supervise and are to seek an "in kind donation" from any supplier(s). There shall be appropriate Fig Garden Rotary plaque(s) attached to any purchase.

President Rod again reiterated his goal and desire to seek out additional "hands-on" project.

Steve Rontell distributed a schedule of donations to date.

Discussion focused on this year's budget in light of Past President Mary Lou Gunn's soon-to-be departure from the Club. We to date have received \$11,000. from the \$20,000. budgeted from the forecast for the year, donations through Clear Channel Communications. Rod and Steve will meet to decide strategy.

The Woodward Park benches are underway, with Jeff in contact with the City Of Fresno regarding site selection.

Last year, \$1,500. was anonymously contributed; it is OK to allocate remaining funds for someone else for a park bench (Skewes).

*Vocational Service: (Dave Stepp and Matt Merzoian)

The Interact Clubs at Bullard and San Joaquin Memorial High Schools have been advised on and invited to participate in the Holiday Gift Basket program.

*International Service: (Mike Graves)

A publicity push will ensue to encourage members who may wish to travel personally to Quito, Ecuador for the Wheelchair Project.

*OLD BUSINESS:

No report this month on the Playland/Storyland debt of \$5,000. Storyland is now refinancing existing bank debt; KSEE Television is coordinating the capital campaign. Things are getting better, but the combined Parks are still "cash poor." Storyland has cash now, but wishes to retain for emergency use. A discussion ensued with the recommendation that the topic be revisited in March, with the possibility of converting the debt to a donation.

Discussion is held next month on Proposed Fig Garden Rotary Club Policies.

*NEW BUSINESS:

No New Business this month.

*ADJOURNMENT: President Dr. Rod Coburn adjourned the meeting at 8:46
a.m.

*NEXT MEETING: 21 January 2004

With Great Input/Assistance From Associate Scribe Jeff Garza, Respectfully
Submitted By Doug Cords, Ph.D., Club Secretary.

Rotary Club of Fig Garden

Club Accounts

Income & Expenditure: Balance of Budget to November 03

(\$28,000.00)

Printed 12/16/03

	Year to Date	Annual Budget	Balance
INCOME			
Member Dues	\$11,875.00	\$28,000.00	\$16,125.00
Admin Charge-New Members	\$240.00	\$1,200.00	\$960.00
Fines	\$5,068.75	\$20,000.00	\$14,931.25
Raffle	\$450.00	\$1,200.00	\$750.00
Interest	\$35.31	\$600.00	\$564.69
Demotion Party	\$150.00	\$5,000.00	\$4,850.00
Retreat	\$3,705.50	\$3,800.00	\$94.50
Races	\$391.00	\$0.00	(\$391.00)
Tailgate	\$636.00	\$720.00	\$84.00
Offsite Lunches	\$1,738.00	\$1,800.00	\$62.00
Christmas Party	\$0.00	\$3,000.00	\$3,000.00
Miscellaneous Income	\$706.83	\$600.00	(\$106.83)
Total Income	\$24,996.39	\$65,920.00	\$40,923.61
EXPENDITURE			
R.I. Dues	\$3,038.85	\$5,800.00	\$2,761.15
District Dues	\$2,521.76	\$5,800.00	\$3,278.24
Supplies and Postage	\$195.76	\$1,800.00	\$1,604.24
Computer Expenses and Web Site	\$0.00	\$360.00	\$360.00
Officer Expense	\$295.40	\$4,000.00	\$3,704.60
Terminated Members	\$0.00	\$1,600.00	\$1,600.00
Miscellaneous Expense	\$552.80	\$1,800.00	\$1,247.20
Bank Charges	\$0.00	\$180.00	\$180.00
Dist Conf and Assembly	\$0.00	\$500.00	\$500.00
Lunch-Tornino's	\$1,451.50	\$1,800.00	\$348.50
FGR Foundation	\$0.00	\$5,000.00	\$5,000.00
Programs	\$91.58	\$600.00	\$508.42
Speakers	\$505.44	\$900.00	\$394.56
Demotion Party	\$75.00	\$5,000.00	\$4,925.00
Bulletin	\$0.00	\$300.00	\$300.00
Banners, Badges, Pins	\$787.06	\$600.00	(\$187.06)
Hospitality and Fellowship	\$0.00	\$3,900.00	\$3,900.00
Blue Book	\$0.00	\$900.00	\$900.00
Rotary Information	\$35.50	\$300.00	\$264.50
Membership	\$0.00	\$600.00	\$600.00
Duck Races	\$1,837.00	\$0.00	(\$1,837.00)
Retreat	\$4,381.23	\$6,000.00	\$1,618.77
Field Trips	\$366.78	\$1,200.00	\$833.22
Tailgate	\$0.00	\$800.00	\$800.00
Offsite Lunches	\$22.00	\$1,800.00	\$1,778.00
Christmas Party	\$0.00	\$3,500.00	\$3,500.00
Valentines Day	\$0.00	\$120.00	\$120.00
Auction	\$0.00	\$900.00	\$900.00
Camp Royal	\$200.00	\$900.00	\$700.00
Christmas Food Basket	\$0.00	\$2,000.00	\$2,000.00
Community Projects	\$0.00	\$1,500.00	\$1,500.00
Bullard Interact	\$0.00	\$300.00	\$300.00
SJM Interact	\$0.00	\$300.00	\$300.00
Youth Exchange	\$600.00	\$300.00	(\$300.00)
Paul Harris	\$0.00	\$1,500.00	\$1,500.00
Group Study Exchange	\$0.00	\$500.00	\$500.00
Total Expenditure	\$16,957.66	\$63,360.00	\$46,402.34

Rotary Club of Fig Garden

Club Accounts

Income & Expenditure: Balance of Budget to November 03

\$500.00

Printed 12/16/03

	Year to Date	Annual Budget	Balance
Excess (Deficit)	\$41,954.05	(\$2,560.00)	\$87,325.95

↑
Error

\$ + 2,560.00

Rotary Club of Fig Garden

Club Accounts

Balance sheet for period ending 30 November 03

Printed 12/16/03

ACCUMULATED FUNDS

Club Funds

Balance at beginning of year	\$55,806.20
Excess (Deficit) for period	\$8,038.73
Balance to Date	\$63,844.93

TOTAL FUNDS	\$63,844.93
--------------------	--------------------

Represented by:

ASSETS

Checking Account-Citibank	\$20,159.84
Morgan Stanley Dean Witter	\$26,701.90
Member's Current Accounts	\$14,183.19
Note Rec - Playland	\$5,000.00
Total Assets	\$66,044.93

LIABILITIES

Foundation Payable	\$500.00
PHF Clearing	\$200.00
Woodward Park Bench Project	\$1,500.00
Total Liabilities	\$2,200.00

NET ASSETS	\$63,844.93
-------------------	--------------------

Rotary Club of Fig Garden

Club Accounts

Income & Expenditure: Current Month & Year to Date to November 03

Printed 12/16/03

	Current Month	Year to Date
INCOME		
Member Dues	\$0.00	\$11,875.00
Admin Charge-New Members	\$0.00	\$240.00
Fines	\$0.00	\$5,068.75
Raffle	\$105.00	\$450.00
Interest	\$0.00	\$35.31
Demotion Party	\$0.00	\$150.00
Retreat	\$0.00	\$3,705.50
Races	\$0.00	\$391.00
Tailgate	\$636.00	\$636.00
Offsite Lunches	\$0.00	\$1,738.00
Miscellaneous Income	\$30.00	\$706.83
Total Income	\$771.00	\$24,996.39
EXPENDITURE		
R.I. Dues	\$24.00	\$3,038.85
District Dues	\$35.00	\$2,521.76
Supplies and Postage	\$0.00	\$195.76
Officer Expense	\$0.00	\$295.40
Miscellaneous Expense	\$212.32	\$552.80
Lunch-Tornino's	\$1,451.50	\$1,451.50
Programs	\$91.58	\$91.58
Speakers	\$0.00	\$505.44
Demotion Party	\$0.00	\$75.00
Banners, Badges, Pins	\$0.00	\$787.06
Rotary Information	\$35.50	\$35.50
Duck Races	\$0.00	\$1,837.00
Retreat	\$0.00	\$4,381.23
Field Trips	\$366.78	\$366.78
Offsite Lunches	\$12.00	\$22.00
Camp Royal	\$200.00	\$200.00
Youth Exchange	\$300.00	\$600.00
Total Expenditure	\$2,728.68	\$16,957.66
Excess (Deficit)	(\$1,957.68)	\$8,038.73

Rotary Club of Fig Garden

Club Accounts

Income & Expenditure: Current Year vs Previous Year to November 03

Printed 12/16/03

	Month		Year to Date	
	Current Year	Previous Year	Current Year	Previous Year
INCOME				
Member Dues	\$0.00	\$250.00	\$11,875.00	\$13,750.00
Admin Charge-New Members	\$0.00	\$160.00	\$240.00	\$160.00
Fines	\$0.00	\$0.00	\$5,068.75	\$5,831.25
Raffle	\$105.00	\$307.00	\$450.00	\$619.00
Interest	\$0.00	\$0.00	\$35.31	\$54.46
Demotion Party	\$0.00	\$0.00	\$150.00	\$0.00
Roger Rockas	\$0.00	\$0.00	\$0.00	\$76.00
Retreat	\$0.00	\$3,711.00	\$3,705.50	\$3,711.00
Races	\$0.00	\$0.00	\$391.00	\$1,957.00
Tailgate	\$636.00	\$520.00	\$636.00	\$520.00
Offsite Lunches	\$0.00	\$0.00	\$1,738.00	\$0.00
Auction	\$0.00	\$100.00	\$0.00	\$100.00
Miscellaneous Income	\$30.00	\$59.04	\$706.83	\$979.04
Paul Harris	\$0.00	\$0.00	\$0.00	\$190.00
Total Income	\$771.00	\$5,107.04	\$24,996.39	\$27,947.75
EXPENDITURE				
R.I. Dues	\$24.00	\$0.00	\$3,038.85	\$3,133.75
District Dues	\$35.00	\$0.00	\$2,521.76	\$2,657.42
Supplies and Postage	\$0.00	\$319.29	\$195.76	\$873.73
Computer Expenses and Web Site	\$0.00	\$0.00	\$0.00	\$522.00
Officer Expense	\$0.00	\$0.00	\$295.40	\$3,186.88
Terminated Members	\$0.00	\$0.00	\$0.00	\$250.00
Miscellaneous Expense	\$212.32	\$359.50	\$552.80	\$1,572.00
Bank Charges	\$0.00	\$3.72	\$0.00	\$7.72
Lunch-Tornino's	\$1,451.50	\$145.00	\$1,451.50	\$478.50
Programs	\$91.58	\$0.00	\$91.58	\$0.00
Speakers	\$0.00	\$0.00	\$505.44	\$0.00
Demotion Party	\$0.00	\$0.00	\$75.00	\$512.52
Banners, Badges, Pins	\$0.00	\$0.00	\$787.06	\$384.43
Hospitality and Fellowship	\$0.00	\$0.00	\$0.00	\$1,175.46
Rotary Information	\$35.50	\$0.00	\$35.50	\$0.00
Duck Races	\$0.00	\$0.00	\$1,837.00	\$0.00
Retreat	\$0.00	\$388.23	\$4,381.23	\$4,504.78
The Races	\$0.00	\$0.00	\$0.00	\$1,934.34
Mystery Dinner	\$0.00	\$0.00	\$0.00	\$34.62
Field Trips	\$366.78	\$0.00	\$366.78	\$0.00
Offsite Lunches	\$12.00	\$0.00	\$22.00	\$0.00
Camp Royal	\$200.00	\$0.00	\$200.00	(\$58.38)
Youth Exchange	\$300.00	\$0.00	\$600.00	\$0.00
Total Expenditure	\$2,728.68	\$1,215.74	\$16,957.66	\$21,169.77
Excess (Deficit)	(\$1,957.68)	\$3,891.30	\$8,038.73	\$6,777.98

Rotary Club of Fig Garden

Club Accounts

Income & Expenditure: Comparison to Budget to November 03

Printed 12/16/03

	Current Month	Year to Date	Budget to Date	Variance
INCOME				
Member Dues	\$0.00	\$11,875.00	\$14,000.00	(\$2,125.00)
Admin Charge-New Members	\$0.00	\$240.00	\$500.00	(\$260.00)
Fines	\$0.00	\$5,068.75	\$5,000.00	\$68.75
Raffle	\$105.00	\$450.00	\$500.00	(\$50.00)
Interest	\$0.00	\$35.31	\$250.00	(\$214.69)
Demotion Party	\$0.00	\$150.00	\$0.00	\$150.00
Retreat	\$0.00	\$3,705.50	\$3,800.00	(\$94.50)
Races	\$0.00	\$391.00	\$0.00	\$391.00
Tailgate	\$636.00	\$636.00	\$720.00	(\$84.00)
Offsite Lunches	\$0.00	\$1,738.00	\$750.00	\$988.00
Miscellaneous Income	\$30.00	\$706.83	\$250.00	\$456.83
Total Income	\$771.00	\$24,996.39	\$25,770.00	(\$773.61)

EXPENDITURE

R.I. Dues	\$24.00	\$3,038.85	\$2,900.00	(\$138.85)
District Dues	\$35.00	\$2,521.76	\$2,900.00	\$378.24
Supplies and Postage	\$0.00	\$195.76	\$750.00	\$554.24
Computer Expenses and Web Site	\$0.00	\$0.00	\$150.00	\$150.00
Officer Expense	\$0.00	\$295.40	\$500.00	\$204.60
Terminated Members	\$0.00	\$0.00	\$400.00	\$400.00
Miscellaneous Expense	\$212.32	\$552.80	\$750.00	\$197.20
Bank Charges	\$0.00	\$0.00	\$75.00	\$75.00
Lunch-Tornino's	\$1,451.50	\$1,451.50	\$750.00	(\$701.50)
Programs	\$91.58	\$91.58	\$250.00	\$158.42
Speakers	\$0.00	\$505.44	\$375.00	(\$130.44)
Demotion Party	\$0.00	\$75.00	\$0.00	(\$75.00)
Bulletin	\$0.00	\$0.00	\$125.00	\$125.00
Banners, Badges, Pins	\$0.00	\$787.06	\$250.00	(\$537.06)
Hospitality and Fellowship	\$0.00	\$0.00	\$1,625.00	\$1,625.00
Blue Book	\$0.00	\$0.00	\$375.00	\$375.00
Rotary Information	\$35.50	\$35.50	\$125.00	\$89.50
Membership	\$0.00	\$0.00	\$250.00	\$250.00
Duck Races	\$0.00	\$1,837.00	\$0.00	(\$1,837.00)
Retreat	\$0.00	\$4,381.23	\$6,000.00	\$1,618.77
Field Trips	\$366.78	\$366.78	\$500.00	\$133.22
Tailgate	\$0.00	\$0.00	\$800.00	\$800.00
Offsite Lunches	\$12.00	\$22.00	\$0.00	(\$22.00)
Camp Royal	\$200.00	\$200.00	\$0.00	(\$200.00)
Community Projects	\$0.00	\$0.00	\$625.00	\$625.00
Bullard Interact	\$0.00	\$0.00	\$125.00	\$125.00
SJM Interact	\$0.00	\$0.00	\$125.00	\$125.00
Youth Exchange	\$300.00	\$600.00	\$125.00	(\$475.00)
Paul Harris	\$0.00	\$0.00	\$625.00	\$625.00
Total Expenditure	\$2,728.68	\$16,957.66	\$21,475.00	\$4,517.34

Excess (Deficit)

(\$1,957.68) \$8,038.73 \$4,295.00 ~~(\$5,290.95)~~

*← Error
\$ 3,900 ± positive variance*

Fig Garden Rotary Computer Inventory List

(Items stored at Gymnastics Beat, Inc.)

Item	Name	Make	Description	Model#	Serial#
1	CPU	H.P.	Pavilion 6830	F2932A	KR10114050
2	CPU	eMachines, Inc.	Mini Tower	eTower 300 IX	QFK01E0011078
3	Monitor	Philips	17" VGA Monitor	107S21	47487226
4	Monitor	?(eMachine?)	VGA Monitor	X-554M	CZR990906658
5	Keyboard	eMachines, Inc.	Windows Keyboard	eKB-5000(A)	K01131336
6	Keyboard	H.P.	Internet/Windows Keyboard	5181-1596	BE05103183 rev. 1.2
7	Mouse	eMachines, Inc.	PS2 Mouse	M-8A851	LZB94624976
8	Mouse	H.P.	PS2 Mouse	5185-2413	LZB04857759
9	Printer	H.P.	LaserJet 1200 series	CX44A	CNC0037739
10	Hub	Linksys	10/100 8 Port workgroup hub	EFAAH08W ver 2	FGRHUB1
11	UPS	Belkin	350VA 190W Battery Backup	F6H 350-Set	2A025062059W4
12	UPS	Belkin	350VA 190W Battery Backup	F6H 350-Set	2A024652605W4
13	Surge Protector	Stantley	Power Bus/Surge Protector	STS162	FGRTS1
14	Surge Protector	Stantley	Power Bus/Surge Protector	STS162	FGRTS2

Revised: 11/23/2003



Eric K. Fogderude
President, 2002-2003

December 15, 2003

Rod Rimmer
✓ 33378 Puma
P.O. Box 527
Squaw Valley, CA 93675
Fax: 559-332-9301
e-mail: rodr@cckw.com

Joseph Wettstead
✓ 789 E. Wood Duck Circle
Fresno, CA 93720
Fax: 559-434-2572
e-mail: jwettstead@envoyww.com

Re: FGR equipment

Dear Rod and Joe:

Happy Holidays to you and your families.

I am happy to report that Joe Farmer has now prepared an itemized list with serial numbers and model descriptions of the Fig Garden Rotary computer auction related equipment which is in his custodial care. Per the Board of Directors suggestion, that equipment has now been relocated from Storyland-Playland to Sam Shima's business premises. The purpose for listing the equipment was to insure that future boards will know exactly what equipment is owned by FGR and where it is located. The purpose for moving the equipment to Sam's office, was to ensure the equipment was insured in case of theft or fire etc. I enclose a copy of that list which will be presented to the board at this Wednesday's meeting.

Could you please supplement this list and fax to me tomorrow with any additions FGR auction-computer equipment etc. which you are aware of and provide

Rod Rimmer
Joseph Wettstead
December 15, 2003
Page 2

the location of storage and whether the equipment stored is protected by insurance.

Last, to preserve the integrity of all future boards, it is requested that in the event that there is a desire to use any of FGR's equipment for non-FGR purposes, that the sitting board first be contacted for permission.

Thank you for being great stewards for FGR over the years.

Very truly yours,

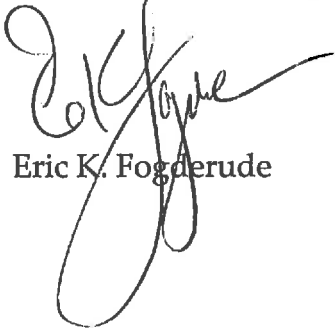

Eric K. Fogderude

ROTARY CLUB OF FIG GARDEN

FOUNDATION
BOARD OF DIRECTORS

*Regular Meeting -- 17 December 2003:

*Members Present:

Mike Graves
August Hioco
Matt Merzoian
Jeff Oliver
Steve Rontell
David Stepp
Steve Wilson

*Foundation Treasurer:

Jeff Garza

*Past President:

Eric Fogderude

*President-Elect:

Jamie Franklin

*President:

Dr. Rod Coburn

*Secretary:

*Treasurer:

Doug Cords

Scott Bristol

*Others Present:

Darryl Booth
Joe Farmer

The meeting was called to concurrent order with the Regular Board Meeting of the Rotary Club Of Fig Garden by President Rod Coburn in the Boardroom of the Stoughton Davidson Accountancy Corporation at 2530 West Shaw Lane, Suite 101, Fresno, California 93711 at 7:00 a.m.

*TREASURER'S REPORT: (Jeff Garza)

Jeff initially reviewed checks funded through the Union Bank account for last month, for Community Service Projects.

He reviewed the Endowment Account at UBS, Year To Date Income And Expenses, Compared To Budget, Portfolio Values, Cost Basis Versus Current Value and Community Service Donations Year To Date @ \$20,732.

Accounts:

*Unrestricted Funds:	\$113,408.00
*Permanent Funds:	<u>162,242.00</u>
*Totals:	<u>\$275,650.00</u>

It was MSC to approve the Treasurer's Report as presented.

*ADJOURNMENT: Concurrent With Regular Board Meeting, President Rod Coburn adjourned the meeting at 8:46 a.m.

*NEXT MEETING: 21 January 2004

Respectfully Submitted By Doug Cords, Ph.D., Foundation Secretary.

Fig Garden Rotary Endowment Account

Asset Allocation

US Large Co. Equity	\$ 43,780.32	26.98%
US Med/Sm Co. Equity	\$ 45,303.30	27.92%
Int'l Equity	\$ 20,442.40	12.60%
Int'l Fixed Income	\$ -	0.00%
US Fixed Income	\$ 51,371.21	31.66%
Cash / M.M	\$ 1,344.98	0.83%
	\$ 162,242.21	100.00%

Account Allocation

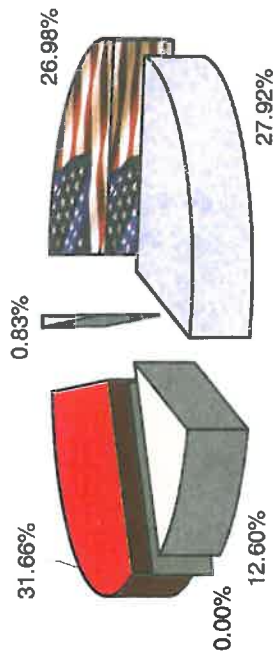

- US Large Co. Equity
- Int'l Equity
- US Fixed Income
- US Med/Sm Co. Equity
- Int'l Fixed Income
- Cash / M.M



Paul Sahota - Financial Advisor.

Investment Holdings

	Cost		Value 11/30/2003	Percent Gain / loss
	Basis			
<u>US Large Co. Equity:</u>				
Pimco Value Fund	\$ 18,092.69		\$ 23,694.97	30.96%
Growth Fund of America	\$ 18,562.25		\$ 20,085.35	8.21%
<u>US Med/Sm Co. Equity:</u>				
Columbia Acorn Fund	\$ 17,189.48		\$ 23,501.10	36.72%
Pimco Small Cap Value	\$ 18,097.42		\$ 21,802.20	20.47%
<u>Int'l Equity</u>				
Templeton Foreign	\$ 16,729.41		\$ 20,442.40	22.19%
<u>US & Int'l Fixed Income:</u>				
CD Discover Bank 2.5% due 11/08/04	\$ 12,000.00		\$ 12,072.60	0.61%
CD Key Bank & Trust 3.1% due 11/08/05	\$ 13,000.00		\$ 13,097.76	0.75%
CD Pan American Bank 3.65% due 10/30/06	\$ 12,930.84		\$ 13,344.37	3.20%
Treasury Bank 3.30% due 11/20/07	\$ 13,000.00		\$ 12,856.48	-1.10%
<u>Cash / Money Market:</u>				
Money Market	\$ 1,344.98		\$ 1,344.98	0.00%
TOTAL PORTFOLIO	\$ 140,947.07		\$ 162,242.21	15.11%
Cash & Cash Equivalents				
	\$ 1,344.98		\$ 1,344.98	
Total Securities	\$ 140,041.01		\$ 162,242.21	
Foundation Account Value				
	\$		\$ 90,877.42	

This is not an official Statement.
The information was obtained from sources deemed reliable, but we do not guarantee its accuracy.
Strictly for illustrative purposes only.

FGR Foundation-Net Worth

(Includes unrealized gains)

As of 11/30/2003

12/15/2003

Page 1

Account	9/30/2003 Balance	10/31/2003 Balance	11/30/2003 Balance
ASSETS			
Cash and Bank Accounts			
UBS Savings-Cash	90,763.91	90,842.02	90,877.42
Union Bank	20,869.25	25,021.25	21,521.25
WM Checking	8,881.86	1,009.63	1,009.63
TOTAL Cash and Bank Accounts	120,515.02	116,872.90	113,408.30
Investments			
UBS Permanent Fund	152,932.96	159,498.40	162,242.21
UBS Savings	0.00	0.00	0.00
TOTAL Investments	152,932.96	159,498.40	162,242.21
TOTAL ASSETS	273,447.98	276,371.30	275,650.51
LIABILITIES			
Other Liabilities			
Paul Harris Receipts Due RI	2,865.00	3,370.00	3,370.00
TOTAL Other Liabilities	2,865.00	3,370.00	3,370.00
TOTAL LIABILITIES	2,865.00	3,370.00	3,370.00
OVERALL TOTAL	270,582.98	273,001.30	272,280.51

Fig Garden Rotary Foundation
7/1/2003 Through 6/30/2004 Using My Budget

12/15/2003

Page 1

Category Description	7/1/2003 Actual	- Budget	6/30/2004 Difference
INCOME			
Auction 2004	0.00	75,000.00	-75,000.00
Clear Channel Donations	11,000.00	20,000.00	-9,000.00
Contributions from Club	0.00	10,000.00	-10,000.00
Earnings from Perm Fund	0.00	400.00	-400.00
Interest Inc	199.31	0.00	199.31
TOTAL INCOME	11,199.31	105,400.00	-94,200.69
EXPENSES			
Administrative Exps	0.00	25.00	25.00
Auction 2004 Expenses	0.00	19,500.00	19,500.00
Bank Charge	182.75	0.00	-182.75
Investment Expenses	630.12	0.00	-630.12
TOTAL Bank Charge	812.87	0.00	-812.87
Community Service	0.00	0.00	0.00
Community Service Donations 2003-2004	20,732.00	55,000.00	34,268.00
TOTAL Community Service	20,732.00	55,000.00	34,268.00
Contributions to PF FGRF	0.00	10,000.00	10,000.00
International Service	0.00	5,000.00	5,000.00
Misc Donations	0.00	500.00	500.00
Polio Plus	0.00	5,250.00	5,250.00
Vocational Service	0.00	5,000.00	5,000.00
Vocational Scholarships	0.00	5,000.00	5,000.00
TOTAL Vocational Service	0.00	10,000.00	10,000.00
TOTAL EXPENSES	21,544.87	105,275.00	83,730.13
OVERALL TOTAL	-10,345.56	125.00	-10,470.56

Portfolio Value

As of 11/30/2003

12/15/2003

Page 1

Security	Shares	Price	es	Cost Basis	Pre-Tax Gain	Balance
(No Type)						
-Cash-				92,222.40	0.00	92,222.40
TOTAL (No Type)				92,222.40	0.00	92,222.40
CD						
CD Discover Bnk 2.50% 11...	120.000	100.605		12,000.00	72.60	12,072.60
CD Key Bnk 3.10% 11/08/05	130.000	100.752		13,000.00	97.76	13,097.76
CD Pan Am Bnk 3.65% 10/...	130.000	102.649		12,930.84	413.53	13,344.37
Treasury Bank 3.30% 11/0...	130.000	98.896		13,000.00	-143.52	12,856.48
TOTAL CD				50,930.84	440.37	51,371.21
Mutual Fund						
Columbia Acorn	1,083.000	21.700		17,187.25	6,313.85	23,501.10
Growth Fund of America	853.606	23.530		18,562.25	1,523.10	20,085.35
Pimco Small Cap Value	895.000	24.360		18,095.89	3,706.31	21,802.20
Pimco Value Fund	1,613.000	14.690		18,090.05	5,604.92	23,694.97
Templeton Foreign	2,020.000	10.120		16,727.00	3,715.40	20,442.40
TOTAL Mutual Fund				88,662.44	20,863.58	109,526.02
TOTAL Investments				231,815.68	21,303.95	253,119.63

FGRF-Community Service Donations YTD

1/1/2003 Through 12/15/2003

12/15/2003

Page 1

Cat/Sub	Date	Account	Num	Description	Memo	Clr	Amount
EXPENSES							
Community Service							
Community Servi...							
	7/18/2003	WM Checki...	628	Fresno Survivors of Suic...	Board Mtg 7/16/03	R	-1,222.00
	7/18/2003	WM Checki...	629	Salvation Army	Board Mtg 7/16/03	R	-550.00
	7/18/2003	WM Checki...	630	Sequoia Council of Boy ...	Board Mtg 7/16/03	R	-1,000.00
	7/18/2003	WM Checki...	631	Criminal Justice Advoca...	Board Mtg 7/16/03	R	-1,060.00
	8/20/2003	WM Checki...	632	Housing League of Fres...	Operation School...	R	-700.00
	9/17/2003	WM Checki...	634	Big Brothers/Big Sisters	HS Big Mentoring...	R	-6,000.00
	9/17/2003	WM Checki...	635	Trauma Intervention Pro...	BofD Mtg 9/17/03	R	-2,500.00
	10/24/2...	Union Bank	1001	Crime Stoppers		R	-1,200.00
	10/24/2...	Union Bank	1002	Fresno Co. Office of Ed...	Raymacher School	R	-3,000.00
	11/4/2003	Union Bank	1003	Fresno Police Chiefs Fo...	Bomb Dog		-500.00
	11/4/2003	Union Bank	1004	Al Trujillo	Christmas Baskets		-2,000.00
	11/23/2...	Union Bank	1005	Wishon Elementary Sch...	Literacy Center		-500.00
	11/23/2...	Union Bank	1006	Candlelighters	Food Vouchers		-500.00
TOTAL Communi...							-20,732.00
TOTAL Community ...							-20,732.00
TOTAL EXPENSES							-20,732.00
OVERALL TOTAL							-20,732.00